

Ketchikan BEACH Monitoring

July – September 2017



This Final Report was prepared by the Alaska Department of Environmental Conservation.

This project has been funded wholly or in part by the United States EPA under assistance agreement number (BEACH-CU-00J71801) to the Department of Environmental Conservation through the Alaska Clean Water Actions (ACWA) program. The contents of this document do not necessarily reflect the views and policies of the EPA, nor does the EPA endorse trade names or recommend the use of commercial product mentioned in this document.

Report cover photo was taken at Rotary Beach Park.

CONTENTS

Summary.....	5
1. About Alaska’s BEACH Program.....	5
2. Ketchikan BEACH Monitoring Locations	6
3. Methods	23
4. Results.....	26
4.1 Fecal Coliform.....	29
4.2 Enterococci.....	30
4.3 MST.....	30
5. Results Summary	32
5.1 Sanitary Surveys.....	32
5.1.1 Discussion.....	32
5.1.2 Public Outreach	33
6. Conclusions.....	33
7. References.....	34

LIST OF TABLES

Table 1. Monitoring Locations and Site Descriptions.....	7
Table 2. Monitoring Site Selection Rationale.....	8
Table 3. Alaska water quality criteria for bacteria in marine waters	25
Table 4. 2017 Ketchikan BEACH Monitoring Analytical Data Results.....	26
Table 5. Summary of Fecal Coliform Bacteria results.....	29
Table 6. Summary of Enterococci results	30
Table 7. Bacteria results comparison to MST results	31

LIST OF FIGURES

Figure 1. Ketchikan BEACH Monitoring Locations	10
Figure 2. Ketchikan BEACH Monitoring Locations – Northern sites	11
Figure 3. Ketchikan BEACH Monitoring Locations – Southern sites.....	12
Figure 4. Ketchikan BEACH Monitoring Locations – Knudson Cove and Beacon Hill	13
Figure 5. Ketchikan BEACH Monitoring Locations – Knudson Cove, Beacon Hill and South Point Higgins	14
Figure 6. Ketchikan BEACH Monitoring Locations – South Point Higgins and Shull	15

Figure 7. Ketchikan BEACH Monitoring Locations – Sunset and South Refuge Cove 16

Figure 8. Ketchikan BEACH Monitoring Locations – Thomas Basin..... 17

Figure 9. Ketchikan BEACH Monitoring Locations – Seaport and Rotary 18

Figure 10. Ketchikan BEACH Monitoring Locations – Ketchikan Airport, Ferry Dock, Cruise Ship Dock
and Anchor Area..... 19

Figure 11. Ketchikan BEACH Monitoring Northern Locations, Anadromous Streams and Lakes 20

Figure 12. Ketchikan BEACH Monitoring Central Location, Anadromous Streams and Lakes..... 21

Figure 13. Ketchikan BEACH Monitoring Southern Locations, Anadromous Streams and Lakes..... 22

This page intentionally left blank

Summary

The Alaska BEACH program was initiated along the Ketchikan coastline to monitor fecal waste contamination during the 2017 recreation season. Marine water samples were collected from July through September to evaluate potential health risks indicated by fecal coliform and enterococci bacteria, and to notify the public when levels exceeded state standards.

The 2017 analytical tests for fecal coliform bacteria revealed that all nine of the monitoring sites failed to meet the Alaska water quality standard (WQS) single sample criteria for seafood processing, aquaculture and harvesting for consumption uses. Seven of the nine sites failed to meet the Alaska WQS geometric mean criterion for harvesting for consumption use and five of nine also failed the geometric mean criteria for seafood processing and aquaculture uses. For enterococci tests, eight of the nine monitoring sites failed to meet the Alaska WQS statistical threshold value (STV) criterion, and all nine of the sites failed to meet the Alaska WQS geometric mean criterion for the recreation use.

In addition to bacteria testing, the Alaska Department of Environmental Conservation (DEC) began a source investigation of the pollution. Microbial source testing for bacteria genetic identification was also conducted. The human host marker was detected at all nine monitoring locations. One high use recreational beach also had dog and gull host markers detected, and a boat harbor known for youth recreational swimming/jumping had a gull host marker detected, as well as the human marker.

Numerous potential bacteria sources are present along the Ketchikan coast, including: private and/or public sewer treatment system outfall(s), public treatment system emergency bypasses, sewer line breaks, individual septic tanks, wildlife, pet feces, boats in harbor and launch areas, cruise ships, private watercraft and ferries¹.

Further bacteria and microbial source testing is planned for the 2018 Ketchikan BEACH Monitoring Program which will help determine bacteria sources, and support the development of solutions and implementation of bacteria source reduction in these areas.

1. About Alaska's Beach Program

In response to increased occurrences of water-borne illnesses U.S. Congress passed the Beaches Environmental Assessment and Coastal Health (BEACH) Act in 2002. The U.S. Environmental Protection Agency (EPA) administers grant funds to states, tribes and territories under the Act to establish monitoring and public notification programs. The BEACH program has established national marine water quality monitoring and reporting standards for fecal waste contamination and notifies the public when levels exceed state standards.

Congress passed the BEACH Act because pathogens in recreational waters can be naturally occurring, or they can be introduced through contamination events with the feces of humans and other warm-blooded

¹ Although the cruise ship and ferries are a potential source, based on the analytical results from the permit-required marine water sampling for commercial passenger vessels during the 2017 Ketchikan BEACH monitoring project (July 18-September 13), there were no exceedances of the Alaska WQS for fecal coliform bacteria from large cruise ships discharging while stationary (traveling under 6 knots) within Southeast Alaska, including near Ketchikan. Small cruise ships and ferries operate under Best Management Practices, they typically hold wastewater when stationary. Therefore, cruise ships and ferries are an unlikely source of bacteria pollution during the 2017 investigation period.

animals. Commonly documented health issues from swimming in contaminated recreational waters include gastrointestinal illness, respiratory illnesses, skin rashes, and ear, eye, and wound infections. People who get an illness from swimming in contaminated water do not always associate their illness with swimming because the onset of the illness is delayed. For example, viral gastrointestinal illness is often mild, short-lived, and self-limiting, and symptoms usually take up to 24 hours to appear. Outbreaks of disease are usually documented when many people seek medical assistance because of a similar illness or the severity of the illness. However, people with mild illness often do not seek medical assistance. Therefore, disease outbreaks are often inconsistently recognized and the outbreak information in the literature is likely underestimated².

In Alaska, the Alaska DEC's Division of Water uses EPA grant funds for the Alaska BEACH program. Alaska's BEACH program provides funds to municipalities, watershed organizations, and tribal groups to conduct water quality monitoring on high-priority public beaches. BEACH programs have been set up in 15 Alaskan communities including Ketchikan. The Ketchikan BEACH program was developed in collaboration with the Ketchikan Indian Association (KIC). In 2017, KIC performed the monitoring activities at the nine beaches in Ketchikan.

Two groups of bacteria, fecal coliform and enterococci, are measured as indicators of fecal waste contamination in marine waters. These bacteria are found in both human and animal feces. Alaska's criteria for bacteria is discussed in Section 4 Methods.

2. Ketchikan BEACH Monitoring Locations

The monitoring locations are situated along the coastal recreational areas within several watersheds. The surrounding and upgradient area uses include boat harbors, residential/commercial/industrial, state recreational sites, neighborhood/local beaches and shellfish gathering.

The nine beaches monitored are: Rotary Beach Park, Seaport Beach, Thomas Basin, south of South Refuge Cove State Recreation Site, beach off Sunset Drive, beach at Shull Road, South Point Higgins Beach, Beacon Hill, and Knudson Cove (see Figures 1-3). The site selection was based on information collected from the Alaska Beach Survey, as well as potential bacteria sources. The survey assessed the types of recreational activities and the level of use during the recreational season for beaches around Ketchikan.

Table 1 provides a site description for each monitoring location. Table 2 describes the rationale for site selection.

² EPA National Beach Guidance and Required Performance Criteria for Grants, 2014 Edition (EPA-823-B-14-001).

Table 1. Monitoring Locations and Site Descriptions

Site ID	Latitude	Longitude	Site description
Knudson Cove	55° 28' 19.47" N	131° 47' 46.76" W	Beach and small boat harbor in Knudson Cove in southern end of Clover Pass, approx. 10 miles north of downtown.
Beacon Hill	55° 28' 20.21" N	131° 49' 22.98" W	South of Clover Passage, approx. 9.4 miles north of downtown.
South Point Higgins Beach	55° 26' 55.12" N	131° 49' 52.90" W	South of South Point Higgins Beach, approx. 8.3 miles north of downtown.
Beach at Shull Road	55° 26' 7.57" N	131° 47' 54.62" W	South of Whipple Creek mouth, approx. 6.7 miles north of downtown.
Beach at Sunset Drive	55° 24' 45.40" N	131° 45' 54.19" W	On Sunset Peninsula approx. 4.7 miles north of downtown. South of Mud Bay.
South Refuge Cove State Recreation Site	55° 24' 26.62" N	131° 45' 19.77" W	South of state recreation site approx. 4 north miles of downtown.
Thomas Basin	55° 20' 28.49" N	131° 38' 30.45" W	Small boat harbor at mouth of Ketchikan Creek, approx. 2.5 miles south of downtown.
Seaport Beach	55° 18' 52.63" N	131° 35' 35.68" W	Local shellfish gathering beach approx. 5 miles south of downtown. Commercial area in Saxman.
Rotary Park Beach (aka Bugges Beach)	55° 18' 31.50" N	131° 34' 39.34" W	Highly used recreation beach approx. 6 miles south of downtown. Concrete enclosure at outlet, marine water flows over enclosure.

Table 2. Monitoring Site Selection Rationale

Site ID	Potential point and nonpoint sources									
	Individual septic tanks	Private sewer treatment system outfall(s)	Wildlife Pet feces	Private watercraft	Cruise ships, Ferries	Public sewer treatment system outfall(s)	Sewer line breaks	Public treatment system emergency bypasses	Boats at boat launches and in harbor areas	
Knudson Cove	✓	✓	✓	✓					✓	
Beacon Hill	✓	✓	✓	✓						
South Point Higgins	✓	✓	✓	✓	✓			✓		
Shall	✓	✓	✓	✓	✓			✓		
Sunset	✓	✓	✓	✓	✓			✓		
South Refuge Cove	✓	✓	✓	✓	✓			✓		
Thomas Basin	✓	✓	✓	✓	✓	✓	✓	✓	✓	
Seaport	✓	✓	✓	✓	✓	✓	✓	✓	✓	
Rotary	✓	✓	✓	✓	✓	✓	✓			

Figures 1-3 show the overall view of the Ketchikan BEACH monitoring locations. Figures 4-9 show detailed views of the monitoring locations. Figure 10 shows the Cruise Ship docking and anchor area (outlined in blue), and the ferry docking area (outlined in blue), and the airport. Figures 11-12 show the monitoring locations in relation to anadromous streams and lakes.

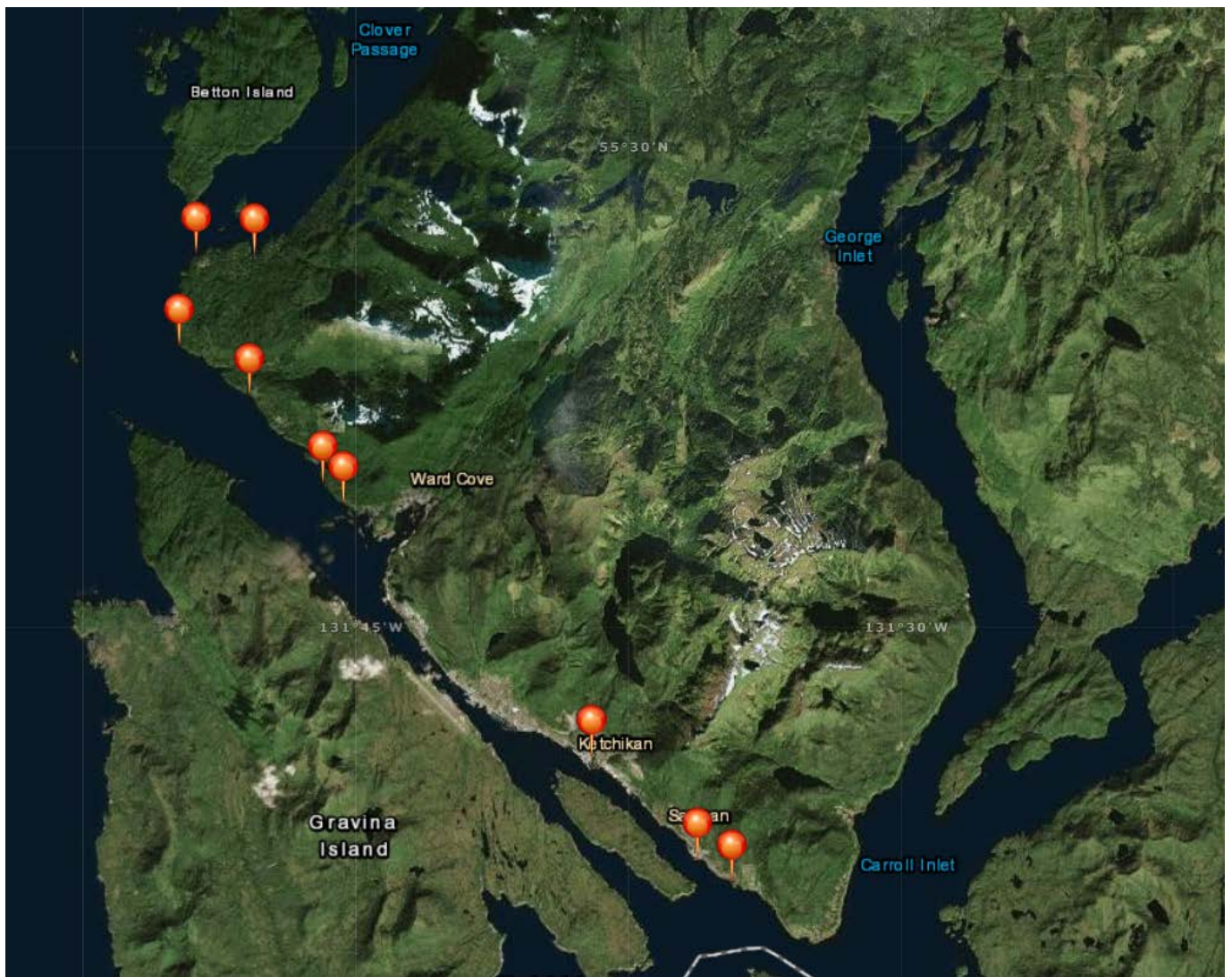

Figure 1. Ketchikan BEACH Monitoring Locations



Figure 2. Ketchikan BEACH Monitoring Locations – Northern sites



Figure 3. Ketchikan BEACH Monitoring Locations – Southern sites

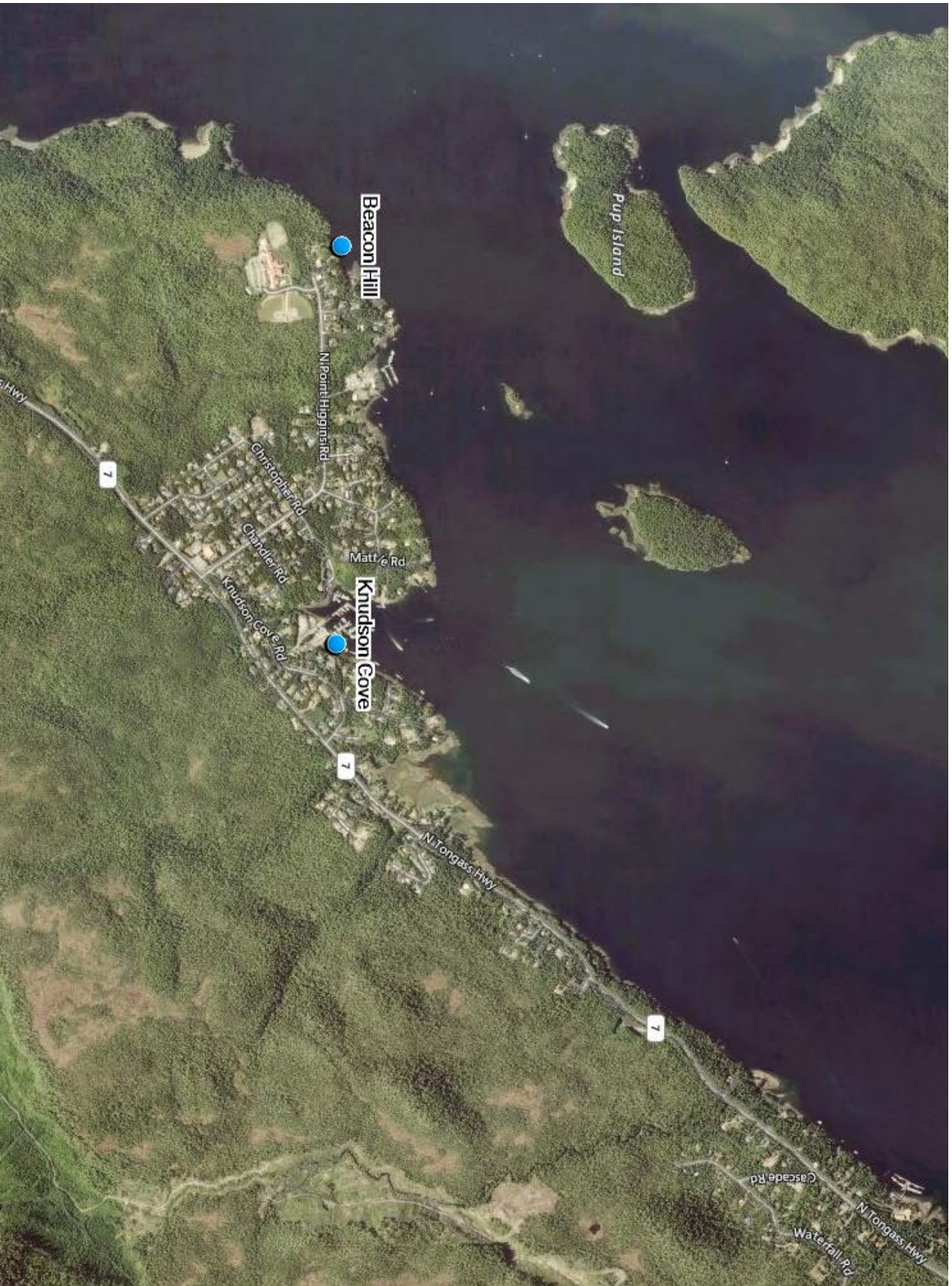

Figure 4. Ketchikan BEACH Monitoring Locations – Knudson Cove and Beacon Hill



Figure 5. Ketchikan BEACH Monitoring Locations – Knudson Cove, Beacon Hill and South Point Higgins

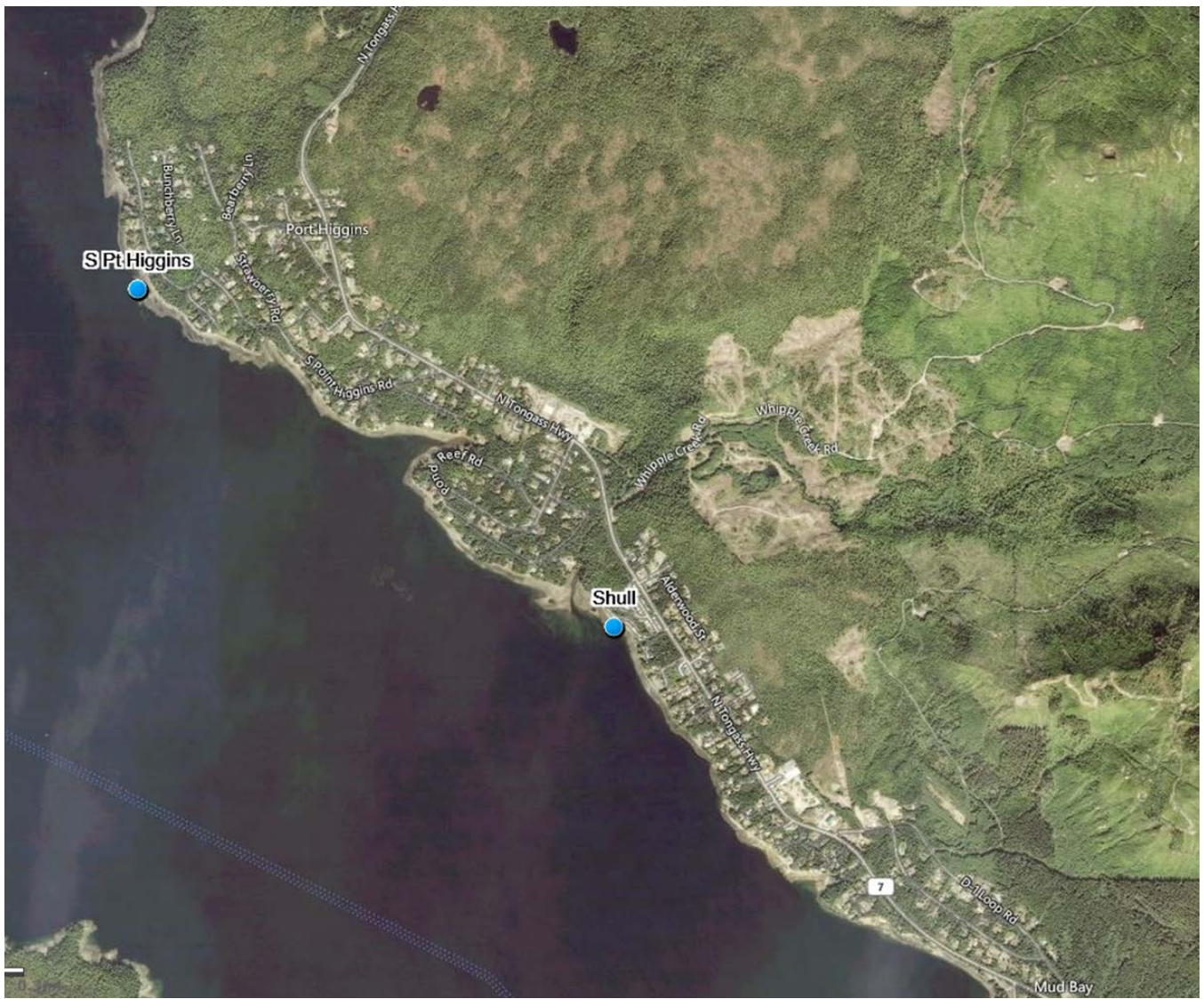

Figure 6. Ketchikan BEACH Monitoring Locations – South Point Higgins and Shull

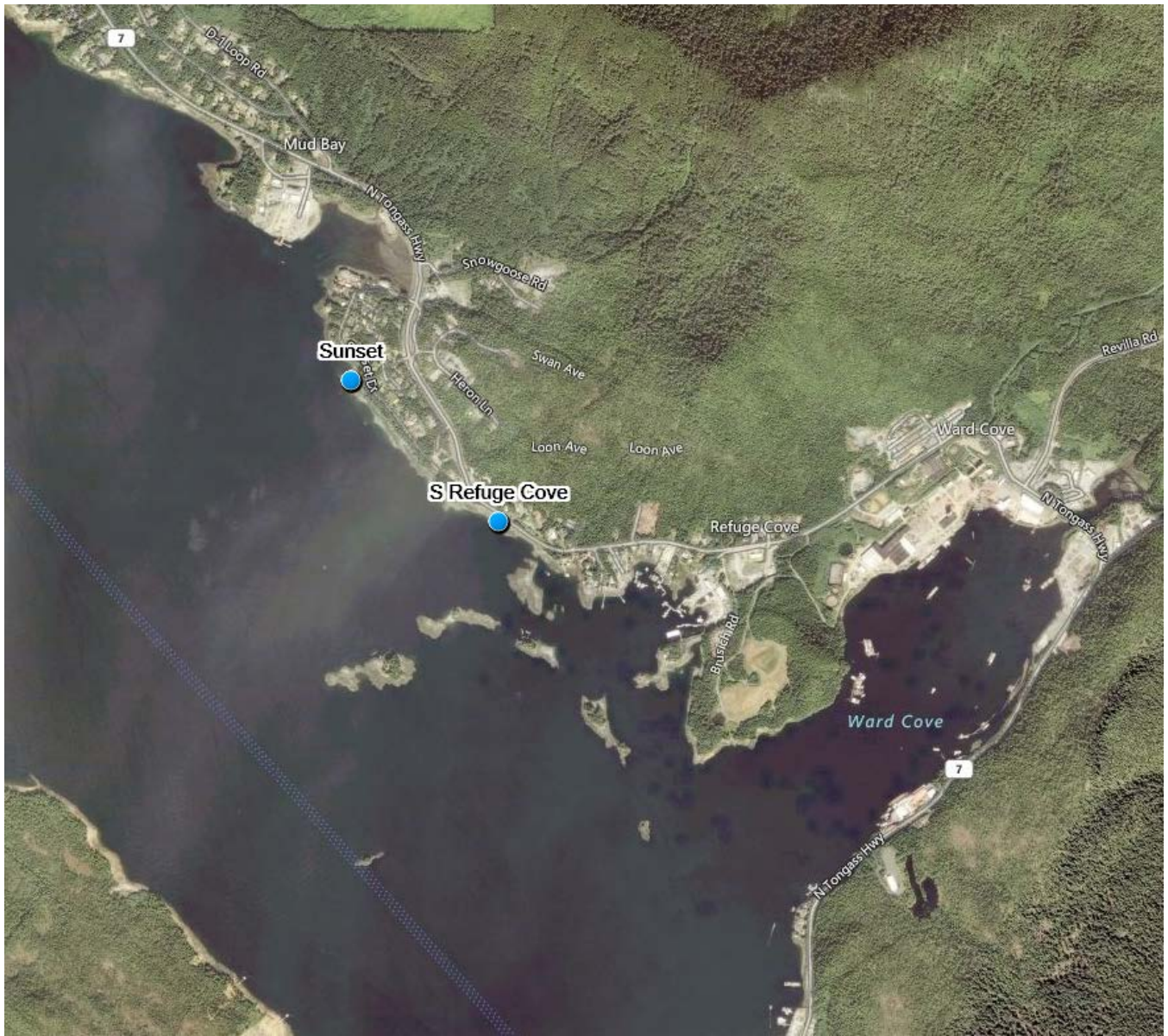

Figure 7. Ketchikan BEACH Monitoring Locations – Sunset and South Refuge Cove

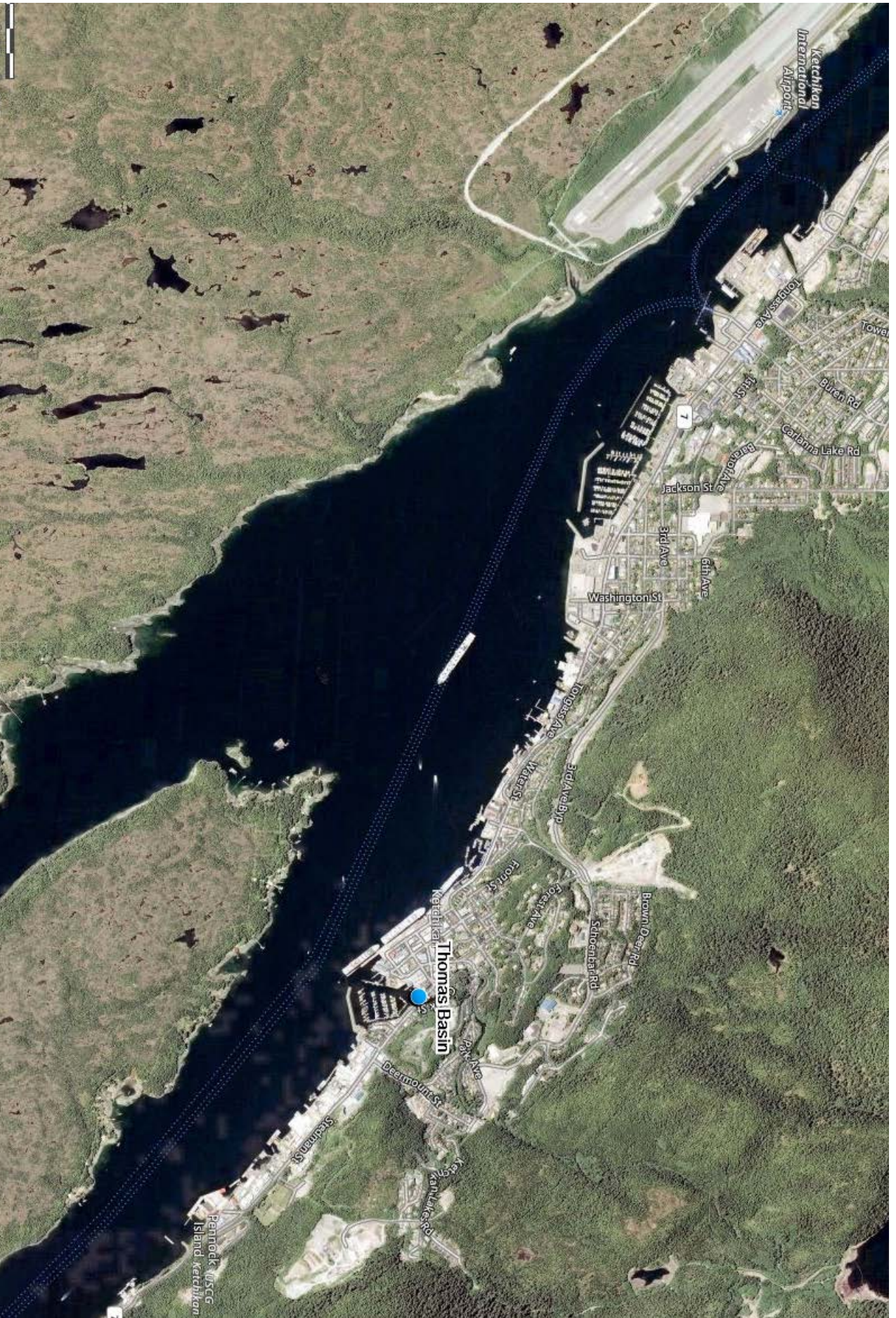

Figure 8. Ketchikan BEACH Monitoring Locations – Thomas Basin

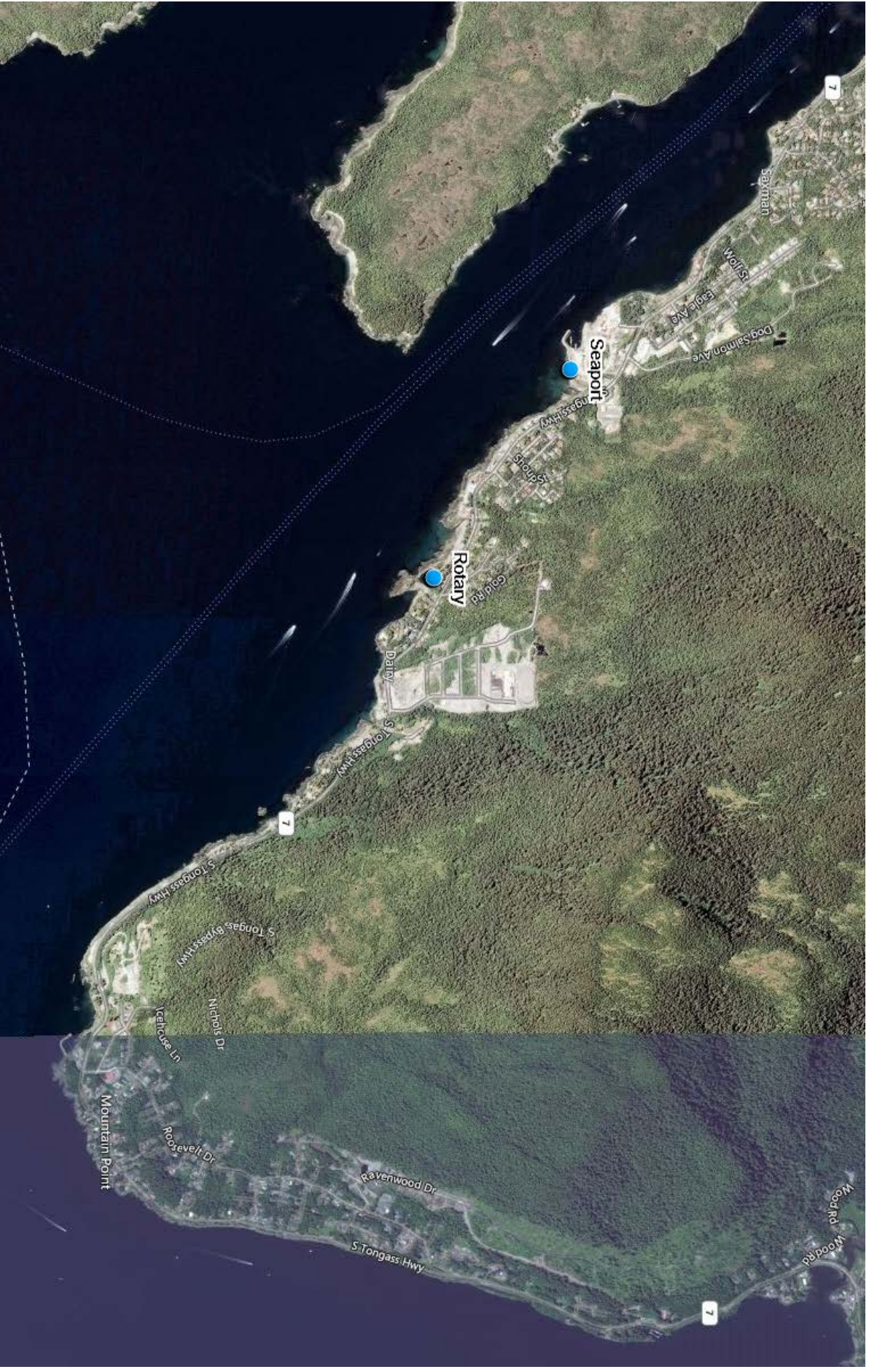

Figure 9. Ketchikan BEACH Monitoring Locations – Seaport and Rotary

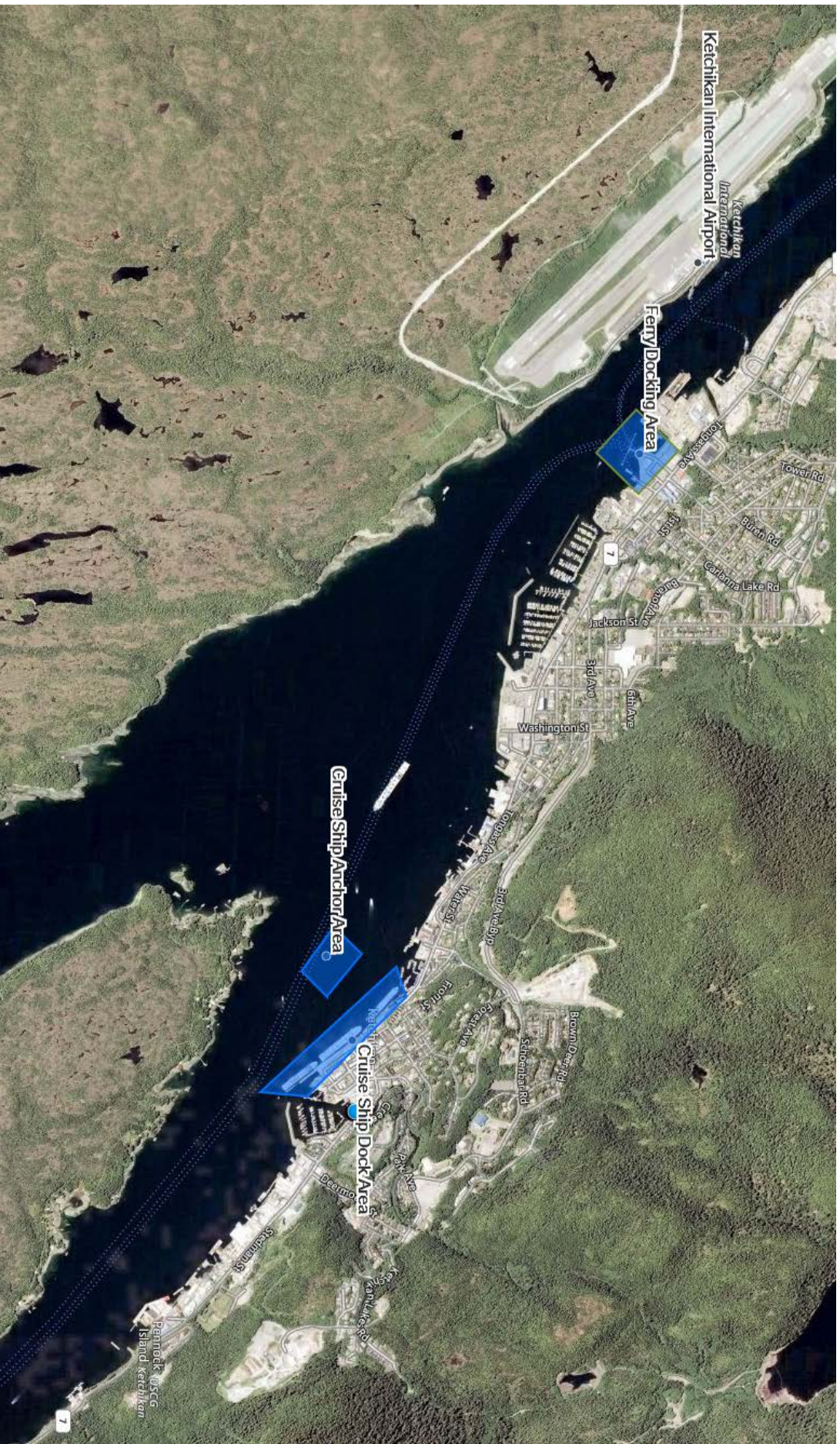

Figure 10. Ketchikan BEACH Monitoring Locations – Ketchikan Airport, Ferry Dock, Cruise Ship Dock and Anchor Area

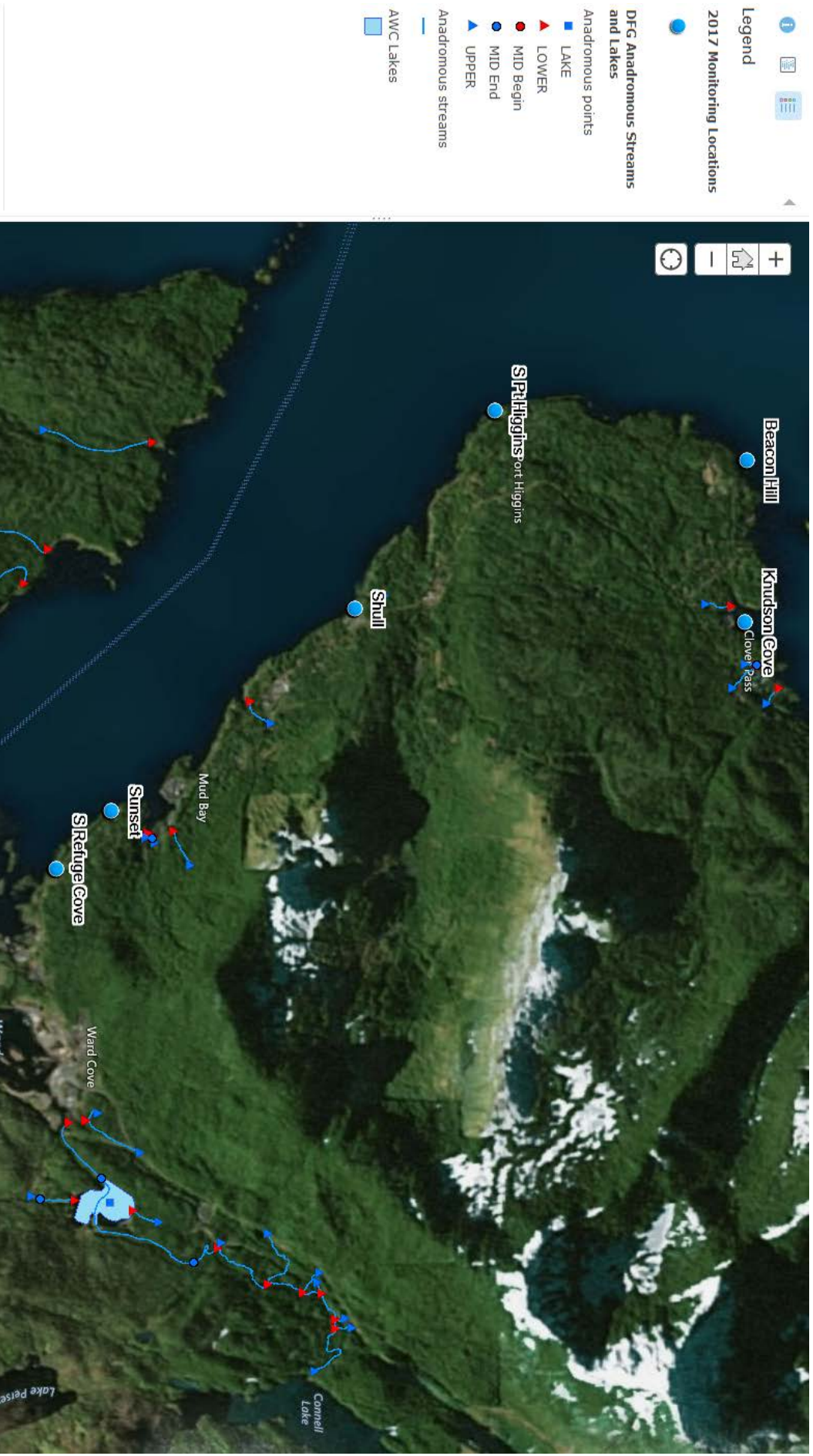

Figure 11. Ketchikan BEACH Monitoring Northern Locations, Anadromous Streams and Lakes



Figure 12. Ketchikan BEACH Monitoring Central Location, Anadromous Streams and Lakes

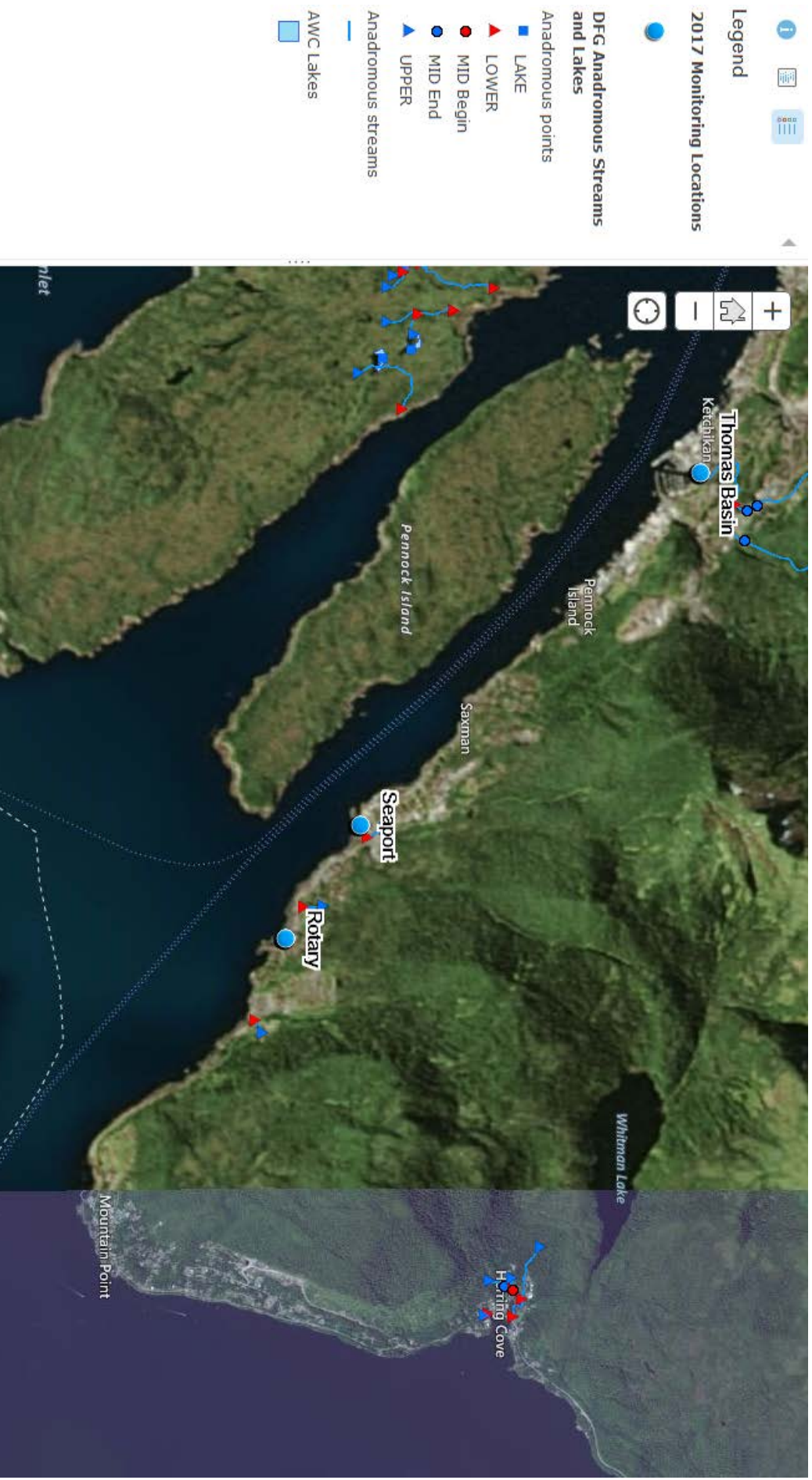

Figure 13. Ketchikan BEACH Monitoring Southern Locations, Anadromous Streams and Lakes

3. Methods

Samples were collected for the Ketchikan BEACH monitoring project at nine different sample locations (see Figures 1-13) along the coast of Ketchikan. Samples were generally collected once per week from July 18 through September 13, 2017. Sanitary surveys were also conducted, and are attached as Appendix A. The chain of custody and laboratory analytical reports for samples are attached as Appendix B. Site photographs are attached as Appendix C.

Each sample was collected using the grab method with a 120 ml bottle preserved with sodium thiosulfate. A field replicate for both analytical parameters (fecal coliform and enterococci) was collected from one monitoring location per week on a rotating schedule so that replicates were collected from each monitoring location³. Temperature blanks accompanied all coolers to document that samples remained within acceptable limits.

All bacteria samples were collected by KIC staff⁴ following Standard Operating Procedures as described in the July 2017 *Ketchikan BEACH Water Quality Monitoring and Pathogen Detection Quality Assurance Project Plan* (QAPP) and the July 2017 *Ketchikan BEACH Monitoring Handbook* (attached as Appendix D). Trained staff collected water samples wearing chest waders and shoulder length gloves. After wading to a depth of approximately three feet, water samples were collected about one foot below the surface of the water to avoid collecting water surface matter. During sampling at each location, the Marine Beach Sanitary Survey ‘app’ was completed. The ‘app’ stores information on water recreation and beach usage activities, wildlife, weather, water and air temperature, tidal conditions, and potential sources of pollution. Site-specific survey summary tables are attached as Appendix A.

R&M Engineering-Ketchikan, Inc. (R&M), a DEC-approved water quality laboratory⁵ in Ketchikan, performed analyses of bacterial colonies present in the samples. R&M provided all sampling bottles, materials, and coolers. After sample collection, the sample bottles were stored in a cooler between 1 and 10 degrees Celsius and were returned to the laboratory within 6 hours of collection. Laboratory staff checked each temperature blank upon receipt. All sample temperatures were within acceptable limits. R&M submitted results to KIC and DEC by email within 72 hours of receiving the samples.

Samples were also collected for Microbial Source Tracking (MST)⁶ analysis; these samples were selected based on the positive fecal coliform and enterococci results. On August 8 and 9, 2017, the MST samples were collected at the same location, date and time of the fecal coliform and enterococci samples. MST samples were collected into unpreserved laboratory-supplied 500 ml sterile polycarbonate Corning bottles. A field replicate was collected for quality assurance purposes.

Source Molecular, Inc., an EPA accepted MST and pathogen detection laboratory in Miami Florida, performed analyses using the quantitative polymerase chain reaction (qPCR) method to determine the

³ QA duplicate samples were named Mtn. Point and Settlers for QA purposes only; there are no samples collected from the Mtn. Point or Settlers locations.

⁴ July 18 samples were collected by DEC staff during a site selection and training visit.

⁵ R&M laboratory is certified to perform microbiology analyses of drinking water.

⁶ MST is a set of methods used to determine the host (different animals or human).

host(s) (human or animals/wildlife) present in the samples. MST samples were packed in the cooler with gel ice and temperature blank, and were shipped Fed Ex standard overnight to Source Molecular immediately after the project sample collection. Source Molecular laboratory staff checked each temperature blank upon receipt. All sample temperatures were within acceptable limits.

Data was reviewed for quality control and assurance by the DEC Quality Assurance Officer and the DEC Alaska BEACH Project Manager. The project data was subsequently uploaded to the state Ambient Water Quality Monitoring System (AQWMS) database, and transmitted to the EPA BEACH program using the Water Quality eXchange (WQX) and maintained in the EPA's STOrage and RETrieval (STORET) data warehouse.

Applicable Alaska WQS for fecal coliform and enterococci in marine waters address the protection of designated uses for water supply (including aquaculture, seafood processing and industrial uses), water recreation, and harvesting for consumption of raw mollusks or other raw aquatic life. The BEACH program focuses on the water recreation designated use using enterococci as an indicator for bacteria in the marine water. Data was compared to the contact recreation guidelines of "In a 30-day period, the geometric mean of samples may not exceed 35 enterococci CFU/100 ml, and not more than 10% of the samples may exceed a STV of 130 enterococci CFU/100 ml" (18 AAC 70 (14)(B)(i)).

Data was also compared to all applicable Alaska water quality criteria for fecal coliform bacteria. The most stringent of the criteria for fecal coliform bacteria protecting harvesting for consumption of raw mollusks or other raw aquatic life. This harvesting use criteria states that "the geometric mean of samples may not exceed 14 fecal coliform/100 ml, and not more than 10% of the samples may exceed 31 CFU per 100 ml for a membrane filtration test" (18 AAC 70 (14)(D)). These applicable criteria are show in Table 3, and highlighted in blue.

Table 3. Alaska water quality criteria for bacteria in marine waters⁷

Designated use	Description of criteria
(14) Bacteria, For Marine Water Uses	
(A) Water Supply	
<i>(i) aquaculture</i>	For products normally cooked, the geometric mean of samples taken in a 30-day period may not exceed 200 fecal coliform/100 ml, and not more than 10% of the samples may exceed 400 fecal coliform/100 ml. For products not normally cooked, the geometric mean of samples taken in a 30-day period may not exceed 20 fecal coliform/100 ml, and not more than 10% of the samples may exceed 40 fecal coliform/100 ml.
<i>(ii) seafood processing</i>	In a 30-day period, the geometric mean of samples may not exceed 20 fecal coliform/100 ml, and not more than 10% of the samples may exceed 40 fecal coliform/100 ml.
<i>(iii) industrial</i>	Where worker contact is present, the geometric mean of samples taken in a 30-day period may not exceed 200 fecal coliform/100 ml, and not more than 10% of the samples may exceed 400 fecal coliform/100 ml.
(B) Water Recreation	
<i>(i) contact recreation</i>	In a 30-day period, the geometric mean of samples may not exceed 35 enterococci CFU/100 ml, and not more than 10% of the samples may exceed a statistical threshold value (STV) of 130 enterococci CFU/100 ml.
(C) Growth and Propagation of Fish, Shellfish, Other Aquatic Life, and Wildlife	Not applicable.
(D) Harvesting for Consumption of Raw Mollusks or Other Raw Aquatic Life	The geometric mean of samples may not exceed 14 fecal coliform/100 ml; and not more than 10% of the samples may exceed; - 43 MPN per 100 ml for a five-tube decimal dilution test; - 49 MPN per 100 ml for a three-tube decimal dilution test; - 28 MPN per 100 ml for a twelve-tube single dilution test; - 31 CFU per 100 ml for a membrane filtration test (see note 14). ⁸

⁷ Source: 18 AAC 70.020 Water Quality Standards, amended as of February 5, 2017.

⁸ Note 14. When fecal coliform are monitored in waters designated as state approved shellfish harvesting and growing waters, these waters are also subject to 18 AAC 34.010(19).

4. Results

Table 4 is a summary table of testing results. Chain of custody and laboratory analytical reports are attached in Appendix B. Graphs showing each individual monitoring location results are attached in Appendix E.

Table 4. 2017 Ketchikan BEACH Monitoring Analytical Data Results – next page

**2017 Ketchikan BEACH Monitoring
Analytical Data Results**

Sample Date	Tides	Knudson Cove			Beacon Hill			S Pt/Higgins			Shull			Sunset			S Refuge Cove			Thomas Basin			Seaport			Rotary		
		FC	Enter	MST	FC	Enter	MST	FC	Enter	MST	FC	Enter	MST	FC	Enter	MST	FC	Enter	MST	FC	Enter	MST	FC	Enter	MST	FC	Enter	MST
Aug 8/9	Ebb	98	1986.3	1.38E+03 Human	11	579.4	1.60E+02 Human	7 (3)	1119.9 (980.4)	DNQ Human	4	75.9	1.68E+02 Human	142	248.1	DNQ Human	8 (15)	1299.7 (157.8)	1.53E+02 Human	42	86.2	1.38E+02 Human	21	204.6	1.18E+03 Human	27	980.4	DNQ Human
Jul 31/Aug 1	Ebb	167	15.6		6	26.6		<1	13.1		6	20.6		41 (8)	34.1 (46.4)		7	26.6		7	3.0		4 (7)	3.1 (26.6)		9	47.4	
Jul 26/27	Ebb	9	12.2		6	19.3		16 (2)	(23.8)		12	27.5		13	10.9		8	12.1		14	>2419.6		3	7.3		99 (137)	980.4 (579.4)	
Jul 24/25	Flood	5	3.0		2	<1		8	4.1		167 (68)	124.6 (81.3)		16	8.5		11 (7)	6.1 (5.2)		9	4.1		7	2.0		68	45.7	
Jul 18/19	Ebb	16	5.1		5	1.0		<1	1.0		8	6.2		<1	4.1 (5.2)		11	2.0		5	2.0		3 (<1)	3 (3.1)		6	3.0	
Aug 14/15	Flood /Ebb	6 (9)	(26.3)		22	16.6		161	82.3		27	50.4		15	22.5		6	21.3		36	156.5		37	21.1		21	69.7	
Aug 22/23	Flood	>200	488.4		58	101.7		37	46.2		33	28.1		51 (29)	33.7 (47.4)		69 (32)	81.6 (57.8)		CG (250)	137.4		CG (250)	250.0		>200	1119.9	
Aug 29/	Ebb/ Flood	2	1.0		18	7.2		5	24.3		16	3.0		3 (2)	<1 (8.5)		7	13.0		<1	14.5		41 (250)	135.4		9	69.3	
Sep 13/	Flood	12	14.5		8	9.7		2	9.5		9	8.4		17	9.5		4	13.5		13	70.3		21 (22)	12 (21.3)		6	26.2	
Rolling geomean																												
Jul 18-Aug 16 30-day (6)		22	23		7	12		6	22		15	34		14	22		9	22		14	30		9	13		26	112	
Jul 24-Aug 22 30-day (6)		33	50		10	25		12	42		19	44		31	32		13	41		26	62		17	27		46	300	
Jul 26-Aug 24 30-day (5)		48	87		14	55		13	67		12	36		36	42		13	59		33	106		21	46		43	437	
Jul 31-Aug 29 30-day (5)		36	53		17	45		10	67		13	23		27	40		12	60		17	38		35	83		25	257	
Aug 8-Sep 6 30-day (4)		NA	NA		NA	NA		NA	NA		NA	NA		NA	NA		NA	NA		NA	NA		NA	NA		NA	NA	
Aug 14-Sep 12 30-day (3)		NA	NA		NA	NA		NA	NA		NA	NA		NA	NA		NA	NA		NA	NA		NA	NA		NA	NA	
Aug 22-Sep 20 30-day (3)		NA	NA		NA	NA		NA	NA		NA	NA		NA	NA		NA	NA		NA	NA		NA	NA		NA	NA	
WQ Standards																												
Recreation - enterococcus			130 STV	35 geomean																								
Harvesting (most stringent) - fecal coliform			31 single	14 geomean																								

Tides focus is on either side of low tide, using ebb and flow stages.
 Rolling geomean calculation uses value of 0.5 for non-detect results (<1); highest result from duplicate and regular samples; and shows the number of samples collected during the 30-day period in parentheses.
 () in results indicates duplicate sample

CG - Confluent Growth
 DNQ - detected not quantified
 Fecal Coliform results shown in cfu/100 ml
 Enterococcus results shown in MPN/100 ml

This page intentionally left blank.

4.1 Fecal Coliform

Presence of fecal coliform bacteria colonies ranged from non-detect (<1 coliform forming units (CFU)/100 ml) to confluent growth (estimated as >250 CFU/100 ml) at the Ketchikan BEACH monitoring sites. All nine of the monitoring sites failed to meet the Alaska water quality standard single sample for fecal coliform bacteria of “not more than 10% of the samples may exceed 31 CFU per 100 ml for a membrane filtration test.” Seven of the nine monitoring sites failed to meet the Alaska WQS geometric mean for fecal coliform bacteria of the “geometric mean of samples may not exceed 14 fecal coliform/100 ml.” In addition, five of the nine sites also exceeded the aquaculture and seafood processing criteria stating “in a 30-day period, the geometric mean of samples may not exceed 20 fecal coliform/100 ml. South Point Higgins Beach and South Refuge Cove State Recreation Site are the locations that met the geometric mean for fecal coliform. Table 5 shows the summary of fecal coliform bacteria results.⁹

Table 5. Summary of Fecal Coliform Bacteria results

Fecal coliform bacteria results (CFU/100 mL)					
Monitoring locations	Total # of samples	Total # of samples exceeding 31 CFU/100 mL	Maximum sample value	Total # of samples exceeding 14 CFU/100 mL geometric mean	Maximum geometric mean value
Knudson Cove	9	3	>200 ¹⁰	4	48
Beacon Hill	9	1	58	3	17
South Point Higgins Beach	9	2	161	0	13
Beach at Shull Road	9	2	167	2	19
Beach at Sunset Drive	9	3	142	4	36
South Refuge Cove State Recreation Site	9	1	69	0	13
Thomas Basin	9	3	CG¹¹ (estimated as 250)	4	33
Seaport Beach	9	3	CG (estimated as 250)	3	35
Rotary Park Beach	9	3	>200	4	46

⁹ Based on the analytical results from the permit-required marine water sampling for commercial passenger vessels during the 2017 Ketchikan BEACH monitoring project (July 18-September 13), there were no exceedances of the Alaska WQS for fecal coliform bacteria from large cruise ships discharging while stationary (traveling under 6 knots) within Southeast Alaska, including near Ketchikan. Small cruise ships and ferries operate under Best Management Practices, they typically hold wastewater when stationary.

¹⁰ Bolded results exceed the Alaska Water Quality Standards (18 AAC 70 (14)(D)).

¹¹ Confluent growth

4.2 Enterococci

Presence of enterococci ranged from non-detect (<1.0 MPN/100 ml) to 2,419.6 MPN/100 ml. Eight of the nine monitoring sites failed to meet the enterococci criterion of “not more than 10% of the samples may exceed a statistical threshold value (STV) of 130 enterococci CFU/100 ml.” The Beach at Shull Road was the monitoring site that met the STV for enterococci. All nine of the monitoring sites failed to meet the Alaska WQS geometric mean for enterococci “in a 30-day period, the geometric mean of samples may not exceed 35 enterococci CFU/100 ml.” Table 6 shows the summary of enterococci results.

Table 6. Summary of Enterococci results

Monitoring locations	Enterococci results (CFU/100 mL)				
	Total # of samples	Total # of samples exceeding 130 CFU/100 ml STV ¹²	Maximum sample value	Total # of samples exceeding 35 CFU/100 mL geometric mean	Maximum geometric mean value
Knudson Cove	9	2	1986.3¹³	3	87
Beacon Hill	9	1	579.4	2	55
South Point Higgins Beach	9	1	1119.9	3	67
Beach at Shull Road	9	0	124.6	2	44
Beach at Sunset Drive	9	1	248.1	2	42
South Refuge Cove State Recreation Site	9	1	1299.7	3	60
Thomas Basin	9	3	2419.6	3	106
Seaport Beach	9	3	250.0	2	83
Rotary Park Beach	9	4	1119.9	4	437

4.3 MST

Based on the positive fecal coliform bacteria results found in the samples on August 8 and 9, 2017, all nine monitoring locations were analyzed for human bacteroidetes ID hosts. Further based on the beach recreation activities and congregation of sea birds, two locations (Thomas Basin and Rotary Beach) were analyzed for the additional tests of dog, gull and goose bacteroidetes ID hosts. Table 7 below depicts the host bacteria that were targeted and the final results of the analyses.

¹² STV – Statistical Threshold Value.

¹³ Bolded results exceed the Alaska Water Quality Standards (18 AAC 70 (14)(D)).

Table 7. Bacteria results comparison to MST results

Fecal coliform and enterococci results comparison to MST results ¹⁴						
Monitoring locations	Fecal coliform	Enterococci	MST			
			Human	Dog	Gull	Goose
Knudson Cove	98	1986.3	Present	- ¹⁵	-	-
Beacon Hill	11	579.4	Present	-	-	-
South Point Higgins Beach	7 (3)	1119.9 (980.4) ¹⁶	Present	-	-	-
Beach at Shull Road	4	75.9	Present	-	-	-
Beach at Sunset Drive	142	248.1	Present	-	-	-
South Refuge Cove State Recreation Site	8 (15)	1299.7 (157.8)	Present	-	-	-
Thomas Basin	42	86.2	Present	-	Present	-
Seaport Beach	21	204.6	Present	-	-	-
Rotary Park Beach	27	980.4	Present	Present	Present	Not Detected

¹⁴ Sample collection on August 8 & 9, 2017; one sample was collected and tested at each monitoring location.

¹⁵ ‘-’ denotes the sample was not analyzed.

¹⁶ () indicates a duplicate sample

5. Results Summary

All nine of the monitoring sites failed to meet the Alaska water quality standard single sample for fecal coliform bacteria, and seven of the nine monitoring sites failed to meet the Alaska WQS geometric mean for fecal coliform bacteria.¹⁷

Eight of the nine monitoring sites failed to meet the STV criterion for enterococci. All nine of the monitoring sites failed to meet the geometric mean criterion for enterococci.¹⁸

The human bacteroidetes ID was detected at all nine monitoring locations. Rotary Beach were tested for dog bacteroidetes ID, gull bacteroidetes ID, and goose bacteroidetes ID. Dog and gull bacteroidetes were present at this beach, but goose bacteroidetes were not detected. Thomas Basin was tested for gull bacteroidetes ID, which was present. Animal bacteroidetes were not tested at other sites.

5.1 Sanitary Surveys

Marine sanitary surveys were conducted at all nine monitoring locations during each of the nine sampling events. The EPA Marine Beach Sanitary Survey app was used to record water recreational and beach usage activities, wildlife, weather, water and air temperature, tidal conditions, and potential sources of pollution. Sanitary surveys summary tables with comparison to analytical results are attached as Appendix A. The survey observations of potential sources at each monitoring location are shown in Table 2. The following section provides discussion of how the sanitary survey observations and analytical results may relate to one another.

5.1.1 Discussion

The following summations are based on the sanitary survey observations and data as compared to the analytical data results.

- The combination of no rain, calm water with no turbidity, warm air temperatures (60-68 degrees Fahrenheit), and increased numbers of wildlife in early August coincided with elevated bacteria levels in the marine water samples.
- The combination of heavy rain (4.84 inches in 48 hours), turbid conditions, and increased numbers of wildlife in mid-August coincided with tests results of confluent bacteria growth¹⁹ and generally elevated bacteria levels in the marine water samples.

¹⁷ South Point Higgins Beach and South Refuge Cove State Recreation did not exceed the geometric mean for fecal coliform bacteria.

¹⁸ The Beach at Shull Road did not exceed the STV for enterococci.

¹⁹ A continuous bacterial growth covering all or part of the filtration area of a membrane filter in which the bacteria colonies are not discrete. If the growth of the bacteria covers almost the entire area of the membrane filter or culture media then it is known as confluent growth.

- Rotary Beach had numerous gulls (17-30) and ravens during 3 of the 9 monitoring events, and 1-4 dogs on several monitoring events. All of these observations coincided with moderate to elevated levels of bacteria in the marine waters.
- Most of the monitoring events at the Shull and Seaport monitoring locations had an abundance of gulls (15-57), shorebirds, some ravens and 1-2 dogs. These observations coincided with low to moderate levels of bacteria in the marine waters.
- Specific wildlife bacteroidetes (e.g., gull) were not tested at most of the monitoring locations are unknown. A more complete list of MST tests for wildlife hosts at all the monitoring locations is planned for the 2018 water recreation season.

5.1.2 PUBLIC OUTREACH

Four press releases were distributed between August 11 and September 18, 2017 providing detailed monitoring information and precautionary measurements to avoid exposure to bacteria impacted marine water. To further notify the public, the City of Ketchikan posted advisory signs at the beaches warning of elevated bacteria levels. Copies of these press releases are attached as Appendix F. The EPA Beach webpage provides detailed beach information, and can be found at <https://www.epa.gov/beaches>.

6. Conclusions

Marine water testing was conducted at nine Ketchikan coastal areas as part of the Alaska BEACH program. The program objective was to assess potential fecal waste contamination during the 2017 recreation season and if present at elevated levels to determine if human sources were a contributing factor. The fecal waste contamination in the coastal marine waters present a potential risk to human health. Commonly documented health issues from swimming in contaminated recreational waters include gastrointestinal illness, respiratory illnesses, skin rashes, and ear, eye, and wound infections.

Marine water samples were collected from mid-July to mid-September to evaluate potential health risks indicated by fecal coliform and enterococci bacteria, and to notify the public when levels exceeded safe recreation criteria. The recreation criteria were exceeded nearly every week from July 24 through August 29 at most of the nine locations. Based on these elevated bacteria levels and to determine the relative human health risk to beach users, samples were collected on August 8 and 9 for human bacteroidetes ID host testing to help determine the potential source(s). The testing outcome revealed that human fecal waste sources were associated with all of the nine monitoring locations along the Ketchikan coastline.

DEC plans to monitor a second recreation season in 2018 to evaluate the magnitude, frequency and duration of the fecal coliform and enterococci levels in the Ketchikan coastal marine waters, to identify potential bacteria sources with bacteroidetes ID host testing, and to notify the public when levels exceeded recreation criteria. The monitoring locations will include the nine high risk coastal areas sampled during the 2017 Ketchikan BEACH monitoring program, and include two additional coastal areas recommended by tribal members of the Our Way of Life Committee of Ketchikan.

The monitoring program will help support the development of recommendations for best management practices and wastewater treatment to reduce bacteria levels along the Ketchikan coastline. All potential bacteria sources will need to be better controlled to improve Ketchikan's marine waters.

7. References

Alaska Department of Environmental Conservation. 2017. 18 AAC 70, Water Quality Standards. Amended as of February 5, 2017.

U.S. Environmental Protection Agency. 2014. National Beach Guidance and Required Performance Criteria for Grants, 2014 Edition (dated July 31, 2014). EPA-823-B-14-001.

Alaska Department of Environmental Conservation. 2017. Ketchikan BEACH Water Quality Monitoring and Pathogen Detection Quality Assurance Project Plan (dated July 2017).

Alaska Department of Environmental Conservation. 2017. Ketchikan BEACH Monitoring Handbook (dated July 2017).

APPENDICES

Appendix A – Sanitary Survey Summary Tables with Comparison to Analytical Results

Appendix A – Sanitary Survey Summary Tables with Comparison to Analytical Results

Knudson Cove Sanitary Survey summary table																						
2017	Sample	rainfall "	rainfall "	air	rain	sky	wave	tidal	visual	#people	#people	#people	Boating-	Fishing-	Walking-	wildlife,	shorebirds	ducks	eagles	Fecal	Enterococcus	MST
sample	collection	in <24 hr	in <48 hr	temp	intensity	conditions	intensity	phase	turbidity	in water	out water	at beach	#people	#people	#people	gulls	ducks	presence	coliform	result	result	results
date	time															domestic animal			cfu/100 ml	MPN/100 ml		
18-Jul	11:15 AM		0.03	69	n/a	mostly cloudy	calm	ebbing	clear	0	75	0	20	5	30	0	0	0	2	16	5.1	
25-Jul	12:08 PM	0.20		59	n/a	partly sunny	normal	flooding	slightly turbid	0	50	0	35	0	15	15	5	0	0	5	3.0	
27-Jul	8:15 AM		0.33	56	misting	cloudy	calm	ebbing	clear	0	40	20	30	15	15	0	0	0	0	9	12.2	
31-Jul	10:52 AM			61	n/a	sunny	calm	ebbing	turbid	50	60	2	50	60	2	4	5	0	2	167	15.6	
9-Aug	5:25 AM		0	68	n/a	sunny	normal	ebbing	clear	0	0	2	0	0	2	0	4	8	0	98	1986.3	Human
15-Aug	9:15 AM	0.97		54	light rain	cloudy	calm	ebbing	clear	0	20	0	20	0	0	10	0	0	1	6 (9)	26.9 (26.3)	
23-Aug	8:58 AM		4.84	54	light rain	cloudy	calm	ebbing	slightly turbid	0	30	0	20	0	10	10	0	0	1	>200	488.4	
29-Aug	1:07 PM																			2	1.0	
13-Sep	12:35 PM		0	60	n/a	sunny	normal	low	slightly turbid	0	40	0	10	10	20	20	0	0	0	12	14.5	

Potential sources = private sewer treatment system outfall(s), individual septic tanks, wildlife, pet feces, boats in harbor areas.

Beacon Hill Sanitary Survey summary table																							
2017 sample date	Sample collection time	rainfall " in <24 hr	rainfall " in <48 hr	rainfall " in <72 hr	since last rain	air temp	rain intensity	sky conditions	wave intensity	tidal phase	visual turbidity	#people in water	#people out water	#people at beach	Boating - #people	Fishing - #people	Walking - #people	Sunbathing - #people	wildlife, domestic animal presence	Fecal coliform result	Enterococcus result	MST results	
18-Jul	12:06 PM		0.03			66	n/a	mostly cloudy	normal	ebbing	clear	0	13	0	8	5	0	10	40	5	1		
25-Jul	11:47 AM	0.20				59	n/a	mostly cloudy	normal	flooding	clear	0	8	0	8		0	0	0	2	<1		
27-Jul	8:40 AM	0.33				55	n/a	cloudy	calm	ebbing	clear	0	60	0	30	30	0	0	2	6	19.3		
31-Jul	11:12 AM			1.65		62	n/a	sunny	normal	ebbing	clear	0	0	0	0	0	0	0	0	2	6	26.6	
9-Aug	5:32 AM					68	n/a	sunny	normal	ebbing	clear	0	0	0	0	0	0	0	0	0	11	579.4	Human
15-Aug	9:51 AM	0.97				55	light rain	cloudy	calm	ebbing	clear	0	0	1	0	0	1	1	40	0	22	16.6	
23-Aug	9:22 AM		4.84			54	light rain	cloudy	calm	ebbing	clear	0	20	0	20	0	0	0	0	0	58	101.7	
29-Aug	12:50 PM		0.15			64	n/a	sunny	calm	low	clear	0	35	0	35	0	0	0	3	0	18	7.2	
13-Sep	12:15 PM		0.00			60	n/a	sunny	normal	low	clear	0	30	0	30	0	0	0	3	0	8	9.7	

Potential sources = private sewer treatment system outfall(s), individual septic tanks, wildlife.

South Point Higgins Sanitary Survey summary table																							
2017 sampling date	Sample collection time	rainfall " in <24 hr	rainfall " in <48 hr	rainfall " in <72 hr	since last rain	air temp	rain intensity	sky conditions	wave intensity	tidal phase	visual turbidity	#people in water	#people out water	#people at beach	Boating - #people	Fishing - #people	Walking - #people	Sunbathing - #people	wildlife, domestic animal presence	Fecal coliform result	Enterococcus result	MST results	
18-Jul	12:34 PM		0.03			66	n/a	cloudy	normal	ebbing	slightly turbid	0	0	0	0	0	0	0	0	0	<1	1.0	
25-Jul	11:17 AM	0.2				59	n/a	partly sunny	normal	flooding	clear	0	0	2	0	0	2	0	0	0	8	4.1	
27-Jul	9:14 AM	0.33				57		cloudy	normal	ebbing	clear	0	20	1	20	0	1	0	2	0	16(2)	7.4(23.8)	
31-Jul	11:37 AM			1.65		no data	no data	no data	no data	no data	clear	5	12	9	12	7	8	4	no data	no data	<1	13.1	Human
9-Aug	5:48 AM				0	68	n/a	sunny	normal	ebbing	clear	0	0	0	0	0	0	0	4	3	7(3)	1119.9(980.4)	
15-Aug	10:15 AM	0.97				55	heavy rain	cloudy	normal	ebbing	slightly turbid	0	0	0	0	0	0	0	2	0	161	82.3	
23-Aug	9:50 AM		4.84			54	light rain	cloudy	normal	flooding	turbid	0	0	4	0	4	0	0	0	0	37	46.2	
29-Aug	12:30 PM		0.15			66	n/a	mostly sunny	calm	low	clear	0	0	10	0	0	10	0	10	0	5	24.3	
13-Sep	11:55 AM		0			60	n/a	sunny	rough	ebbing	slightly turbid	0	0	0	0	0	0	0	0	0	2	9.5	

Potential sources = private/public sewer treatment system outfall(s), public treatment system emergency bypasses, individual septic tanks, wildlife, pet feces.

Shull Sanitary Survey summary table																									
2017 sampling date	Sample collection time	rainfall " in <24 hr	rainfall " in <48 hr	rainfall " in <72 hr	>72 hr since last rain	air temp	rain intensity	sky conditions	wave intensity	tidal phase	visual turbidity	#people in water	#people out water	#people at beach	Boating - #people	Fishing - #people	Walking - #people	Subbathing - #people	wildlife, domestic animal presence	Fecal coliform result	Enterococcus result	MST results			
18-Jul	1:04 PM		0.03			68	n/a	partly sunny	normal	ebbing	clear	0	0	0	0	0	0	4	gulls	0	8	6.2			
25-Jul	10:43 AM	0.2				59	n/a	mostly cloudy	normal	flooding	turbid	0	0	0	0	0	0	15	gulls	0	167 (68)	124.6 (81.3)			
27-Jul	9:32 AM		0.33			56	misting	cloudy	normal	no data	clear	0	2	0	2	0	0	33	4	2	0	0	12	27.5	
31-Jul	11:55 AM			1.65		61	n/a	sunny	normal	ebbing	clear	0	4	0	2	0	0	45	5	0	2	0	6	20.6	
9-Aug	6:05 AM				0	64	n/a	sunny	normal	ebbing	clear	0	0	0	0	0	0	5	20	2	0	2	4	75.9	Human
15-Aug	11:00 AM		0.97			55	steady rain	cloudy	normal	ebbing	slightly turbid	0	0	0	0	0	0	2	0	0	0	0	27	50.4	
23-Aug	10:17 AM		4.84			54	heavy rain	cloudy	rough	flooding	turbid	0	0	0	0	0	0	50	0	0	0	0	33	28.1	
29-Aug	12:15 PM		0.15			66	n/a	mostly sunny	calm	ebbing	slightly turbid	0	5	0	0	0	5	30	20	0	0	1	16	3.0	
13-Sep	11:32 AM		0			59	n/a	sunny	rough	ebbing	clear	0	0	3	0	0	3	50	0	0	0	1	9	8.4	

Potential sources = private/public sewer treatment system outfall(s), public treatment system emergency bypasses, individual septic tanks, wildlife, pet feces.

Sunset Sanitary Survey summary table																									
2017 sampling date	Sample collection time	rainfall " in <24 hr	rainfall " in <48 hr	rainfall " in <72 hr	>72 hr since last rain	air temp	rain intensity	sky conditions	wave intensity	tidal phase	visual turbidity	#people in water	#people out water	#people at beach	Boating - #people	Fishing - #people	Walking - #people	Subbathing - #people	wildlife, domestic animal presence	Fecal coliform result	Enterococcus result	MST results			
18-Jul	1:42 PM		0.03			69	n/a	mostly cloudy	calm	ebbing	turbid	0	0	0	0	0	0	0	0	gulls	<1 (<1)	4.1 (5.2)			
25-Jul	10:03 AM	0.2				59	n/a	mostly cloudy	normal	low	clear	0	0	0	0	0	0	0	10	3	5	0	16	8.5	
27-Jul	9:56 AM				0	68	n/a	sunny	normal	ebbing	clear	0	0	2	0	0	2	0	3	3	0	1	13	10.9	
31-Jul	12:13 PM			1.65		63	n/a	sunny	normal	ebbing	clear	0	1	0	0	0	1	0	4	0	2	1	41 (8)	34.1 (45.4)	
9-Aug	6:20 AM				0	62	n/a	sunny	normal	ebbing	clear	0	0	0	0	0	0	0	2	1	0	0	142	248.1	Human
15-Aug	8:58 AM	0.97				55	light rain	cloudy	normal	ebbing	clear	0	0	0	0	0	0	0	0	0	0	0	15	22.5	
23-Aug	10:45 AM		4.84			54	heavy rain	cloudy	calm	floodin g	clear	0	0	0	0	0	0	0	0	0	0	0	51 (29)	33.7 (47.4)	
29-Aug	11:56 AM		0.145			66	n/a	mostly sunny	calm	ebbing	slightly turbid	0	0	6	0	0	0	6	10	0	0	1	3 (2)	<1 (8.5)	
13-Sep	11:15 AM		0			58	n/a	sunny	rough	ebbing	slightly turbid	0	0	1	0	0	1	0	0	0	0	0	17	9.5	

Potential sources = private/public sewer treatment system outfall(s), individual septic tanks, wildlife, pet feces.

Refuge Cove Sanitary Survey summary table																						
2017 sampling date	Sample collection time	rainfall " in <24 hr	rainfall " in <48 hr	rainfall " in <72 hr	>72 hr rain event	air temp	rain intensity	sky conditions	wave intensity	tidal phase	visual turbidity	#people in water	#people out water	#people at beach	Boating - #people	Fishing - #people	Walking - #people	wildlife, domestic animal presence	Fecal coliform result	Enterococcus result	MST results	
19-Jul	2:45 PM			0.03		63	n/a	mostly sunny	normal	ebbing	slightly turbid	0	0	0	0	0	0	gulls	0	11	2.0	
24-Jul	10:43 AM		1.5			59	n/a	cloudy	calm	flooding	clear	0	0	0	0	0	0	0	0	11 (7)	6.1 (5.2)	
26-Jul	9:16 AM		0.5			56	light rain	cloudy	normal	ebbing	turbid	0	0	0	0	0	0	0	0	8	12.1	
1-Aug	1:46 PM		0.79			66	n/a	mostly sunny	normal	ebbing	clear	0	4	6	6	0	4	0	0	7	26.6	
8-Aug	7:00 AM				0	61	n/a	mostly sunny	normal	ebbing	clear	0	0	0	0	0	0	0	5	8 (15)	1299.7 (157.8)	Human
14-Aug	12:35 PM		0.49			56	n/a	cloudy	n/a	flooding	clear	0	0	0	0	0	0	0	0	6	21.3	
22-Aug	10:38 AM		4.53			60	heavy rain	cloudy	rough	flooding	turbid	0	0	0	0	0	0	20	0	69 (32)	81.6 (57.8)	
29-Aug	11:42 AM		0.15			66	n/a	mostly sunny	calm	ebbing	slightly turbid	0	0	0	0	0	0	30	0	7	13.0	
13-Sep	10:50 AM		0			57	n/a	sunny	rough	ebbing	clear	0	0	0	0	0	0	10	0	4	13.5	

Potential sources = private/public sewer treatment system outfall(s), public treatment system emergency bypasses, individual septic tanks, wildlife, pet feces.

Thomas Basin Sanitary Survey summary table																									
2017 sampling date	Sample collection time	rainfall " in <24 hr	rainfall " in <48 hr	rainfall " in <72 hr	>72hr since last rain event	air temp	rain intensity	sky conditions	wave intensity	tidal phase	visual turbidity	#people in water	#people outwater	#people at beach	#people Boating -	Fishing - #people	Walking - #people	Sunbathing - #people	wildlife, domestic animal presence	gulls	dogs	harbor seals	Fecal coliform result	Enterococcus result	MST results
19-Jul	1:58 PM		0.03			63	n/a	partly sunny	normal	ebbing	clear	0	8	8	0	3	5	0	0				5.0	2.0	
24-Jul	10:02 AM		1.5			59	n/a	cloudy	calm	high	slightly turbid	0	50	0	0	0	50	0	2				9.0	4.1	
26-Jul	8:37 AM		0.5			56	light rain	cloudy	normal	ebbing	turbid	0	0	0	0	0	0	0	0				14.0	>2419.6	
1-Aug	1:12 PM	0.79				67	n/a	mostly sunny	calm	ebbing	slightly turbid	0	0	0	0	0	0	0	3				7.0	3.0	Human,
8-Aug	5:50 AM				0	no data	n/a	mostly sunny	normal	ebbing	clear	0	8	0	0	0	4	4	0				42.0	86.2	gull
14-Aug	11:55 AM	0.49				56	n/a	cloudy	calm	flooding	clear	0	30	100	20	10	100	0	0				36	156.5	
22-Aug	10:08 AM	4.53				60	heavy rain	cloudy	rough	flooding	turbid	0	0	10	0	0	10	0	0				CG (250)	137.4	
29-Aug	11:10 AM		0.15			66	n/a	mostly sunny	calm	ebbing	slightly turbid	0	17	0	0	7	10	0	0				<1	14.5	
13-Sep	10:20 AM		0			57	n/a	sunny	normal	ebbing	slightly turbid	0	0	20	0	2	18	0	15				13	70.3	

Potential sources = private/public sewer treatment system outfall(s), public treatment system emergency bypasses, sewer line breaks, individual septic tanks, wildlife, pet feces, boats in harbor areas.

Seaport Sanitary Survey summary table

2017 sampling date	Sample collection time	rainfall " in <24 hr	rainfall " in <48 hr	rainfall " in <72 hr	>72hr since last rain event	air temp	rain intensity	sky conditions	wave intensity	tidal phase	visual turbidity	#people in water	#people out water	#people at beach	Boating - #people	Fishing - #people	Walking - #people	wildlife, domestic animal presence	gulls	shorebirds	ravens	Fecal coliform result	Enterococcus result	MST results	
19-Jul	1:26 PM			0.03		63	n/a	mostly cloudy	rough	ebbing	clear	0	0	0	0	0	0	0	15			0	3 (<1)	3 (3.1)	
24-Jul	9:33 AM		1.5			59	n/a	partly sunny	calm	flooding	clear	0	1	0	0	0	1	30	20			0	7.0	2.0	
26-Jul	7:17 AM		0.5			56	misting	cloudy	normal	ebbing	slightly turbid	0	5	0	0	0	0	10	5			0	3.0	7.3	
1-Aug	12:41 PM		0.79			67	n/a	mostly sunny	normal	ebbing	clear	0	4	0	4	0	0	10	40			7	4 (7)	3.1 (26.6)	
8-Aug	6:20 AM				0	60	n/a	mostly sunny	normal	ebbing	clear	0	0	0	0	0	0	0	8			0	21.0	204.6	Human
14-Aug	11:32 AM	0.49				55	misting	cloudy	calm	ebbing	clear	0	20	20	20	0	20	20	0			0	37.0	21.1	
22-Aug	9:47 AM	4.53				59	heavy rain	cloudy	rough	flooding	clear	0	0	0	0	0	0	20	0			0	CG (250)	250.0	
29-Aug	10:52 AM		0.15			66	n/a	mostly sunny	calm	ebbing	clear	0	6	0	6	0	0	20	0			0	41.0	135.4	
13-Sep	9:55 AM		0			56	n/a	mostly sunny	normal	ebbing	clear	0	0	0	0	0	0	35	0			3	21 (22)	12 (21.3)	

Potential sources = private/public sewer treatment system outfall(s), public treatment system emergency bypasses, sewer line breaks, individual septic tanks, wildlife, pet feces, boat launch area.

Rotary Sanitary Survey summary table																											
2017 sampling date	Sample collection time	rainfall " in <24 hr	rainfall " in <48 hr	rainfall " in <72 hr	>72 hr since last rain	air temp	rain intensity	sky conditions	wave intensity	tidal phase	visual turbidity	#people in water	#people out water	#people at beach	Boating - #people	Fishing - #people	Walking - #people	Swimming - #people	Sunbathing - #people	wildlife, gulls	domestic animals	animal presence	Fecal coliform result	Enterococcus result	MST results		
19-Jul	12:58 PM			0.03		63	n/a	mostly cloudy	normal	ebbing	slightly turbid	2	16	18	0	0	18	2	0	0	0	2	0	0	6.0	3.0	
24-Jul	9:11 AM		1.5				n/a	cloudy	calm	flooding	clear	2	21	14	0	1	18	2	0	0			0	2	68.0	45.7	
26-Jul	6:30 AM		0.5			57	misting	cloudy	normal	ebbing	slightly turbid	0	0	1	0	0	1	0	0	0	0	0	0	0	99 (137)	980.4 (579.4)	
1-Aug	12:22 PM		0.79			67	n/a	sunny	normal	ebbing	clear	9	2	21	1	1	15	9	6	6	17	0	0	4	9.0	47.4	
8-Aug	5:30 AM				0	60	n/a	mostly sunny	calm	ebbing	clear	0	0	0	0	0	0	0	0	0	0	0	18	0	27.0	980.4	Human, dog, gull
14-Aug	11:15 AM	0.49				55	n/a	cloudy	calm	ebbing	clear	0	10	3	10	0	3	0	0	0	0	0	0	0	21 (11)	69.7 (313.0)	
22-Aug	9:32 AM	4.53				59	heavy rain	cloudy	normal	flooding	clear	0	0	1	0	0	1	0	0	0	0	0	0	0	>200	1119.9	
29-Aug	10:40 AM		0.15			66	n/a	mostly sunny	calm	ebbing	clear	0	0	7	0	0	7	0	0	0	0	0	0	0	9.0	69.3	
13-Sep	9:38 AM		0			55	n/a	mostly sunny	normal	ebbing	slightly turbid	0	0	3	0	0	3	0	0	0	30	0	0	1	6.0	26.2	

Potential sources = private/public sewer treatment system outfall(s), public treatment system emergency bypasses, sewer line breaks, individual septic tanks, wildlife, pet feces.

Appendix B – Chain of Custody and Laboratory Analytical Reports



R&M ENGINEERING-KETCHIKAN, INC.
 355 Carlanna Lake Road, Ketchikan AK 99901
 phone 907-2257917 / fax 907-225-3441

Forbes

Chain of Custody ~~465-5023~~ ~~9312~~

Report Attention: Gretchen Pikul + Nicole	Phone Number: 907-465-5023 SP
Company Name: DEC Div of Water	Fax Number: 907-228-9312 NF
Address: 410 Willoughby Avenue	Sampler Name (Print): Forbes - Pikul
City, State, Zip Juneau, AK 99811	Sampler Signature: Gretchen Pikul

Sample Information

Sample Location	Sample Matrix (waste, drinking, storm)	Date	Time	Grab/Comp	Analysis Requested
KB-Knudson Cove	marine water	7-18-17	11:15am	grab	FC SM 9222D
"	"	"	11:15am	"	Enteroto D6503-99
KB-Beacon Hill	"	"	12:06pm	"	FC
"	"	"	"	"	Enteroto
KB-SP Higgins	"	"	12:34pm	"	FC
"	"	"	"	"	Enteroto
KB-Shull	"	"	1:04pm	"	FC
"	"	"	"	"	Enteroto
KB-Sunset	"	"	1:42pm	"	FC
"	"	"	"	"	Enteroto

Wastewater samples are accepted Mon-Thurs 8:00-3:00 and must be received within 6 hours of collection. If more than 2 hours elapses between collection and receipt, the samples must be refrigerated or stored in a cooler with blue ice. If bottle contains preservative, take caution not to overfill; otherwise, simply fill bottles with representative sample, leaving a 1-inch air space for laboratory homogenization. It's important that this form is properly completed by the sampler, if you have questions feel free to contact the lab.

KB-Settlers	"	"	2:05pm	"	FC
FIELD NOTES:	"	"	"	"	Enteroto

receiving temp = 9.5°C

Tracking Information

Relinquished By:	Date	Time	Received By:	Date	Time
			<i>[Signature]</i>	7/18/17	1420

* Please notify preliminary results asap on July 19 to:
 Gretchen Pikul 465-5023 gretchen.pikul@alaska.gov
 Nicole Forbes 228-9312 nforbes@kictribe.org
 Tami Gallegos 228-9312 tgallegos@kictribe.org



R&M ENGINEERING-KETCHIKAN, INC.
ENGINEERS GEOLOGISTS SURVEYORS

355 CARLANNA LAKE ROAD, SUITE 200, KETCHIKAN, ALASKA 99901
 PHONE (907) 225-7917 FAX (907) 225-3441 EMAIL: RNMI@mketchikan.com

ADEC Division of Water
 Attn: Gretchen Pikul
 410 Willoughby Ave
 Jumeau, AK 99811

Ketchikan BEACH

Sampler: Gretchen Pikul / Nicole Forbes
 Date: 7/18/2017
 Time: 1115-1405
 Matrix: Marine water
 Type: Grab

LAB RECEIVING

Date: 7/18/2017
 Time: 1420

LAB REPORTING

Date: 7/21/2017
 Time: 1030

ANALYST: JML

Lab #	Sample Name	Analysis	Date Tested	Time Tested	Results	Units	MRL	Method
23356	KB-Knudson Cove	FC	7/18/2017	1440	16	cfu / 100 ml	1.0	9222D
		ENTERO	7/18/2017	1535	5.1	MPN / 100 ml	1.0	D6503
23359	KB-Beacon Hill	FC	7/18/2017	1440	5	cfu / 100 ml	1.0	9222D
		ENTERO	7/18/2017	1535	1.0	MPN / 100 ml	1.0	D6503
23360	KB-S Pt Higgins	FC	7/18/2017	1440	<1	cfu / 100 ml	1.0	9222D
		ENTERO	7/18/2017	1535	1.0	MPN / 100 ml	1.0	D6503
23357	KB-Shull	FC	7/18/2017	1440	8	cfu / 100 ml	1.0	9222D
		ENTERO	7/18/2017	1535	6.2	MPN / 100 ml	1.0	D6503
23358	KB-Sunset	FC	7/18/2017	1440	<1	cfu / 100 ml	1.0	9222D
		ENTERO	7/18/2017	1535	4.1	MPN / 100 ml	1.0	D6503
23361	KB-Settlers	FC	7/18/2017	1440	<1	cfu / 100 ml	1.0	9222D
		ENTERO	7/18/2017	1535	5.2	MPN / 100 ml	1.0	D6503

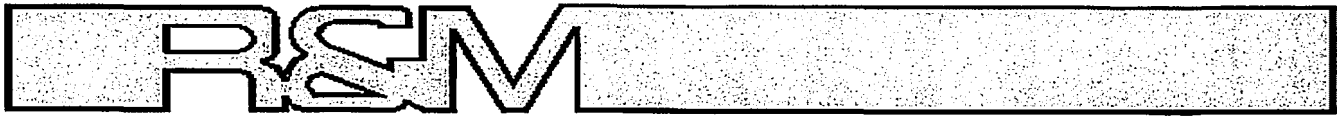

R&M ENGINEERING-KETCHIKAN, INC.
 355 Carlanna Lake Road, Ketchikan AK 99901
 phone 907-2257917 / fax 907-225-3441

Chain of Custody

Report Attention: <i>Gretchen Pikul & Nicole Forbes</i>	Phone Number: <i>907-228-9312</i>
Company Name: <i>DEC Div of Water</i>	Fax Number:
Address: <i>410 Willoughby Avenue</i>	Sampler Name (Print): <i>Nicole Forbes</i>
City, State, Zip: <i>Juneau, AK 99811</i>	Sampler Signature: <i>Nicole Forbes</i>

Sample Information

Sample Location	Sample Matrix <small>(waste, drinking, storm)</small>	Date	Time	Grab/Comp	Analysis Requested
<i>KB-Rotary</i>	<i>marine water</i>	<i>7/19/17</i>	<i>12:58pm</i>	<i>grab</i>	<i>FC, SM 9222D</i>
<i>"</i>	<i>"</i>	<i>"</i>	<i>"</i>	<i>"</i>	<i>Enteroto P6503-99</i>
<i>KB-Seaport</i>	<i>"</i>	<i>"</i>	<i>1:26pm</i>	<i>"</i>	<i>FC</i>
<i>"</i>	<i>"</i>	<i>"</i>	<i>1:26pm</i>	<i>"</i>	<i>Enteroto</i>
<i>KB-Mtn Point</i>	<i>"</i>	<i>"</i>	<i>1:40pm</i>	<i>"</i>	<i>FC</i>
<i>"</i>	<i>"</i>	<i>"</i>	<i>"</i>	<i>"</i>	<i>Enteroto</i>
<i>KB-Thomas Basin</i>	<i>"</i>	<i>"</i>	<i>1:58pm</i>	<i>"</i>	<i>FC</i>
<i>"</i>	<i>"</i>	<i>"</i>	<i>"</i>	<i>"</i>	<i>Enteroto</i>
<i>KB-Refuge</i>	<i>"</i>	<i>"</i>	<i>2:45pm</i>	<i>"</i>	<i>FC</i>
<i>"</i>	<i>"</i>	<i>"</i>	<i>"</i>	<i>"</i>	<i>Enteroto</i>

Please complete top portion of form. Wastewater samples are accepted Mon-Thurs 8:00-3:00 and must be received within 6 hours of collection. If more than 2 hours elapses between collection and receipt, the samples must be refrigerated or stored in a cooler with ice. Fill bottles to shoulder with sample, leaving a 1-inch air space for laboratory homogenization. If bottles contain preservative, take caution not to overfill.
 Standard turnaround time is 10-days.

FIELD NOTES: *receiving temp = 10.0°C je*

Tracking Information

Relinquished By:	Date	Time	Received By:	Date	Time
			<i>[Signature]</i>	<i>7/19/17</i>	<i>1515</i>

* Please notify preliminary results via email asap to:
 Gretchen Pikul gretchen.pikul@alaska.gov
 Nicole Forbes nforbes@kictribe.org
 Tami Gallinas t.gallinas@kictribe.org



R&M ENGINEERING-KETCHIKAN, INC.
ENGINEERS GEOLOGISTS SURVEYORS

355 CARLANNA LAKE ROAD, SUITE 200, KETCHIKAN, ALASKA 99901
PHONE (907) 225-7917 FAX (907) 225-3441 EMAIL: RNMMain@mketchikan.com

ADEC Division of Water
Attn: Gretchen Pikul
410 Willoughby Ave
Jumeau, AK 99811

Ketchikan BEACH

Sampler: Nicole Forbes
Date: 7/19/2017
Time: 1258-1445
Matrix: Marine water
Type: Grab

LAB RECEIVING

Date: 7/19/2017
Time: 1515

LAB REPORTING

Date: 7/21/2017
Time: 1045

ANALYST: JML

Lab #	Sample Name	Analysis	Date Tested	Time Tested	Results	Units	MRL	Method
23372	KB-Rotary	FC	7/19/2017	1610	6	cfu / 100 ml	1.0	9222D
		ENTERO	7/19/2017	1640	3.0	MPN / 100 ml	1.0	D6503
23373	KB-Seaport	FC	7/19/2017	1610	3	cfu / 100 ml	1.0	9222D
		ENTERO	7/19/2017	1640	3.0	MPN / 100 ml	1.0	D6503
23374	KB-Mt Point	FC	7/19/2017	1610	<1	cfu / 100 ml	1.0	9222D
		ENTERO	7/19/2017	1640	3.1	MPN / 100 ml	1.0	D6503
23375	KB-Thomas Basin	FC	7/19/2017	1610	5	cfu / 100 ml	1.0	9222D
		ENTERO	7/19/2017	1640	2.0	MPN / 100 ml	1.0	D6503
23376	KB-Refuge	FC	7/19/2017	1610	11	cfu / 100 ml	1.0	9222D
		ENTERO	7/19/2017	1640	2.0	MPN / 100 ml	1.0	D6503

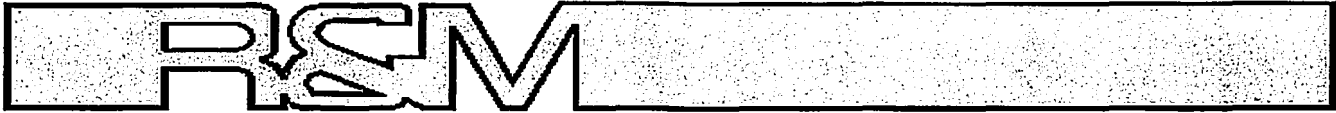

R&M ENGINEERING-KETCHIKAN, INC.
 355 Carlanna Lake Road, Ketchikan AK 99901
 phone 907-2257917 / fax 907-225-3441

Chain of Custody

Report Attention: <u>NICOLE FORDES & Gretchen Pickel</u>	Phone Number: <u>907-465-5075</u>
Company Name: <u>DEC Div of Water</u>	Fax Number:
Address: <u>410 Willoughby Avenue</u>	Sampler Name (Print): <u>NICOLE FORDES</u>
City, State, Zip: <u>Juneau, AK 99811</u>	Sampler Signature: <u>Nicole Fordes</u>

Sample Information

Sample Location	Sample Matrix <small>(waste, drinking, storm)</small>	Date	Time	Grab/Comp	Analysis Requested
<u>KB-Rotary</u>	<u>Marine</u>	<u>7-24-17</u>	<u>9:11am</u>	<u>grab</u>	<u>FC SM 9222B</u>
"	"	"	"	<u>J11</u>	<u>Enterol D0503-99</u>
<u>KB-Seaport</u>	"	"	<u>9:33am</u>	"	<u>FC</u>
"	"	"	"	"	<u>Enterol</u>
<u>KB-Thomas Basin</u>	"	"	<u>10:02am</u>	"	<u>FC</u>
"	"	"	"	"	<u>Enterol</u>
<u>KB-Mt Point</u>	"	"	<u>9:45am</u>	"	<u>FC</u>
"	"	"	"	"	<u>Enterol</u>
<u>KB-S Refuge</u>	"	"	<u>10:43am</u>	"	<u>FC</u>
"	"	"	"	"	<u>Enterol</u>

Please complete top portion of form. Wastewater samples are accepted Mon-Thurs 8:00-3:00 and must be received within 6 hours of collection. If more than 2 hours elapses between collection and receipt, the samples must be refrigerated or stored in a cooler with ice. Fill bottles to shoulder with sample, leaving a 1-inch air space for laboratory homogenization. If bottles contain preservative, take caution not to overfill.
 Standard turnaround time is 10-days.

FIELD NOTES: receiving temp = 9.0°C

Tracking Information

Relinquished By:	Date	Time	Received By:	Date	Time
			<u>[Signature]</u>	<u>7/24/17</u>	<u>1110</u>



R&M ENGINEERING-KETCHIKAN, INC.
ENGINEERS GEOLOGISTS SURVEYORS

355 CARLAINNA LAKE ROAD, SUITE 200, KETCHIKAN, ALASKA 99901
PHONE (907) 225-7917 FAX (907) 225-3441 EMAIL: RNMI@mketchikan.com

ADEC Division of Water
Attn: Gretchen Pikul
410 Willoughby Ave
Jumeau, AK 99811

Ketchikan BEACH

Sampler: Nicole Forbes
Date: 7/24/2017
Time: 0911-1043
Matrix: Marine water
Type: Grab

LAB RECEIVING

Date: 7/24/2017
Time: 1110

LAB REPORTING

Date: 7/27/2017
Time: 1440

ANALYST: JML

Lab #	Sample Name	Analysis	Date Tested	Time Tested	Results	Units	MRL	Method
23395	KB-Rotary	FC	7/24/2017	1630	68	cfu / 100 ml	1.0	9222D
		ENTERO	7/24/2017	1640	45.7	MPN / 100 ml	1.0	D6503
23396	KB-Seaport	FC	7/24/2017	1630	7	cfu / 100 ml	1.0	9222D
		ENTERO	7/24/2017	1640	2.0	MPN / 100 ml	1.0	D6503
23397	KB-Thomas Basin	FC	7/24/2017	1630	9	cfu / 100 ml	1.0	9222D
		ENTERO	7/24/2017	1640	4.1	MPN / 100 ml	1.0	D6503
23398	KB-Mt Point	FC	7/24/2017	1630	7	cfu / 100 ml	1.0	9222D
		ENTERO	7/24/2017	1640	5.2	MPN / 100 ml	1.0	D6503
23399	KB-S Refuge	FC	7/24/2017	1630	11	cfu / 100 ml	1.0	9222D
		ENTERO	7/24/2017	1640	6.1	MPN / 100 ml	1.0	D6503



R&M ENGINEERING-KETCHIKAN, INC.
 355 Carlanna Lake Road, Ketchikan AK 99901
 phone 907-2257917 / fax 907-225-3441

Chain of Custody

Report Attention: <i>Ketchikan Pkwy & Nicol Forbes</i>	Phone Number: <i>907-465-5023</i>
Company Name: <i>DEC Div of Water</i>	Fax Number:
Address: <i>410 Willoughby Ave</i>	Sampler Name (Print): <i>NICOL FORBES</i>
City, State, Zip: <i>UNALASKA AK 99811</i>	Sampler Signature: <i>Nicol Forbes</i>

Sample Information

Sample Location	Sample Matrix (waste, drinking, storm)	Date	Time	Grab/Comp	Analysis Requested
<i>KB-Sunset</i>	<i>marine</i>	<i>07/25/17</i>	<i>10:03am</i>	<i>grab</i>	<i>FC SM 9222 D</i>
<i>"</i>	<i>"</i>	<i>"</i>	<i>"</i>	<i>"</i>	<i>Enteroto 06503-99</i>
<i>KB-Shull</i>	<i>"</i>	<i>"</i>	<i>10:43am</i>	<i>"</i>	<i>FC</i>
<i>"</i>	<i>"</i>	<i>"</i>	<i>"</i>	<i>"</i>	<i>Enteroto</i>
<i>KB-SP Higgins</i>	<i>"</i>	<i>"</i>	<i>11:17am</i>	<i>"</i>	<i>FC</i>
<i>"</i>	<i>"</i>	<i>"</i>	<i>"</i>	<i>"</i>	<i>Enteroto</i>
<i>KB-Beacon Hill</i>	<i>"</i>	<i>"</i>	<i>11:47am</i>	<i>"</i>	<i>FC</i>
<i>"</i>	<i>"</i>	<i>"</i>	<i>"</i>	<i>"</i>	<i>Enteroto</i>
<i>KB-Knaudson</i>	<i>"</i>	<i>"</i>	<i>12:08pm</i>	<i>"</i>	<i>FC</i>
<i>"</i>	<i>"</i>	<i>"</i>	<i>"</i>	<i>"</i>	<i>Enteroto</i>

Wastewater samples are accepted Mon-Thurs 8:00-3:00 and must be received within 6 hours of collection. If more than 2 hours elapses between collection and receipt, the samples must be refrigerated or stored in a cooler with blue ice. If bottle contains preservative, take caution not to overfill; otherwise, simply fill bottles with representative sample, leaving a 1-inch air space for laboratory homogenization. It's important that this form is properly completed by the sampler, if you have questions feel free to contact the lab.

<i>KB-Settler's</i>	<i>"</i>	<i>"</i>	<i>11:45am</i>	<i>"</i>	<i>FC</i>
<i>FIELD NOTES:</i>	<i>"</i>	<i>"</i>	<i>11:45am</i>	<i>"</i>	<i>Enteroto</i>

7° C upon receipt

Tracking Information

Relinquished By:	Date	Time	Received By:	Date	Time
<i>Nicol Forbes</i>	<i>07/25/17</i>	<i>12:53pm</i>	<i>[Signature]</i>	<i>7/25/17</i>	<i>1400</i>



R&M ENGINEERING-KETCHIKAN, INC.
ENGINEERS GEOLOGISTS SURVEYORS

355 CARLANNA LAKE ROAD, SUITE 200, KETCHIKAN, ALASKA 99901
 PHONE (907) 225-7917 FAX (907) 225-3441 EMAIL: RNMMain@mketchikan.com

ADEC Division of Water
 Attn: Gretchen Pikul
 410 Willoughby Ave
 Jumeau, AK 99811

Ketchikan BEACH

Sampler: Nicole Forbes
 Date: 7/25/2017
 Time: 1003-1208
 Matrix: Marine water
 Type: Grab

LAB RECEIVING

Date: 7/25/2017
 Time: 1400

LAB REPORTING

Date: 7/27/2017
 Time: 1500

ANALYST: JML

Lab #	Sample Name	Analysis	Date Tested	Time Tested	Results	Units	MRL	Method
23410	KB-Sunset	FC	7/25/2017	1630	16	cfu / 100 ml	1.0	9222D
		ENTERO	7/25/2017	1650	8.5	MPN / 100 ml	1.0	D6503
23411	KB-Shull	FC	7/25/2017	1630	167	cfu / 100 ml	1.0	9222D
		ENTERO	7/25/2017	1650	124.6	MPN / 100 ml	1.0	D6503
23412	KB-S Pt Higgins	FC	7/25/2017	1630	8	cfu / 100 ml	1.0	9222D
		ENTERO	7/25/2017	1650	4.1	MPN / 100 ml	1.0	D6503
23413	KB-Beacon Hill	FC	7/25/2017	1630	2	cfu / 100 ml	1.0	9222D
		ENTERO	7/25/2017	1650	<1	MPN / 100 ml	1.0	D6503
23414	KB-Knudson	FC	7/25/2017	1630	5	cfu / 100 ml	1.0	9222D
		ENTERO	7/25/2017	1650	3.0	MPN / 100 ml	1.0	D6503
23415	KB-Settlers	FC	7/25/2017	1630	68	cfu / 100 ml	1.0	9222D
		ENTERO	7/25/2017	1650	81.3	MPN / 100 ml	1.0	D6503



R&M ENGINEERING-KETCHIKAN, INC.
355 Carlanna Lake Road, Ketchikan AK 99901
phone 907-2257917 / fax 907-225-3441

Chain of Custody

Report Attention: Gretchen P. Ull	Phone Number: 907-465-5023
Company Name: DEC Div of Water	Fax Number:
Address: 410 Willoughby Ave	Sampler Name (Print): Nicole Forbes
City, State, Zip JUNEAU, AK 99801	Sampler Signature: Nicole Forbes

Sample Information

Sample Location	Sample Matrix (waste, drinking, storm)	Date	Time	Grab/Comp	Analysis Requested
KB-MtInPoint	marine	7/26/17	6:30am	grab	FC
"	"	"	"	"	
KB-Rotary	"	"	6:45am	"	
"	"	"	"	"	
KB-SCAPORT	"	"	7:17am	"	
"	"	"	"	"	
KB-ThomasBasin	"	"	8:37am	"	
"	"	"	"	"	
KB-Refuge	"	"	9:16am	"	
"	"	"	"	"	

Wastewater samples are accepted Mon-Thurs 8:00-3:00 and must be received within 6 hours of collection. If more than 2 hours elapses between collection and receipt, the samples must be refrigerated or stored in a cooler with blue ice. If bottle contains preservative, take caution not to overfill; otherwise, simply fill bottles with representative sample, leaving a 1-inch air space for laboratory homogenization. It's important that this form is properly completed by the sampler, if you have questions feel free to contact the lab.

FIELD NOTES: receiving temp = 2° C

Tracking Information

Relinquished By:	Date	Time	Received By:	Date	Time
Nicole Forbes	7/26/17		C. J. J. J. J.	7/26/17	0940



R&M ENGINEERING-KETCHIKAN, INC.
ENGINEERS GEOLOGISTS SURVEYORS

355 CARLANNA LAKE ROAD, SUITE 200, KETCHIKAN, ALASKA 99901
 PHONE (907) 225-7917 FAX (907) 225-3441 EMAIL: RNMMain@mketchikan.com

ADEC Division of Water
 Attn: Gretchen Pikul
 410 Willoughby Ave
 Jumeau, AK 99811

Ketchikan BEACH

Sampler: Nicole Forbes
 Date: 7/26/2017
 Time: 0630-0916
 Matrix: Marine water
 Type: Grab

LAB RECEIVING

Date: 7/26/2017
 Time: 940

LAB REPORTING

Date: 7/28/2017
 Time: 1115

ANALYST: JML

Lab #	Sample Name	Analysis	Date Tested	Time Tested	Results	Units	MRL	Method
23410	KB-Mt. Pt.	FC	7/26/2017	1535	137	cfu / 100 ml	1.0	9222D
		ENTERO	7/26/2017	1610	579.4	MPN / 100 ml	1.0	D6503
23411	KB-Rotary	FC	7/26/2017	1535	99	cfu / 100 ml	1.0	9222D
		ENTERO	7/26/2017	1610	980.4	MPN / 100 ml	1.0	D6503
23412	KB-Seaport	FC	7/26/2017	1535	3	cfu / 100 ml	1.0	9222D
		ENTERO	7/26/2017	1610	7.3	MPN / 100 ml	1.0	D6503
23413	KB-Thomas Basin	FC	7/26/2017	1535	14	cfu / 100 ml	1.0	9222D
		ENTERO	7/26/2017	1610	>2419.6	MPN / 100 ml	1.0	D6503
23414	KB-Refuge	FC	7/26/2017	1535	8	cfu / 100 ml	1.0	9222D
		ENTERO	7/26/2017	1610	12.1	MPN / 100 ml	1.0	D6503

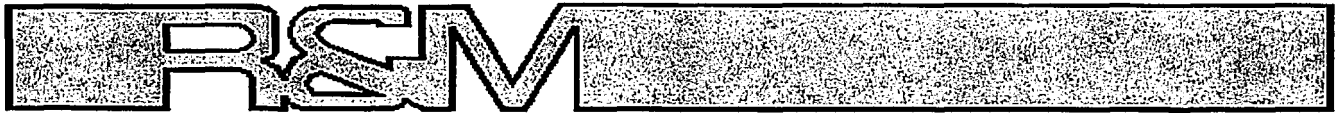

R&M ENGINEERING-KETCHIKAN, INC.
 355 Carlanna Lake Road, Ketchikan AK 99901
 phone 907-2257917 / fax 907-225-3441

Chain of Custody

Report Attention: <i>Greening Pickle Alime Forbes</i>	Phone Number: <i>907-465-5028</i>
Company Name: <i>DEF Dist of Water</i>	Fax Number:
Address: <i>410 Willoughby Ave</i>	Sampler Name (Print): <i>Nicole Forbes</i>
City, State, Zip: <i>JUNEAU, AK 99811</i>	Sampler Signature: <i>Nicole Forbes</i>

Sample Information

Sample Location	Sample Matrix (waste, drinking, storm)	Date	Time	Grab/Comp	Analysis Requested
<i>KB-KNUCKSON</i>	<i>WASTEW</i>	<i>07/27/17</i>	<i>8:35am</i>	<i>grab</i>	<i>FC SW 9227D</i>
<i>"</i>	<i>"</i>	<i>"</i>	<i>"</i>	<i>"</i>	<i>ENTERO D6503-99</i>
<i>KB-Beacon Hill</i>	<i>"</i>	<i>"</i>	<i>8:40am</i>	<i>"</i>	<i>FC</i>
<i>"</i>	<i>"</i>	<i>"</i>	<i>"</i>	<i>"</i>	<i>ENTERO</i>
<i>KB-SP Higgins</i>	<i>"</i>	<i>"</i>	<i>9:14am</i>	<i>"</i>	<i>FC</i>
<i>"</i>	<i>"</i>	<i>"</i>	<i>"</i>	<i>"</i>	<i>ENTERO</i>
<i>KB-Shull</i>	<i>"</i>	<i>"</i>	<i>9:37am</i>	<i>"</i>	<i>FC</i>
<i>"</i>	<i>"</i>	<i>"</i>	<i>"</i>	<i>"</i>	<i>ENTERO</i>
<i>KB-Sunset</i>	<i>"</i>	<i>"</i>	<i>9:56am</i>	<i>"</i>	<i>FC</i>
<i>"</i>	<i>"</i>	<i>"</i>	<i>"</i>	<i>"</i>	<i>ENTERO</i>

1301/17
5437
5438
5439
5440

9
11/0
6
12/5
16
6/1
12
20/2
13
9/1

Wastewater samples are accepted Mon-Thurs 8:00-3:00 and must be received within 6 hours of collection. If more than 2 hours elapses between collection and receipt, the samples must be refrigerated or stored in a cooler with blue ice. If bottle contains preservative, take caution not to overfill; otherwise, simply fill bottles with representative sample, leaving a 1-inch air space for laboratory homogenization. It's important that this form is properly completed by the sampler, if you have questions feel free to contact the lab.

<i>KB-Setlers</i>	<i>"</i>	<i>"</i>	<i>10:15am</i>	<i>"</i>	<i>FC</i>
FIELD NOTES:	<i>"</i>	<i>"</i>	<i>"</i>	<i>"</i>	<i>ENTERO</i>

5441

2
16/4

received @ 5.0° C

Tracking Information

Relinquished By:	Date	Time	Received By:	Date	Time
<i>Nicole Forbes</i>	<i>07/27/17</i>		<i>Jana</i>	<i>7/27/17</i>	<i>1040</i>



R&M ENGINEERING-KETCHIKAN, INC.
ENGINEERS GEOLOGISTS SURVEYORS

355 CARLAINNA LAKE ROAD, SUITE 200, KETCHIKAN, ALASKA 99901
 PHONE (907) 225-7917 FAX (907) 225-3441 EMAIL: RNMMain@mketchikan.com

ADEC Division of Water
 Attn: Gretchen Pikul
 410 Willoughby Ave
 Jumeau, AK 99811

Ketchikan BEACH

Sampler: Nicole Forbes
 Date: 7/27/2017
 Time: 0815-1015
 Matrix: Marine water
 Type: Grab

LAB RECEIVING

Date: 7/27/2017
 Time: 1040

LAB REPORTING

Date: 7/31/2017
 Time: 1845

ANALYST: JML

Lab #	Sample Name	Analysis	Date Tested	Time Tested	Results	Units	MRL	Method
23436	KB-Knudson	FC	7/27/2017	1420	9	cfu / 100 ml	1.0	9222D
		ENTERO	7/27/2017	1500	12.2	MPN / 100 ml	1.0	D6503
23437	KB-Beacon Hill	FC	7/27/2017	1420	6	cfu / 100 ml	1.0	9222D
		ENTERO	7/27/2017	1500	19.3	MPN / 100 ml	1.0	D6503
23438	KB- S Pt Higgins	FC	7/27/2017	1420	16	cfu / 100 ml	1.0	9222D
		ENTERO	7/27/2017	1500	7.4	MPN / 100 ml	1.0	D6503
23439	KB-Shull	FC	7/27/2017	1420	12	cfu / 100 ml	1.0	9222D
		ENTERO	7/27/2017	1500	27.5	MPN / 100 ml	1.0	D6503
23440	KB-Sunset	FC	7/27/2017	1420	13	cfu / 100 ml	1.0	9222D
		ENTERO	7/27/2017	1500	10.9	MPN / 100 ml	1.0	D6503
23441	KB-Settlers	FC	7/27/2017	1420	2	cfu / 100 ml	1.0	9222D
		ENTERO	7/27/2017	1500	23.8	MPN / 100 ml	1.0	D6503



R&M ENGINEERING-KETCHIKAN, INC.
 355 Carlanna Lake Road, Ketchikan AK 99901
 phone 907-2257917 / fax 907-225-3441

Chain of Custody	
Report Attention: <u>Nicole Forbes</u>	Phone Number: <u>907-465-5023</u>
Company Name: <u>DEC Div of Water</u>	Fax Number:
Address: <u>410 Willoughby Avenue</u>	Sampler Name (Print): <u>Nicole Forbes</u>
City, State, Zip: <u>Juneau, AK 99811</u>	Sampler Signature: <u>Nicole Forbes</u>

Sample Information					
Sample Location	Sample Matrix (waste, drinking, storm)	Date	Time	Grab/Comp	Analysis Requested
<u>KB-KNUDSON</u>	<u>manure</u>	<u>7/31/17</u>	<u>10:52 am</u>	<u>grab</u>	<u>FC SM 9222 D</u>
<u>"</u>	<u>"</u>	<u>"</u>	<u>"</u>	<u>"</u>	<u>Entero 06503-99</u>
<u>KB-Beacon</u>	<u>"</u>	<u>"</u>	<u>11:12 am</u>	<u>"</u>	<u>FC</u>
<u>"</u>	<u>"</u>	<u>"</u>	<u>"</u>	<u>"</u>	<u>Entero</u>
<u>KB-SP Higgins</u>	<u>"</u>	<u>"</u>	<u>11:37 am</u>	<u>"</u>	<u>FC</u>
<u>"</u>	<u>"</u>	<u>"</u>	<u>"</u>	<u>"</u>	<u>Entero</u>
<u>KB-Shull</u>	<u>"</u>	<u>"</u>	<u>11:55 am</u>	<u>"</u>	<u>FC</u>
<u>"</u>	<u>"</u>	<u>"</u>	<u>"</u>	<u>"</u>	<u>Entero</u>
<u>KB-Sunset</u>	<u>"</u>	<u>"</u>	<u>12:13 pm</u>	<u>"</u>	<u>FC</u>
<u>"</u>	<u>"</u>	<u>"</u>	<u>"</u>	<u>"</u>	<u>Entero</u>

Wastewater samples are accepted Mon-Thurs 8:00-3:00 and must be received within 6 hours of collection. If more than 2 hours elapses between collection and receipt, the samples must be refrigerated or stored in a cooler with blue ice. If bottle contains preservative, take caution not to overfill; otherwise, simply fill bottles with representative sample, leaving a 1-inch air space for laboratory homogenization. It's important that this form is properly completed by the sampler, if you have questions feel free to contact the lab.

KB-settler's " " 12:30 pm " FC
 " " " " Entero
 FIELD NOTES:

FC @ 1750
Entero @ 1830

Tracking Information					
Relinquished By:	Date	Time	Received By:	Date	Time
<u>Nicole Forbes</u>	<u>7/31/17</u>	<u>6:10 pm</u>	<u>[Signature]</u>	<u>7/31/17</u>	<u>1410</u>



R&M ENGINEERING-KETCHIKAN, INC.
ENGINEERS GEOLOGISTS SURVEYORS

355 CARLANNA LAKE ROAD, SUITE 200, KETCHIKAN, ALASKA 99901
 PHONE (907) 225-7917 FAX (907) 225-3441 EMAIL: RNMIain@mketchikan.com

ADEC Division of Water
 Attn: Gretchen Pikul
 410 Willoughby Ave
 Jumeau, AK 99811

Ketchikan BEACH

Sampler: Nicole Forbes
 Date: 7/31/2017
 Time: 1052-1230
 Matrix: Marine water
 Type: Grab

LAB RECEIVING

Date: 7/31/2017
 Time: 1410

LAB REPORTING

Date: 8/2/2017
 Time: 1000

ANALYST: JML

Lab #	Sample Name	Analysis	Date Tested	Time Tested	Results	Units	MRL	Method
23452	KB-Knudson	FC	7/31/2017	1750	167	cfu / 100 ml	1.0	9222D
		ENTERO	7/31/2017	1830	15.6	MPN / 100 ml	1.0	D6503
23453	KB-Beacon Hill	FC	7/31/2017	1750	6	cfu / 100 ml	1.0	9222D
		ENTERO	7/31/2017	1830	26.6	MPN / 100 ml	1.0	D6503
23454	KB- S Pt Higgins	FC	7/31/2017	1750	<1	cfu / 100 ml	1.0	9222D
		ENTERO	7/31/2017	1830	13.1	MPN / 100 ml	1.0	D6503
23455	* KB-Shull/Refuge	FC	7/31/2017	1750	6	cfu / 100 ml	1.0	9222D
		ENTERO	7/31/2017	1830	20.6	MPN / 100 ml	1.0	D6503
23456	KB-Sunset	FC	7/31/2017	1750	41	cfu / 100 ml	1.0	9222D
		ENTERO	7/31/2017	1830	34.1	MPN / 100 ml	1.0	D6503
23457	KB-Settlers	FC	7/31/2017	1750	8	cfu / 100 ml	1.0	9222D
		ENTERO	7/31/2017	1830	46.4	MPN / 100 ml	1.0	D6503

**Paperwork did not fully match sample bottle labels. "KB-Shull" was listed on the custody form but there were no bottles labeled "Shull". There were however, 2 bottles labeled "Refuge". The sample times from the bottles labeled "Refuge" matched the sample times for "Shull" samples on the chain of custody form.*

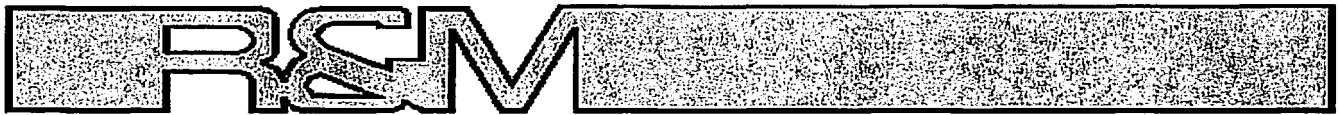

R&M ENGINEERING-KETCHIKAN, INC.
 355 Carlanna Lake Road, Ketchikan AK 99901
 phone 907-2257917 / fax 907-225-3441

Chain of Custody

Report Attention: Gretchen Pitkul, Forbes	Phone Number: 907 465 5023
Company Name: DEC Division Water	Fax Number:
Address: 410 Willoughby Ave.	Sampler Name (Print): Tony Gallegos
City, State, Zip Juneau AK 99811	Sampler Signature: <i>[Signature]</i>

Sample Information

Sample Location	Sample Matrix <small>(waste, drinking, storm)</small>	Date	Time	Grab/Comp	Analysis Requested
KB-Rotary	marine	8/1/17	12:22	grab	FCSM 9222D
KB-Rotary	"	"	12:22	"	Enterco D6503-99
KB-Seaport	"	"	12:41	"	FC
KB-Seaport	"	"	12:40	"	Enterco
KB-Thomas Basin	"	"	1:12	"	FC
KB-Thomas Basin	"	"	1:17	"	Enterco
KB-Mt. Point	"	11:20	1:12	12:41 pm	FC
KB-Mt. Point	"	11:20	1:12	12:41 pm	Enterco
KB-Refuge Cove	"	"	1:46	"	FC
KB-Refuge Cove	"	"	1:46	"	Enterco

Wastewater samples are accepted Mon-Thurs 8:00-3:00 and must be received within 6 hours of collection. If more than 2 hours elapses between collection and receipt, the samples must be refrigerated or stored in a cooler with blue ice. If bottle contains preservative, take caution not to overfill; otherwise, simply fill bottles with representative sample, leaving a 1-inch air space for laboratory homogenization. It's important that this form is properly completed by the sampler, if you have questions feel free to contact the lab.

FIELD NOTES:

Meta Mulder Intern assisted

Tracking Information

Relinquished By:	Date	Time	Received By:	Date	Time
<i>[Signature]</i>	8/1/17	2:18 pm	<i>[Signature]</i>	8/1/17	1418
			Temp = 5.5°C		



R&M ENGINEERING-KETCHIKAN, INC.
ENGINEERS GEOLOGISTS SURVEYORS

355 CARLAINNA LAKE ROAD, SUITE 200, KETCHIKAN, ALASKA 99901
 PHONE (907) 225-7917 FAX (907) 225-3441 EMAIL: RNMMain@mketchikan.com

ADEC Division of Water
 Attn: Gretchen Pikul
 410 Willoughby Ave
 Jumeau, AK 99811

Ketchikan BEACH

Sampler: Tony Gallegos
 Date: 8/1/2017
 Time: 1222-1346
 Matrix: Marine water
 Type: Grab

LAB RECEIVING

Date: 8/1/2017
 Time: 1418

LAB REPORTING

Date: 8/3/2017
 Time: 1030

ANALYST: JML

Lab #	Sample Name	Analysis	Date Tested	Time Tested	Results	Units	MRL	Method
23462	KB-Rotary	FC	8/1/2017	1600	9	cfu / 100 ml	1.0	9222D
		ENTERO	8/1/2017	1625	47.4	MPN / 100 ml	1.0	D6503
23463	KB-Seaport	FC	8/1/2017	1600	4	cfu / 100 ml	1.0	9222D
		ENTERO	8/1/2017	1625	3.1	MPN / 100 ml	1.0	D6503
23464	KB-Thomas Basin	FC	8/1/2017	1600	7	cfu / 100 ml	1.0	9222D
		ENTERO	8/1/2017	1625	3.0	MPN / 100 ml	1.0	D6503
23465	KB-Mt Point	FC	8/1/2017	1600	7	cfu / 100 ml	1.0	9222D
		ENTERO	8/1/2017	1625	26.6	MPN / 100 ml	1.0	D6503
23466	KB-Refuge	FC	8/1/2017	1600	21	cfu / 100 ml	1.0	9222D
		ENTERO	8/1/2017	1625	7.4	MPN / 100 ml	1.0	D6503



R&M ENGINEERING-KETCHIKAN, INC.
 355 Carlanna Lake Road, Ketchikan AK 99901
 phone 907-2257917 / fax 907-225-3441

Chain of Custody

Report Attention: (Jretchen Piku)	Phone Number: 907-465-5023
Company Name: DEC Div of Water	Fax Number:
Address: 410 Willoughby Avenue	Sampler Name (Print): Nicole Forbes
City, State, Zip Juneau, AK 99801	Sampler Signature: Nicole Forbes

Sample Information

Sample Location	Sample Matrix (waste, drinking, storm)	Date	Time	Grab/Comp	Analysis Requested
KB - Rotary	marine	8/8/17	5:30am	grab	FC
"	"	"	"	"	Enteroc
KB - Thomas Basin	"	"	5:50am	"	FC
"	"	"	"	"	Enteroc
KB - Seaport	"	"	6:20am	"	FC
"	"	"	"	"	Enteroc
KB - Refuge	"	"	7:00am	"	FC
"	"	"	"	"	Enteroc
KB - Mtn Point	"	"	7:05am	"	FC
"	"	"	"	"	Enteroc

Wastewater samples are accepted Mon-Thurs 8:00-3:00 and must be received within 6 hours of collection. If more than 2 hours elapses between collection and receipt, the samples must be refrigerated or stored in a cooler with blue ice. If bottle contains preservative, take caution not to overfill; otherwise, simply fill bottles with representative sample, leaving a 1-inch air space for laboratory homogenization. It's important that this form is properly completed by the sampler, if you have questions feel free to contact the lab.

FIELD NOTES: receiving temp = 7.0° C

Tracking Information

Relinquished By:	Date	Time	Received By:	Date	Time
Nicole Forbes	8/8/17	10:00am	[Signature]	8/8/17	1015



R&M ENGINEERING-KETCHIKAN, INC.
ENGINEERS GEOLOGISTS SURVEYORS

355 CARLANNA LAKE ROAD, SUITE 200, KETCHIKAN, ALASKA 99901
 PHONE (907) 225-7917 FAX (907) 225-3441 EMAIL: RNMMain@mketchikan.com

ADEC Division of Water
 Attn: Gretchen Pikul
 410 Willoughby Ave
 Jumeau, AK 99811

Ketchikan BEACH

Sampler: Nicole Forbes
 Date: 8/8/2017
 Time: 0530-0705
 Matrix: Marine water
 Type: Grab

LAB RECEIVING

Date: 8/8/2017
 Time: 1015

LAB REPORTING

Date: 8/11/2017
 Time: 1100

ANALYST: JML

Lab #	Sample Name	Analysis	Date Tested	Time Tested	Results	Units	MRL	Method
23524	KB-Rotary	FC	8/8/2017	1545	27	cfu / 100 ml	1.0	9222D
		ENTERO	8/8/2017	1605	980.4	MPN / 100 ml	1.0	D6503
23525	KB-Thomas Basin	FC	8/8/2017	1545	42	cfu / 100 ml	1.0	9222D
		ENTERO	8/8/2017	1605	86.2	MPN / 100 ml	1.0	D6503
23526	KB-Seaport	FC	8/8/2017	1545	21	cfu / 100 ml	1.0	9222D
		ENTERO	8/8/2017	1605	204.6	MPN / 100 ml	1.0	D6503
23527	KB-Refuge	FC	8/8/2017	1545	8	cfu / 100 ml	1.0	9222D
		ENTERO	8/8/2017	1605	1299.7	MPN / 100 ml	1.0	D6503
23528	KB-Mt Point	FC	8/8/2017	1545	15	cfu / 100 ml	1.0	9222D
		ENTERO	8/8/2017	1605	157.8	MPN / 100 ml	1.0	D6503

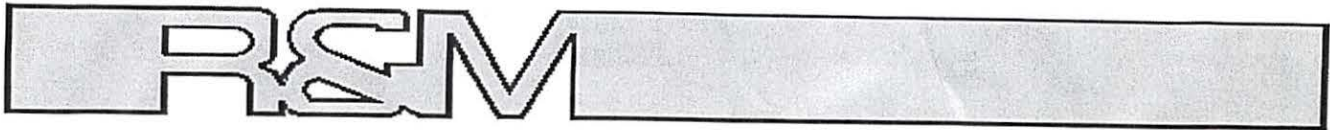

R&M ENGINEERING-KETCHIKAN, INC.
 355 Carlanna Lake Road, Ketchikan AK 99901
 phone 907-2257917 / fax 907-225-3441

Chain of Custody

Report Attention: Gretchen Pikel	Phone Number: 907-4105-5023
Company Name: DEC Division of Water	Fax Number:
Address: 476 Willoughby Avenue	Sampler Name (Print): Nicole Forbes
City, State, Zip Juneau AK 99817	Sampler Signature: <i>Nicole Forbes</i>

Sample Information

Sample Location	Sample Matrix <small>(waste, drinking, storm)</small>	Date	Time	Grab/Comp	Analysis Requested
KB-Knudson	marine	8/9/17	5:25am	grab	FC
"	"	"	"	"	Enteroto
KB-Beacon Hill	"	"	5:32am	"	FC
"	"	"	"	"	Enteroto
KB-SP Higgins	"	"	5:48am	"	FC
"	"	"	"	"	Enteroto
KB-Shull	"	"	6:05am	"	FC
"	"	"	"	"	Enteroto
KB-Sunset	"	"	6:20am	"	FC
"	"	"	"	"	Enteroto

Wastewater samples are accepted Mon-Thurs 8:00-3:00 and must be received within 6 hours of collection. If more than 2 hours elapses between collection and receipt, the samples must be refrigerated or stored in a cooler with blue ice. If bottle contains preservative, take caution not to overfill; otherwise, simply fill bottles with representative sample, leaving a 1-inch air space for laboratory homogenization. It's important that this form is properly completed by the sampler, if you have questions feel free to contact the lab.

KB-Settler's	"	"	7:17am	"	FC
FIELD NOTES:	"	"	7:17am	"	Enteroto

Tracking Information

Relinquished By:	Date	Time	Received By:	Date	Time
<i>Nicole Forbes</i>	8/9/17		<i>C. Hanna</i>	8/9/17	0925
			<i>@ 8.5°C</i>		



R&M ENGINEERING-KETCHIKAN, INC.
ENGINEERS GEOLOGISTS SURVEYORS

355 CARLANNA LAKE ROAD, SUITE 200, KETCHIKAN, ALASKA 99901
 PHONE (907) 225-7917 FAX (907) 225-3441 EMAIL: RNMMain@mketchikan.com

ADEC Division of Water
 Attn: Gretchen Pikul
 410 Willoughby Ave
 Jumeau, AK 99811

Ketchikan BEACH

Sampler: Nicole Forbes
 Date: 8/9/2017
 Time: 0525-0717
 Matrix: Marine water
 Type: Grab

LAB RECEIVING

Date: 8/9/2017
 Time: 925

LAB REPORTING

Date: 8/11/2017
 Time: 1115

ANALYST: JML

Lab #	Sample Name	Analysis	Date Tested	Time Tested	Results	Units	MRL	Method
23532	KB-Knudson	FC	8/9/2017	1115	98	cfu / 100 ml	1.0	9222D
		ENTERO	8/9/2017	1050	1986.3	MPN / 100 ml	1.0	D6503
23533	KB-Beacon Hill	FC	8/9/2017	1115	11	cfu / 100 ml	1.0	9222D
		ENTERO	8/9/2017	1050	579.4	MPN / 100 ml	1.0	D6503
23534	KB-S Pt Higgins	FC	8/9/2017	1115	7	cfu / 100 ml	1.0	9222D
		ENTERO	8/9/2017	1050	1,119.9	MPN / 100 ml	1.0	D6503
23535	KB-Shull	FC	8/9/2017	1115	4	cfu / 100 ml	1.0	9222D
		ENTERO	8/9/2017	1050	75.9	MPN / 100 ml	1.0	D6503
23536	KB-Sunset	FC	8/9/2017	1115	142	cfu / 100 ml	1.0	9222D
		ENTERO	8/9/2017	1050	248.1	MPN / 100 ml	1.0	D6503
23537	KB-Settlers	FC	8/9/2017	1115	3	cfu / 100 ml	1.0	9222D
		ENTERO	8/9/2017	1050	980.4	MPN / 100 ml	1.0	D6503

Human Fecal Quantification ID

Detection and quantification of the fecal associated Human gene biomarker by real-time quantitative Polymerase Chain Reaction (qPCR) DNA analytical technology

Submitter: DEC Division of Water
Date Received: August 10, 2017
Report Generated: August 30, 2017

DNQ: Detected Not Quantified

SM #	Sample ID	Analysis Requested	Marker Quantified (copies/100 ml)	DNA Analytical Results
SM-7H10048	KB-Knudson	Human Bacteroidetes ID: Dorei	1.38E+03	Detected
SM-7H10049	KB-Beacon Hill	Human Bacteroidetes ID: Dorei	1.60E+02	Detected
SM-7H10050	KB-SP Higgins	Human Bacteroidetes ID: Dorei	DNQ	Detected
SM-7H10051	KB-Shull	Human Bacteroidetes ID: Dorei	1.68E+02	Detected
SM-7H10052	KB-Sunset	Human Bacteroidetes ID: Dorei	DNQ	Detected
SM-7H10053	KB-Settlers	Human Bacteroidetes ID: Dorei	DNQ	Detected

Limitation of Damages – Repayment of Service Price

It is agreed that in the event of breach of any warranty or breach of contract, or negligence of Source Molecular Corporation, as well as its agents or representatives, the liability of the company shall be limited to the repayment, to the purchaser (submitter), of the individual analysis price paid by him/her to Source Molecular Corp. The company shall not be liable for any damages, either direct or consequential. Source Molecular Corp. provides analytical services on a PRIME CONTRACT BASIS ONLY. Terms are available upon request. The sample(s) cited in this report may be used for research purposes after an archiving period of 3 months from the date of this report. Research includes, but is not limited to internal validation studies and peer-reviewed research publications. Anonymity of the sample(s), including the exact geographic location will be maintained by assigning an arbitrary internal reference. These anonymous samples will only be grouped by state / province of origin for research purposes. The client must contact Source Molecular in writing within 10 days from the date of this report if he/she does not wish for their submitted sample(s) to be used for any type of future research.

Preliminary Interpretation of Human Fecal “Quantification” ID Results

Detection and quantification of the fecal associated Human gene biomarker by real-time quantitative Polymerase Chain Reaction (qPCR) DNA analytical technology

Submitter: DEC Division of Water
Date Received: August 10, 2017
Report Generated: August 30, 2017

Sample ID	INTERPRETATION	
	Concentration of Human Fecal Pollution in Sample	Comment
KB-Knudson	Low Concentration	Low levels of Human fecal biomarker(s)
KB-Beacon Hill	Low Concentration	Low levels of Human fecal biomarker(s)
KB-SP Higgins	Low Concentration	Low levels of Human fecal biomarker(s)
KB-Shull	Low Concentration	Low levels of Human fecal biomarker(s)
KB-Sunset	Low Concentration	Low levels of Human fecal biomarker(s)
KB-Settlers	Low Concentration	Low levels of Human fecal biomarker(s)

Laboratory Comments

Submitter: DEC Division of Water

Report Generated: August 30, 2017

Non-Detect Results

In sample(s) classified as non-detect, the host-associated fecal gene biomarker(s) was either not detected in test replicates, one replicate was detected at a cycle threshold greater than 35 and the other was not, or one replicate was detected at a cycle threshold less than 35 and the other was not after repeated analysis.

Detected Results

In sample(s) classified as detected, the host-associated fecal gene biomarker(s) was detected in both test replicates suggesting that the host's fecal contamination is present in the sample(s). Copy number measurements reported are relative, not absolute, quantification.

Detected Not Quantified (DNQ) Results

In sample(s) classified as Detected Not Quantified (DNQ), the host-associated fecal biomarker was detected in both test replicates but in quantities below the limit of quantification. This result indicates that fecal indicators associated with the respective host was present in the sample(s) but in low concentrations.

Fecal Reference Samples

The client is encouraged to submit fecal samples from suspected sources in the surrounding area in order to gain a better understanding of the concentration of the host-associated biomarker with the regional population. A more precise interpretation would be available to the client with the submittal of such baseline samples.

Result Interpretations

Quantitative results are reported along with interpretations. Interpretations are given as "non-detect", "low concentration", "moderate concentration", or "high concentration" based on the concentration of the genetic markers found in the sample(s).

The presence of the biomarker does not signify the presence or absence of that form of fecal pollution conclusively. Only repeated sampling will enable you to draw more definitive conclusions as to the contributor(s) of fecal pollution.

Additional Testing

A portion of all samples has been frozen and will be archived for 3 months. The client is encouraged to perform additional tests on the sample(s) for other hosts suspected of contributing to the fecal contamination. A list of available tests can be found at sourcemolecular.com/tests

DNA Analytical Method Explanation

Water Samples: Each submitted water sample is filtered through 0.45 micron membrane filter(s). Each filter is placed in a separate, sterile 2ml disposable tube containing a unique mix of beads and lysis buffer. The sample is homogenized for 1min and the DNA extracted using the Generite DNA-EZ ST1 extraction kit (GeneRite, NJ), as per manufacturer's protocol. Deviations to these procedures may occur at the client's request.

Non-Water Samples: Each non-water sample submitted by the client is processed as per internal laboratory extraction procedures. An extracted DNA sample is proceed directly to PCR analysis. Details available upon request.

Amplifications to detect the target gene biomarker were run on an Applied Biosystems StepOnePlus real-time thermal cycler (Applied Biosystems, Foster City, CA) in a final reaction volume of 20ul sample extract, forward primer, reverse primer, probe and an optimized buffer. All assays are run in duplicate. Quantification is achieved by extrapolating target gene copy numbers from a standard curve generated from serial dilutions of known gene copy numbers.

For quality control purposes, a positive control and a negative control, were run alongside the sample(s) to ensure a properly functioning reaction and reveal any false negatives or false positives.

Human Bacteroidetes ID™ Species: *B. dorei*

The **Human Bacteroidetes ID™ Species: *B. dorei*** service targets the species *Bacteroides dorei*. *B. dorei* is an anaerobe that is frequently shed from the gastrointestinal tract and isolated from human feces worldwide. It is a newly discovered species that is widely distributed in the USA.^{1,2} The human-associated marker DNA sequence is located on the 16S rRNA gene of *B. dorei*.³ The marker is the microbial source tracking (MST) marker of choice for detecting human fecal pollution due to its exceptional sensitivity and specificity. Internal validations have been conducted on hundreds of sewage, septage, human and animal host fecal samples collected from throughout the U.S and archived in the Source Molecular fecal bank. The marker has also been evaluated in both inland and coastal waters. A recent, comprehensive, multi-laboratory MST method evaluation study, exploring the performance of current MST methods, concluded the *B. dorei* qPCR assay to be the top performing human-associated assay amongst those tested. The success and consistency of this marker in numerous studies around the world^{1,3,4} makes the **Human Bacteroidetes ID™ Species: *B. dorei*** service the primary service for identifying human fecal pollution at Source Molecular.

Fecal *Bacteroidetes* are considered for several reasons an interesting alternative to more traditional indicator organisms such as *E. coli* and *Enterococci*.⁵ Since they are strict anaerobes, they are indicative of recent fecal contamination when found in water systems. This is a particularly strong reference point when trying to determine recent outbreaks in fecal pollution. They are also more abundant in feces of warm-blooded animals than *E. coli* and *Enterococci*.

The Human Bacteroidetes ID™ service is designed around the principle that fecal *Bacteroidetes* are found in large quantities in feces of warm-blooded animals.^{3,5,6,7,8} Furthermore, certain strains of *Bacteroidetes* have been found to be associated with humans.^{3,6} As such, these bacterial strains can be used as indicators of human fecal contamination.

Accuracy of the results is possible because the method amplifies DNA into a large number of small copies of the gene biomarker of interest. This is accomplished with small pieces of DNA called primers that are complementary and specific to the unique *B. dorei* DNA sequence. Through a heating process called thermal cycling, the double stranded DNA is denatured, hybridized to the complementary primers and amplified to create many copies of the DNA fragment desired. If the primers are successful in finding a site on the DNA fragment that is specific to the *B. dorei* DNA sequence, then billions of copies of the DNA fragment will be available and detected in real-time. The accumulation of DNA product is plotted as an amplification curve by the qPCR software. The absence of an amplification curve indicates that the *B. dorei* gene biomarker is not detected in the water sample because it is either not present or present at concentrations below the analytical detection limit.

To strengthen the validity of the results, additional tests targeting other high-ranking, human-associated *Bacteroidetes* species should be performed, such as **Human Bacteroidetes ID™ Species: *B. stercoris***, **Human Bacteroidetes ID™ Species: *B. fragilis***, and **Human Bacteroidetes ID™ Species: *B. thetaiotaomicron***.

¹Boehm, A., Fuhrman, J., Mrse, R., Grant, S. **Tiered approach for identification of a human fecal pollution source at a recreational beach: case study at Avalon Bay, Catalina Island, California.** Environ Sci Technol. 2003 37: 673–680.

²Bakir, M., Sakamoto, M., Kitahara, M., Matsumoto, M., Benno, Y. **Bacteroides dorei sp. nov., isolated from human faeces.** Int. J. Syst. Evol. Microbiol. 2006 56: 1639–1641.

³Bernhard, A., Field, K. **A PCR assay to discriminate human and ruminant feces on the basis of host differences in Bacteroides-Prevotella genes encoding 16S rRNA.** Appl. Environ. Microbiol. 2000b 66: 4571–4574.

⁴Ahmed, w., Masters, N., Toze, S. **Consistency in the host specificity and host sensitivity of the Bacteroides HF183 marker for sewage pollution tracking.** Lett. Appl. Microbiol. 2012 55: 283–289.

⁵Scott, T., Rose, J., Jenkins, T., Farrah, S., Lukasik, J. **Microbial Source Tracking: Current Methodology and Future Directions.** Appl. Environ. Microbiol. 2002 68: 5796–5803.

⁶Bernhard, A., Field, K. **Identification of nonpoint sources of fecal pollution in coastal waters by using host-specific 16S ribosomal DNA genetic markers from fecal anaerobes.** Appl. Environ. Microbiol. 2000a 66: 1587–1594.

Human Fecal Quantification ID

Detection and quantification of the fecal associated Human gene biomarker by real-time quantitative Polymerase Chain Reaction (qPCR) DNA analytical technology

Submitter: DEC Division of Water
Date Received: August 9, 2017
Report Generated: August 30, 2017

DNQ: Detected Not Quantified

SM #	Sample ID	Analysis Requested	Marker Quantified (copies/100 ml)	DNA Analytical Results
SM-7H09001	KB - Rotary	Human Bacteroidetes ID: Dorei	DNQ	Detected
SM-7H09002	KB - Thomas Basin	Human Bacteroidetes ID: Dorei	1.38E+02	Detected
SM-7H09003	KB - Seaport	Human Bacteroidetes ID: Dorei	1.18E+03	Detected
SM-7H09004	KB - Refuge	Human Bacteroidetes ID: Dorei	1.53E+02	Detected

Limitation of Damages – Repayment of Service Price

It is agreed that in the event of breach of any warranty or breach of contract, or negligence of Source Molecular Corporation, as well as its agents or representatives, the liability of the company shall be limited to the repayment, to the purchaser (submitter), of the individual analysis price paid by him/her to Source Molecular Corp. The company shall not be liable for any damages, either direct or consequential. Source Molecular Corp. provides analytical services on a PRIME CONTRACT BASIS ONLY. Terms are available upon request. The sample(s) cited in this report may be used for research purposes after an archiving period of 3 months from the date of this report. Research includes, but is not limited to internal validation studies and peer-reviewed research publications. Anonymity of the sample(s), including the exact geographic location will be maintained by assigning an arbitrary internal reference. These anonymous samples will only be grouped by state / province of origin for research purposes. The client must contact Source Molecular in writing within 10 days from the date of this report if he/she does not wish for their submitted sample(s) to be used for any type of future research.

Preliminary Interpretation of Human Fecal “Quantification” ID Results

Detection and quantification of the fecal associated Human gene biomarker by real-time quantitative Polymerase Chain Reaction (qPCR) DNA analytical technology

Submitter: DEC Division of Water
Date Received: August 9, 2017
Report Generated: August 30, 2017

Sample ID	INTERPRETATION	
	Concentration of Human Fecal Pollution in Sample	Comment
KB - Rotary	Low Concentration	Low levels of Human fecal biomarker(s)
KB - Thomas Basin	Low Concentration	Low levels of Human fecal biomarker(s)
KB - Seaport	Low Concentration	Low levels of Human fecal biomarker(s)
KB - Refuge	Low Concentration	Low levels of Human fecal biomarker(s)

Laboratory Comments

Submitter: DEC Division of Water

Report Generated: August 30, 2017

Non-Detect Results

In sample(s) classified as non-detect, the host-associated fecal gene biomarker(s) was either not detected in test replicates, one replicate was detected at a cycle threshold greater than 35 and the other was not, or one replicate was detected at a cycle threshold less than 35 and the other was not after repeated analysis.

Detected Results

In sample(s) classified as detected, the host-associated fecal gene biomarker(s) was detected in both test replicates suggesting that the host's fecal contamination is present in the sample(s). Copy number measurements reported are relative, not absolute, quantification.

Detected Not Quantified (DNQ) Results

In sample(s) classified as Detected Not Quantified (DNQ), the host-associated fecal biomarker was detected in both test replicates but in quantities below the limit of quantification. This result indicates that fecal indicators associated with the respective host was present in the sample(s) but in low concentrations.

Fecal Reference Samples

The client is encouraged to submit fecal samples from suspected sources in the surrounding area in order to gain a better understanding of the concentration of the host-associated biomarker with the regional population. A more precise interpretation would be available to the client with the submittal of such baseline samples.

Result Interpretations

Quantitative results are reported along with interpretations. Interpretations are given as "non-detect", "low concentration", "moderate concentration", or "high concentration" based on the concentration of the genetic markers found in the sample(s).

The presence of the biomarker does not signify the presence or absence of that form of fecal pollution conclusively. Only repeated sampling will enable you to draw more definitive conclusions as to the contributor(s) of fecal pollution.

Additional Testing

A portion of all samples has been frozen and will be archived for 3 months. The client is encouraged to perform additional tests on the sample(s) for other hosts suspected of contributing to the fecal contamination. A list of available tests can be found at sourcemolecular.com/tests

DNA Analytical Method Explanation

Water Samples: Each submitted water sample is filtered through 0.45 micron membrane filter(s). Each filter is placed in a separate, sterile 2ml disposable tube containing a unique mix of beads and lysis buffer. The sample is homogenized for 1min and the DNA extracted using the Generite DNA-EZ ST1 extraction kit (GeneRite, NJ), as per manufacturer's protocol. Deviations to these procedures may occur at the client's request.

Non-Water Samples: Each non-water sample submitted by the client is processed as per internal laboratory extraction procedures. An extracted DNA sample is proceed directly to PCR analysis. Details available upon request.

Amplifications to detect the target gene biomarker were run on an Applied Biosystems StepOnePlus real-time thermal cycler (Applied Biosystems, Foster City, CA) in a final reaction volume of 20ul sample extract, forward primer, reverse primer, probe and an optimized buffer. All assays are run in duplicate. Quantification is achieved by extrapolating target gene copy numbers from a standard curve generated from serial dilutions of known gene copy numbers.

For quality control purposes, a positive control and a negative control, were run alongside the sample(s) to ensure a properly functioning reaction and reveal any false negatives or false positives.

Human Bacteroidetes ID™ Species: *B. dorei*

The **Human Bacteroidetes ID™ Species: *B. dorei*** service targets the species *Bacteroides dorei*. *B. dorei* is an anaerobe that is frequently shed from the gastrointestinal tract and isolated from human feces worldwide. It is a newly discovered species that is widely distributed in the USA.^{1,2} The human-associated marker DNA sequence is located on the 16S rRNA gene of *B. dorei*.³ The marker is the microbial source tracking (MST) marker of choice for detecting human fecal pollution due to its exceptional sensitivity and specificity. Internal validations have been conducted on hundreds of sewage, septage, human and animal host fecal samples collected from throughout the U.S and archived in the Source Molecular fecal bank. The marker has also been evaluated in both inland and coastal waters. A recent, comprehensive, multi-laboratory MST method evaluation study, exploring the performance of current MST methods, concluded the *B. dorei* qPCR assay to be the top performing human-associated assay amongst those tested. The success and consistency of this marker in numerous studies around the world^{1,3,4} makes the **Human Bacteroidetes ID™ Species: *B. dorei*** service the primary service for identifying human fecal pollution at Source Molecular.

Fecal *Bacteroidetes* are considered for several reasons an interesting alternative to more traditional indicator organisms such as *E. coli* and *Enterococci*.⁵ Since they are strict anaerobes, they are indicative of recent fecal contamination when found in water systems. This is a particularly strong reference point when trying to determine recent outbreaks in fecal pollution. They are also more abundant in feces of warm-blooded animals than *E. coli* and *Enterococci*.

The Human Bacteroidetes ID™ service is designed around the principle that fecal *Bacteroidetes* are found in large quantities in feces of warm-blooded animals.^{3,5,6,7,8} Furthermore, certain strains of *Bacteroidetes* have been found to be associated with humans.^{3,6} As such, these bacterial strains can be used as indicators of human fecal contamination.

Accuracy of the results is possible because the method amplifies DNA into a large number of small copies of the gene biomarker of interest. This is accomplished with small pieces of DNA called primers that are complementary and specific to the unique *B. dorei* DNA sequence. Through a heating process called thermal cycling, the double stranded DNA is denatured, hybridized to the complementary primers and amplified to create many copies of the DNA fragment desired. If the primers are successful in finding a site on the DNA fragment that is specific to the *B. dorei* DNA sequence, then billions of copies of the DNA fragment will be available and detected in real-time. The accumulation of DNA product is plotted as an amplification curve by the qPCR software. The absence of an amplification curve indicates that the *B. dorei* gene biomarker is not detected in the water sample because it is either not present or present at concentrations below the analytical detection limit.

To strengthen the validity of the results, additional tests targeting other high-ranking, human-associated *Bacteroidetes* species should be performed, such as **Human Bacteroidetes ID™ Species: *B. stercoris***, **Human Bacteroidetes ID™ Species: *B. fragilis***, and **Human Bacteroidetes ID™ Species: *B. thetaiotaomicron***.

¹Boehm, A., Fuhrman, J., Mrse, R., Grant, S. **Tiered approach for identification of a human fecal pollution source at a recreational beach: case study at Avalon Bay, Catalina Island, California.** Environ Sci Technol. 2003 37: 673–680.

²Bakir, M., Sakamoto, M., Kitahara, M., Matsumoto, M., Benno, Y. **Bacteroides dorei sp. nov., isolated from human faeces.** Int. J. Syst. Evol. Microbiol. 2006 56: 1639–1641.

³Bernhard, A., Field, K. **A PCR assay to discriminate human and ruminant feces on the basis of host differences in Bacteroides-Prevotella genes encoding 16S rRNA.** Appl. Environ. Microbiol. 2000b 66: 4571–4574.

⁴Ahmed, w., Masters, N., Toze, S. **Consistency in the host specificity and host sensitivity of the Bacteroides HF183 marker for sewage pollution tracking.** Lett. Appl. Microbiol. 2012 55: 283–289.

⁵Scott, T., Rose, J., Jenkins, T., Farrah, S., Lukasik, J. **Microbial Source Tracking: Current Methodology and Future Directions.** Appl. Environ. Microbiol. 2002 68: 5796–5803.

⁶Bernhard, A., Field, K. **Identification of nonpoint sources of fecal pollution in coastal waters by using host-specific 16S ribosomal DNA genetic markers from fecal anaerobes.** Appl. Environ. Microbiol. 2000a 66: 1587–1594.

Dog Fecal Quantification ID

Detection and quantification of the fecal associated Dog gene biomarker by real-time quantitative Polymerase Chain Reaction (qPCR) DNA analytical technology

Submitter: DEC Division of Water
Date Received: August 9, 2017
Report Generated: August 30, 2017

DNQ: Detected Not Quantified

SM #	Sample ID	Analysis Requested	Marker Quantified (copies/100 ml)	DNA Analytical Results
SM-7H22001	KB - Rotary	Dog Bacteroidetes ID: Target 1	DNQ	Detected

Limitation of Damages – Repayment of Service Price

It is agreed that in the event of breach of any warranty or breach of contract, or negligence of Source Molecular Corporation, as well as its agents or representatives, the liability of the company shall be limited to the repayment, to the purchaser (submitter), of the individual analysis price paid by him/her to Source Molecular Corp. The company shall not be liable for any damages, either direct or consequential. Source Molecular Corp. provides analytical services on a PRIME CONTRACT BASIS ONLY. Terms are available upon request. The sample(s) cited in this report may be used for research purposes after an archiving period of 3 months from the date of this report. Research includes, but is not limited to internal validation studies and peer-reviewed research publications. Anonymity of the sample(s), including the exact geographic location will be maintained by assigning an arbitrary internal reference. These anonymous samples will only be grouped by state / province of origin for research purposes. The client must contact Source Molecular in writing within 10 days from the date of this report if he/she does not wish for their submitted sample(s) to be used for any type of future research.

Preliminary Interpretation of Dog Fecal "Quantification" ID Results

Detection and quantification of the fecal associated Dog gene biomarker by real-time quantitative Polymerase Chain Reaction (qPCR) DNA analytical technology

Submitter: DEC Division of Water
Date Received: August 9, 2017
Report Generated: August 30, 2017

Sample ID	INTERPRETATION	
	Concentration of Dog Fecal Pollution in Sample	Comment
KB - Rotary	Low Concentration	Low levels of Dog fecal biomarker(s)

Laboratory Comments

Submitter: DEC Division of Water

Report Generated: August 30, 2017

Non-Detect Results

In sample(s) classified as non-detect, the host-associated fecal gene biomarker(s) was either not detected in test replicates, one replicate was detected at a cycle threshold greater than 35 and the other was not, or one replicate was detected at a cycle threshold less than 35 and the other was not after repeated analysis.

Detected Results

In sample(s) classified as detected, the host-associated fecal gene biomarker(s) was detected in both test replicates suggesting that the host's fecal contamination is present in the sample(s). Copy number measurements reported are relative, not absolute, quantification.

Detected Not Quantified (DNQ) Results

In sample(s) classified as Detected Not Quantified (DNQ), the host-associated fecal biomarker was detected in both test replicates but in quantities below the limit of quantification. This result indicates that fecal indicators associated with the respective host was present in the sample(s) but in low concentrations.

Fecal Reference Samples

The client is encouraged to submit fecal samples from suspected sources in the surrounding area in order to gain a better understanding of the concentration of the host-associated biomarker with the regional population. A more precise interpretation would be available to the client with the submittal of such baseline samples.

Result Interpretations

Quantitative results are reported along with interpretations. Interpretations are given as "non-detect", "low concentration", "moderate concentration", or "high concentration" based on the concentration of the genetic markers found in the sample(s).

The presence of the biomarker does not signify the presence or absence of that form of fecal pollution conclusively. Only repeated sampling will enable you to draw more definitive conclusions as to the contributor(s) of fecal pollution.

Additional Testing

A portion of all samples has been frozen and will be archived for 3 months. The client is encouraged to perform additional tests on the sample(s) for other hosts suspected of contributing to the fecal contamination. A list of available tests can be found at sourcemolecular.com/tests

DNA Analytical Method Explanation

Water Samples: Each submitted water sample is filtered through 0.45 micron membrane filter(s). Each filter is placed in a separate, sterile 2ml disposable tube containing a unique mix of beads and lysis buffer. The sample is homogenized for 1min and the DNA extracted using the Generite DNA-EZ ST1 extraction kit (GeneRite, NJ), as per manufacturer's protocol. Deviations to these procedures may occur at the client's request.

Non-Water Samples: Each non-water sample submitted by the client is processed as per internal laboratory extraction procedures. An extracted DNA sample is proceed directly to PCR analysis. Details available upon request.

Amplifications to detect the target gene biomarker were run on an Applied Biosystems StepOnePlus real-time thermal cycler (Applied Biosystems, Foster City, CA) in a final reaction volume of 20ul sample extract, forward primer, reverse primer, probe and an optimized buffer. All assays are run in duplicate. Quantification is achieved by extrapolating target gene copy numbers from a standard curve generated from serial dilutions of known gene copy numbers.

For quality control purposes, a positive control and a negative control, were run alongside the sample(s) to ensure a properly functioning reaction and reveal any false negatives or false positives.

Theory Explanation of Dog Bacteroidetes “Quantification” ID™

The phylum *Bacteroidetes* is composed of three large groups of bacteria with the best-known category being *Bacteroidaceae*. This family of gram-negative bacteria is found primarily in the intestinal tracts and mucous membranes of warm-blooded animals and is sometimes considered pathogenic.

Comprising *Bacteroidaceae* are the genus *Bacteroides* and *Prevotella*. The latter genus was originally classified within the former (i.e. *Bacteroides*), but since the 1990's it has been classified in a separate genus because of new chemical and biochemical findings. *Bacteroides* and *Prevotella* are gram-negative, anaerobic, rod-shaped bacteria that inhabitant of the oral, respiratory, intestinal, and urogenital cavities of humans, animals, and insects. They are sometimes pathogenic.

Fecal *Bacteroidetes* are considered for several reasons an interesting alternative to more traditional indicator organisms such as *E. coli* and *Enterococci*.¹ Since they are strict anaerobes, they are indicative of recent fecal contamination when found in water systems. This is a particularly strong reference point when trying to determine recent outbreaks in fecal pollution. They are also more abundant in feces of warm-blooded animals than *E. coli* and *Enterococci*. Furthermore, these latter two organisms are facultative anaerobes and as such they can be problematic for monitoring purposes since it has been shown that they are able to proliferate in soil, sand and sediments.

The Dog Bacteroidetes ID™ service is designed around the principle that fecal *Bacteroidetes* are found in large quantities in feces of warm-blooded animals.^{2,3,4,5,6} Furthermore, certain categories of *Bacteroidetes* have been shown to be predominately detected in dog. Within these *Bacteroidetes*, certain strains of the *Bacteroides* and *Prevotella* genus have been found in dog.^{2,3,5,6} As such, these bacterial strains can be used as indicators of dog fecal contamination.

One of the advantages of the Dog Bacteroidetes ID™ service is that the entire water is sampled and filtered for fecal *Bacteroidetes*. As such, this method avoids the randomness effect of culturing and selecting bacterial isolates off a petri dish. This is a particular advantage for highly contaminated water systems with potential multiple sources of fecal contamination.

Accuracy of the results is possible because the method uses PCR DNA technology. PCR allows quantities of DNA to be amplified into large number of small copies of DNA sequences. This is accomplished with small pieces of DNA called primers that are complementary and specific to the genomes to be detected.

Through a heating process called thermal cycling, the double stranded DNA is denatured and inserted with complementary primers to create exact copies of the DNA fragment desired. This process is repeated rapidly many times ensuring an exponential progression in the number of copied DNA. If the primers are successful in finding a site on the DNA fragment that is specific to the genome to be studied, then billions of copies of the DNA fragment will be available and detected in real-time. The accumulation of DNA product is plotted as an amplification curve. The absence of an amplification curve would indicate that the dog *Bacteroidetes* gene biomarker is not present.

References

- ¹ Scott, Troy M., Rose, Joan B., Jenkins, Tracie M., Farrah, Samuel R., Lukasik, Jerzy **Microbial Source Tracking: Current Methodology and Future Directions.** Appl. Environ. Microbiol. (2002) 68: 5796-5803.
- ² Bernhard, A.E., and K.G. Field (2000a). **Identification of nonpoint sources of fecal pollution in coastal waters by using host-specific 16S ribosomal DNA genetic markers from fecal anaerobes.** Applied and Environmental Microbiology, 66: 1,587-1,594.
- ³ Bernhard, A.E., and K.G. Field (2000b). **A PCR assay to discriminate human and ruminant feces on the basis of host differences in Bacteroides-Prevotella genes encoding 16S rRNA.** Applied and Environmental Microbiology, 66: 4,571-4,574.
- ⁴ Kreader, C.A. (1995). **Design and evaluation of Bacteroides DNA probes for the specific detection of human fecal pollution.** Applied and Environmental Microbiology, 61: 1,171-1,179.
- ⁵ Fogarty, Lisa R., Voytek, Mary **A.Comparison of Bacteroides-Prevotella 16S rRNA Genetic Markers for Fecal Samples from Different Animal Species** Appl. Environ. Microbiol. 2005 71: 5999-6007.
- ⁶ Dick, Linda K., Bernhard, Anne E., Brodeur, Timothy J., Santo Domingo, Jorge W., Simpson, Joyce M., Walters, Sarah P., Field, Katharine G. **Host Distributions of Uncultivated Fecal Bacteroidales Bacteria Reveal Genetic Markers for Fecal Source Identification** Appl. Environ. Microbiol. 2005 71: 3184-3191.

Gull Fecal Quantification ID

Detection and quantification of the fecal associated Gull gene biomarker by real-time quantitative Polymerase Chain Reaction (qPCR) DNA analytical technology

Submitter: DEC Division of Water
Date Received: August 9, 2017
Report Generated: August 30, 2017

DNQ: Detected Not Quantified

SM #	Sample ID	Analysis Requested	Marker Quantified (copies/100 ml)	DNA Analytical Results
SM-7H22002	KB - Rotary	Gull Fecal ID	1.46E+02	Detected
SM-7H22003	KB - Thomas Basin	Gull Fecal ID	DNQ	Detected

Limitation of Damages – Repayment of Service Price

It is agreed that in the event of breach of any warranty or breach of contract, or negligence of Source Molecular Corporation, as well as its agents or representatives, the liability of the company shall be limited to the repayment, to the purchaser (submitter), of the individual analysis price paid by him/her to Source Molecular Corp. The company shall not be liable for any damages, either direct or consequential. Source Molecular Corp. provides analytical services on a PRIME CONTRACT BASIS ONLY. Terms are available upon request. The sample(s) cited in this report may be used for research purposes after an archiving period of 3 months from the date of this report. Research includes, but is not limited to internal validation studies and peer-reviewed research publications. Anonymity of the sample(s), including the exact geographic location will be maintained by assigning an arbitrary internal reference. These anonymous samples will only be grouped by state / province of origin for research purposes. The client must contact Source Molecular in writing within 10 days from the date of this report if he/she does not wish for their submitted sample(s) to be used for any type of future research.

Preliminary Interpretation of Gull Fecal "Quantification" ID Results

Detection and quantification of the fecal associated Gull gene biomarker by real-time quantitative Polymerase Chain Reaction (qPCR) DNA analytical technology

Submitter: DEC Division of Water
Date Received: August 9, 2017
Report Generated: August 30, 2017

Sample ID	INTERPRETATION	
	Concentration of Gull Fecal Pollution in Sample	Comment
KB - Rotary	Low Concentration	Low levels of Gull fecal biomarker(s)
KB - Thomas Basin	Low Concentration	Low levels of Gull fecal biomarker(s)

Laboratory Comments

Submitter: DEC Division of Water

Report Generated: August 30, 2017

Non-Detect Results

In sample(s) classified as non-detect, the host-associated fecal gene biomarker(s) was either not detected in test replicates, one replicate was detected at a cycle threshold greater than 35 and the other was not, or one replicate was detected at a cycle threshold less than 35 and the other was not after repeated analysis.

Detected Results

In sample(s) classified as detected, the host-associated fecal gene biomarker(s) was detected in both test replicates suggesting that the host's fecal contamination is present in the sample(s). Copy number measurements reported are relative, not absolute, quantification.

Detected Not Quantified (DNQ) Results

In sample(s) classified as Detected Not Quantified (DNQ), the host-associated fecal biomarker was detected in both test replicates but in quantities below the limit of quantification. This result indicates that fecal indicators associated with the respective host was present in the sample(s) but in low concentrations.

Fecal Reference Samples

The client is encouraged to submit fecal samples from suspected sources in the surrounding area in order to gain a better understanding of the concentration of the host-associated biomarker with the regional population. A more precise interpretation would be available to the client with the submittal of such baseline samples.

Result Interpretations

Quantitative results are reported along with interpretations. Interpretations are given as "non-detect", "low concentration", "moderate concentration", or "high concentration" based on the concentration of the genetic markers found in the sample(s).

The presence of the biomarker does not signify the presence or absence of that form of fecal pollution conclusively. Only repeated sampling will enable you to draw more definitive conclusions as to the contributor(s) of fecal pollution.

Additional Testing

A portion of all samples has been frozen and will be archived for 3 months. The client is encouraged to perform additional tests on the sample(s) for other hosts suspected of contributing to the fecal contamination. A list of available tests can be found at sourcemolecular.com/tests

DNA Analytical Method Explanation

Water Samples: Each submitted water sample is filtered through 0.45 micron membrane filter(s). Each filter is placed in a separate, sterile 2ml disposable tube containing a unique mix of beads and lysis buffer. The sample is homogenized for 1min and the DNA extracted using the Generite DNA-EZ ST1 extraction kit (GeneRite, NJ), as per manufacturer's protocol. Deviations to these procedures may occur at the client's request.

Non-Water Samples: Each non-water sample submitted by the client is processed as per internal laboratory extraction procedures. An extracted DNA sample is proceed directly to PCR analysis. Details available upon request.

Amplifications to detect the target gene biomarker were run on an Applied Biosystems StepOnePlus real-time thermal cycler (Applied Biosystems, Foster City, CA) in a final reaction volume of 20ul sample extract, forward primer, reverse primer, probe and an optimized buffer. All assays are run in duplicate. Quantification is achieved by extrapolating target gene copy numbers from a standard curve generated from serial dilutions of known gene copy numbers.

For quality control purposes, a positive control and a negative control, were run alongside the sample(s) to ensure a properly functioning reaction and reveal any false negatives or false positives.

C. marimammalium Gull Fecal “Quantification” ID™

C. marimammalium are shown to be ubiquitous in the gull gastrointestinal tract for multiple species of the gull genus *Larus* found throughout North America.¹

Classified as a novel genus and species in 2006, *C. marimammalium* is a Gram-positive, catalase-negative, facultatively anaerobic, coccus-shaped bacterium, related to, although distinct from, other catalase-negative genera which include *Enterococcus*, *Melissococcus*, *Tetragenococcus* and *Vagococcus*².

As a novel bacterium species, the pathogenesis of *C. marimammalium* is relatively unknown. However, there are increasing public health concerns regarding avian fecal contamination in the environment due to the potential spread of microbial avian pathogens to humans, domesticated animals, and human food sources¹. Studies have shown also that waterfowl carry human pathogens such as *Campylobacter spp*³, *Salmonella spp*⁴, and *E. coli*⁵, as well as being reservoirs of influenza viruses⁶.

The Gull Fecal ID™ service is designed around the principle that *C. marimammalium* is highly specific and sensitive to numerous gulls of the genus *Larus*¹. This *C. marimammalium* bacterium can be used as an indicator of gull fecal contamination. Use of real-time (quantitative) Polymerase Chain Reaction (qPCR) allows for the rapid amplification of the gene biomarker to demonstrate the presence of gull feces and allow for the real-time visualization of the target.

Accuracy of the results is possible because the method uses real-time (quantitative) PCR DNA technology. Real-time (quantitative) PCR allows small DNA sequences to be amplified exponentially and detected in real-time via fluorescent probes.

DNA amplification is accomplished with small pieces of DNA called primers that are specific to the genomes of interest. Through a heating process called thermal cycling, the double stranded DNA is denatured and inserted with complementary primers. The DNA is replicated to create exact copies of the desired DNA fragment (i.e. the gene biomarker). This process is repeated rapidly many times ensuring an exponential growth in the number of copied DNA.

If the primers are successful in finding a site on the DNA fragment that is specific to the genome to be studied, then billions of copies of the DNA fragment will be available for detection. With real-time (quantitative) PCR, the desired DNA fragments are also bound by fluorescent reporter probes. Consequently, the more copies of the desired DNA fragments that are made, the stronger the fluorescent signal, thus allowing for a straightforward detection and quantification of the targeted gene in real-time via the real-time PCR associated software. Nonetheless, as with all analytical tests, in order to strengthen the validity of the results, the Gull Fecal ID™ service should be combined with other DNA analytical services such as the *E. coli* ID™ service.

References

¹**Phylogenetic Diversity and Molecular Detection of Bacteria in Gull Feces** Lu, Jungrang, Santo Domingo, Jorge W., Lamendella, Regina, Edge, Thomas, Hill, Stephen; *Appl. Environ. Microbiol.*, **2008**, 74: 3969-3976.

²***Catellibacillus marimammalium* gen. nov., sp. nov., a novel gram-positive, catalase-negative, coccus-shaped bacterium from porpoise and grey seal** Lawson, P.A., Collins, M.D., Falsen, E., Foster, G.; *Int J Syst Evol Microbiol.* **2006**, 56: 429-432.

³**Prevalence of *Campylobacter jejuni*, *Campylobacter lari*, and *Campylobacter coli* in Different Ecological Guilds and Taxa of Migrating Birds** Waldenström, J., Broman, T., Carlsson, I., Hasselquist, D., Achterberg, R.P., Wagenaar, J.A., Olsen, B.; *Appl. Environ. Microbiol.*, **2002**, 68: 5911-5917.

⁴**Diversity of *Salmonella* Strains Isolated from the Aquatic Environment as Determined by Serotyping and Amplification of the Ribosomal DNA Spacer Regions** Julia Baudart, Karine Lemarchand, Anne Brisabois, and Philippe Lebaron.; *Appl. Environ. Microbiol.*; **2002**, 66: 1544-1552.

⁵**Detection and Characterization of Shiga-toxin Producing *E. coli* from Seagulls** Makino, S., Korbi, H., Asakura, H., Watarai, M., Shirahata, T., Ikeda, T., Takeshi, K., Tsukamoto, T.; *Epidemiol. Infect.*, **2000**, 125: 55-61.

⁶**Influenza in Migratory Birds and Evidence of Limited Intercontinental Virus Exchange** Krauss, S., Obert, C.A., Franks, J., Walker, D., Jones, K., Seiler, P., Niles, L., Pryor, S.P., Obenauer, J.C., Naeve, C.W., Widjaja, L., Webby, R.J., Webster, R.G.; *PLoS Pathog.*; **2007**, 3: 167.

Goose Fecal Quantification ID

Detection and quantification of the fecal associated Goose gene biomarker by real-time quantitative Polymerase Chain Reaction (qPCR) DNA analytical technology

Submitter: DEC Division of Water
Date Received: August 9, 2017
Report Generated: August 30, 2017

ND: Not Detected

SM #	Sample ID	Analysis Requested	Marker Quantified (copies/100 ml)	DNA Analytical Results
SM-7H09005	KB - Rotary	Goose Bacteroidetes ID: Target 1	ND	Not Detected

Limitation of Damages – Repayment of Service Price

It is agreed that in the event of breach of any warranty or breach of contract, or negligence of Source Molecular Corporation, as well as its agents or representatives, the liability of the company shall be limited to the repayment, to the purchaser (submitter), of the individual analysis price paid by him/her to Source Molecular Corp. The company shall not be liable for any damages, either direct or consequential. Source Molecular Corp. provides analytical services on a PRIME CONTRACT BASIS ONLY. Terms are available upon request. The sample(s) cited in this report may be used for research purposes after an archiving period of 3 months from the date of this report. Research includes, but is not limited to internal validation studies and peer-reviewed research publications. Anonymity of the sample(s), including the exact geographic location will be maintained by assigning an arbitrary internal reference. These anonymous samples will only be grouped by state / province of origin for research purposes. The client must contact Source Molecular in writing within 10 days from the date of this report if he/she does not wish for their submitted sample(s) to be used for any type of future research.

Preliminary Interpretation of Goose Fecal “Quantification” ID Results

Detection and quantification of the fecal associated Goose gene biomarker by real-time quantitative Polymerase Chain Reaction (qPCR) DNA analytical technology

Submitter: DEC Division of Water
Date Received: August 9, 2017
Report Generated: August 30, 2017

Sample ID	INTERPRETATION	
	Concentration of Goose Fecal Pollution in Sample	Comment
KB - Rotary	Not Detected	Goose fecal biomarker not detected

Laboratory Comments

Submitter: DEC Division of Water

Report Generated: August 30, 2017

Non-Detect Results

In sample(s) classified as non-detect, the host-associated fecal gene biomarker(s) was either not detected in test replicates, one replicate was detected at a cycle threshold greater than 35 and the other was not, or one replicate was detected at a cycle threshold less than 35 and the other was not after repeated analysis.

Detected Results

In sample(s) classified as detected, the host-associated fecal gene biomarker(s) was detected in both test replicates suggesting that the host's fecal contamination is present in the sample(s). Copy number measurements reported are relative, not absolute, quantification.

Detected Not Quantified (DNQ) Results

In sample(s) classified as Detected Not Quantified (DNQ), the host-associated fecal biomarker was detected in both test replicates but in quantities below the limit of quantification. This result indicates that fecal indicators associated with the respective host was present in the sample(s) but in low concentrations.

Fecal Reference Samples

The client is encouraged to submit fecal samples from suspected sources in the surrounding area in order to gain a better understanding of the concentration of the host-associated biomarker with the regional population. A more precise interpretation would be available to the client with the submittal of such baseline samples.

Result Interpretations

Quantitative results are reported along with interpretations. Interpretations are given as "non-detect", "low concentration", "moderate concentration", or "high concentration" based on the concentration of the genetic markers found in the sample(s).

The presence of the biomarker does not signify the presence or absence of that form of fecal pollution conclusively. Only repeated sampling will enable you to draw more definitive conclusions as to the contributor(s) of fecal pollution.

Additional Testing

A portion of all samples has been frozen and will be archived for 3 months. The client is encouraged to perform additional tests on the sample(s) for other hosts suspected of contributing to the fecal contamination. A list of available tests can be found at sourcemolecular.com/tests

DNA Analytical Method Explanation

Water Samples: Each submitted water sample is filtered through 0.45 micron membrane filter(s). Each filter is placed in a separate, sterile 2ml disposable tube containing a unique mix of beads and lysis buffer. The sample is homogenized for 1min and the DNA extracted using the Generite DNA-EZ ST1 extraction kit (GeneRite, NJ), as per manufacturer's protocol. Deviations to these procedures may occur at the client's request.

Non-Water Samples: Each non-water sample submitted by the client is processed as per internal laboratory extraction procedures. An extracted DNA sample is proceed directly to PCR analysis. Details available upon request.

Amplifications to detect the target gene biomarker were run on an Applied Biosystems StepOnePlus real-time thermal cycler (Applied Biosystems, Foster City, CA) in a final reaction volume of 20ul sample extract, forward primer, reverse primer, probe and an optimized buffer. All assays are run in duplicate. Quantification is achieved by extrapolating target gene copy numbers from a standard curve generated from serial dilutions of known gene copy numbers.

For quality control purposes, a positive control and a negative control, were run alongside the sample(s) to ensure a properly functioning reaction and reveal any false negatives or false positives.

Theory Explanation of Canada Goose Bacteroidetes “Quantification” ID™

The phylum *Bacteroidetes* is composed of three large groups of bacteria with the best-known category being *Bacteroidaceae*. This family of gram-negative bacteria is found primarily in the intestinal tracts and mucous membranes of warm-blooded animals and is sometimes considered pathogenic.

Comprising *Bacteroidaceae* are the genus *Bacteroides* and *Prevotella*. The latter genus was originally classified within the former (i.e. *Bacteroides*), but since the 1990's it has been classified in a separate genus because of new chemical and biochemical findings. *Bacteroides* and *Prevotella* are gram-negative, anaerobic, rod-shaped bacteria that inhabitant of the oral, respiratory, intestinal, and urogenital cavities of humans, animals, and insects. They are sometimes pathogenic.

Fecal *Bacteroidetes* are considered for several reasons an interesting alternative to more traditional indicator organisms such as *E. coli* and *Enterococci*.¹ Since they are strict anaerobes, they are indicative of recent fecal contamination when found in water systems. This is a particularly strong reference point when trying to determine recent outbreaks in fecal pollution. They are also more abundant in feces of warm-blooded animals than *E. coli* and *Enterococci*. Furthermore, these latter two organisms are facultative anaerobes and as such they can be problematic for monitoring purposes since it has been shown that they are able to proliferate in soil, sand and sediments.

The Canada Goose Bacteroidetes ID™ service is designed around the principle that fecal *Bacteroidetes* are found in large quantities in feces of warm-blooded animals.^{2,3,4,5,6} Furthermore, certain categories of *Bacteroidetes* have been shown to be predominately detected in Canada geese.⁷ Within these *Bacteroidetes*, certain strains of the *Bacteroides* and *Prevotella* genus have been found in Canada geese.⁷ As such, these bacterial strains can be used as indicators of Canada geese fecal contamination.

One of the advantages of the Canada Goose Bacteroidetes ID™ service is that the entire water is sampled and filtered for fecal *Bacteroidetes*. As such, this method avoids the randomness effect of culturing and selecting bacterial isolates off a petri dish. This is a particular advantage for highly contaminated water systems with potential multiple sources of fecal contamination.

Accuracy of the results is possible because the method uses PCR DNA technology. PCR allows quantities of DNA to be amplified into large number of small copies of DNA sequences. This is accomplished with small pieces of DNA called primers that are complementary and specific to the genomes to be detected.

Through a heating process called thermal cycling, the double stranded DNA is denatured and inserted with complementary primers to create exact copies of the DNA fragment desired. This process is repeated rapidly many times ensuring an exponential progression in the number of copied DNA. If the primers are successful in finding a site on the DNA fragment that is specific to the genome to be studied, then billions of copies of the DNA fragment will be available for detection in real-time.

References

- ¹ Scott, Troy M., Rose, Joan B., Jenkins, Tracie M., Farrah, Samuel R., Lukasik, Jerzy **Microbial Source Tracking: Current Methodology and Future Directions**. Appl. Environ. Microbiol. (2002) 68: 5796-5803.
- ² Bernhard, A.E., and K.G. Field (2000a). **Identification of nonpoint sources of fecal pollution in coastal waters by using host-specific 16S ribosomal DNA genetic markers from fecal anaerobes**. Applied and Environmental Microbiology, 66: 1,587-1,594.
- ³ Bernhard, A.E., and K.G. Field (2000b). **A PCR assay to discriminate human and ruminant feces on the basis of host differences in Bacteroides-Prevotella genes encoding 16S rRNA**. Applied and Environmental Microbiology, 66: 4,571-4,574.
- ⁴ Kreader, C.A. (1995). **Design and evaluation of Bacteroides DNA probes for the specific detection of human fecal pollution**. Applied and Environmental Microbiology, 61: 1,171-1,179.
- ⁵ Fogarty, Lisa R., Voytek, Mary **A.Comparison of Bacteroides-Prevotella 16S rRNA Genetic Markers for Fecal Samples from Different Animal Species** Appl. Environ. Microbiol. 2005 71: 5999-6007.
- ⁶ Dick, Linda K., Bernhard, Anne E., Brodeur, Timothy J., Santo Domingo, Jorge W., Simpson, Joyce M., Walters, Sarah P., Field, Katharine G. **Host distributions of uncultivated fecal Bacteroidales bacteria reveal genetic markers for fecal source identification** Appl. Environ. Microbiol. 2005 71: 3184-3191.

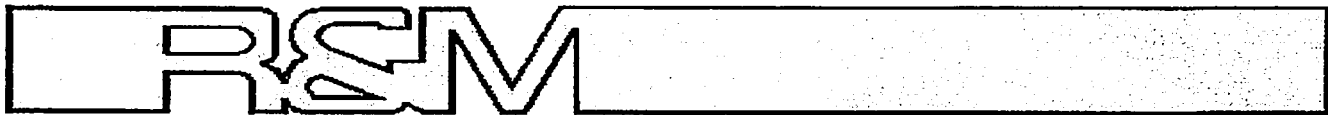

R&M ENGINEERING-KETCHIKAN, INC.
 355 Carlanna Lake Road, Ketchikan AK 99901
 phone 907-2257917 / fax 907-225-3441

Chain of Custody

Report Attention: <i>Gretchen Rikel</i>	Phone Number: <i>907 228 9445</i>
Company Name: <i>DEE Division west</i>	Fax Number:
Address: <i>410 Willoughby Ave</i>	Sampler Name (Print): <i>Tony Guallops</i>
City, State, Zip: <i>Tureau AK 99811</i>	Sampler Signature: <i>[Signature]</i>

Sample Information

PLEASE DO NOT WRITE ON BOTTLES/LIDS, USE PROVIDED REMOVABLE BLUE TAPE LABELS

Sample Location	Sample Matrix (waste, drinking, storm)	Date	Time ^{am}	Grab/Comp	Analysis Requested
<i>KB - Rotary</i>	<i>manure</i>	<i>8/14/17</i>	<i>11:15</i>	<i>grab</i>	<i>FC 922D</i>
<i>LB - Rotary</i>	<i>"</i>	<i>"</i>	<i>11:15</i>	<i>"</i>	<i>Enteroc De56399</i>
<i>KB - Mt. Point</i>	<i>"</i>	<i>"</i>	<i>11:08</i>	<i>"</i>	<i>FC</i>
<i>KB - Mt. Point</i>	<i>"</i>	<i>"</i>	<i>11:08</i>	<i>"</i>	<i>Enteroc</i>
<i>KB - Seaport</i>	<i>"</i>	<i>"</i>	<i>11:32</i>	<i>"</i>	<i>FC</i>
<i>KB - Seaport</i>	<i>"</i>	<i>"</i>	<i>11:32</i>	<i>"</i>	<i>Enteroc</i>
<i>KB - Thomas Basin</i>	<i>"</i>	<i>"</i>	<i>11:55</i>	<i>"</i>	<i>FC</i>
<i>KB - Thomas Basin</i>	<i>"</i>	<i>"</i>	<i>11:55</i>	<i>"</i>	<i>Enteroc</i>
<i>KB - Reduc Cove</i>	<i>"</i>	<i>"</i>	<i>12:35</i>	<i>"</i>	<i>FC</i>
<i>KB - Reduc Cove</i>	<i>"</i>	<i>"</i>	<i>12:35</i>	<i>"</i>	<i>Enteroc</i>

SAMPLING INSTRUCTIONS: Wastewater samples are accepted Mon-Thurs 8:00-3:00 and must be received within 6 hours of collection. If more than 2 hours elapses between collection and receipt, the samples must be stored under 10°C. When sampling, please leave a 1-inch air space for laboratory homogenization; please DO NOT fill to capacity.

This form MUST be completed by the sampler and the bottles labeled with the sample location AND facility name.

We need to be able to identify your samples from others based on these labels.

*Please

contact the lab if you have any questions*

FAILURE TO COMPLY WITH SAMPLING REQUIREMENTS MAY RESULT IN SAMPLE REJECTION

FIELD NOTES:

Tracking Information

Relinquished By:	Date	Time	Received By:	Date	Time
<i>[Signature]</i>	<i>8/14/17</i>	<i>12:55</i>	<i>[Signature]</i>	<i>8/14/17</i>	<i>13:55</i>



R&M ENGINEERING-KETCHIKAN, INC.
ENGINEERS GEOLOGISTS SURVEYORS

355 CARLANNA LAKE ROAD, SUITE 200, KETCHIKAN, ALASKA 99901
PHONE (907) 225-7917 FAX (907) 225-3441 EMAIL: RNMI@mketchikan.com

ADEC Division of Water
Attn: Gretchen Pikul
410 Willoughby Ave
Jumeau, AK 99811

Ketchikan BEACH

Sampler: Tony Gallegos
Date: 8/14/2017
Time: 1115-1235
Matrix: Marine water
Type: Grab

LAB RECEIVING

Date: 8/14/2017
Time: 1255

LAB REPORTING

Date: 8/15/2017
Time: 1545

ANALYST: JML

Lab #	Sample Name	Analysis	Date Tested	Time Tested	Results	Units	MRL	Method
23561	KB-Rotary	FC	8/14/2017	1450	21	cfu / 100 ml	1.0	9222D
		ENTERO	8/14/2017	1510	69.7	MPN / 100 ml	1.0	D6503
23562	KB-Mt. Point	FC	8/14/2017	1450	11	cfu / 100 ml	1.0	9222D
		ENTERO	8/14/2017	1510	313.0	MPN / 100 ml	1.0	D6503
23563	KB-Seaport	FC	8/14/2017	1450	37	cfu / 100 ml	1.0	9222D
		ENTERO	8/14/2017	1510	21.1	MPN / 100 ml	1.0	D6503
23564	KB-Thomas Basin	FC	8/14/2017	1450	36	cfu / 100 ml	1.0	9222D
		ENTERO	8/14/2017	1510	156.5	MPN / 100 ml	1.0	D6503
23565	KB-Refuge Cove	FC	8/14/2017	1450	6	cfu / 100 ml	1.0	9222D
		ENTERO	8/14/2017	1510	21.3	MPN / 100 ml	1.0	D6503

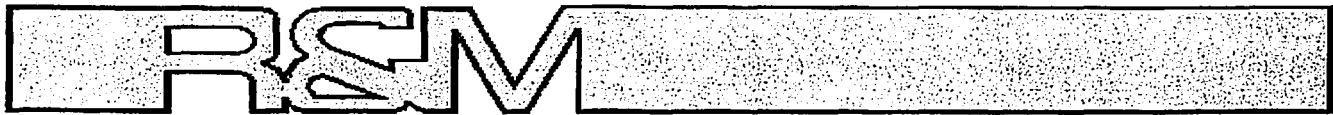

R&M ENGINEERING-KETCHIKAN, INC.
 355 Carlanna Lake Road, Ketchikan AK 99901
 phone 907-2257917 / fax 907-225-3441

Chain of Custody	
Report Attention: Gretchen Pitul, Forbes	Phone Number: 907 465 5023
Company Name: DEC Division Water	Fax Number:
Address: 410 Willoughby Ave.	Sampler Name (Print): Tony Gallegos
City, State, Zip Juneau AK 99811	Sampler Signature:

Sample Information					
Sample Location	Sample Matrix (waste, drinking, storm)	Date	Time	Grab/Comp	Analysis Requested
KB-Settlers	marine	8/15/17	9:15	grab	FCSM 9222D
KB-Settlers	"	8/15/17	9:15	"	Enterco D6503-99
KB-Knudson	"	8/15/17	9:28	"	FC
KB-Knudson	"	"	9:28	"	Enterco
KB-Beacon Hill	"	"	9:51	"	FC
KB-Beacon Hill	"	"	9:51	"	Enterco
KB-SP Higgins	"	"	10:15	"	FC
KB-SP Higgins	"	"	10:15	"	Enterco
KB-Shull	"	"	11:00	"	FC
KB-Shull	"	"	11:00	"	Enterco

Wastewater samples are accepted Mon-Thurs 8:00-3:00 and must be received within 6 hours of collection. If more than 2 hours elapses between collection and receipt, the samples must be refrigerated or stored in a cooler with blue ice. If bottle contains preservative, take caution not to overfill; otherwise, simply fill bottles with representative sample, leaving a 1-inch air space for laboratory homogenization. It's important that this form is properly completed by the

KB-Sunset	"	"	8:58	"	FC
KB-Sunset	"	"	8:58	"	Enterco

FIELD NOTES:

~~Alexa Mulder Intern assisted AG~~

Tracking Information					
Relinquished By:	Date	Time	Received By:	Date	Time
	8/15/17	11:43		8/15/17	1145
			@	4.0°C	



R&M ENGINEERING-KETCHIKAN, INC.
ENGINEERS GEOLOGISTS SURVEYORS

355 CARLANNA LAKE ROAD, SUITE 200, KETCHIKAN, ALASKA 99901
PHONE (907) 225-7917 FAX (907) 225-3441 EMAIL: RNMI@mketchikan.com

ADEC Division of Water
Attn: Gretchen Pikul
410 Willoughby Ave
Jumeau, AK 99811

Ketchikan BEACH

Sampler: Tony Gallegos
Date: 8/15/2017
Time: 0858-1100
Matrix: Marine water
Type: Grab

LAB RECEIVING

Date: 8/15/2017
Time: 1145

LAB REPORTING

Date: 8/16/2017
Time: 1610

ANALYST: JML

Lab #	Sample Name	Analysis	Date Tested	Time Tested	Results	Units	MRL	Method
23571	KB-Settlers	FC	8/15/2017	1520	9	cfu / 100 ml	1.0	9222D
		ENTERO	8/15/2017	1540	26.3	MPN / 100 ml	1.0	D6503
23572	KB-Knudson	FC	8/15/2017	1520	6	cfu / 100 ml	1.0	9222D
		ENTERO	8/15/2017	1540	26.9	MPN / 100 ml	1.0	D6503
23573	KB-Beacon Hill	FC	8/15/2017	1520	22	cfu / 100 ml	1.0	9222D
		ENTERO	8/15/2017	1540	16.6	MPN / 100 ml	1.0	D6503
23574	KB-S Pt Higgins	FC	8/15/2017	1520	161	cfu / 100 ml	1.0	9222D
		ENTERO	8/15/2017	1540	82.3	MPN / 100 ml	1.0	D6503
23575	KB-Shull	FC	8/15/2017	1520	27	cfu / 100 ml	1.0	9222D
		ENTERO	8/15/2017	1540	50.4	MPN / 100 ml	1.0	D6503
23576	KB-Sunset	FC	8/15/2017	1520	15	cfu / 100 ml	1.0	9222D
		ENTERO	8/15/2017	1540	22.5	MPN / 100 ml	1.0	D6503



R&M ENGINEERING-KETCHIKAN, INC.
 355 Carlanna Lake Road, Ketchikan AK 99901
 phone 907-2257917 / fax 907-225-3441

Chain of Custody	
Report Attention: Gretchen Pileau (WF/IG)	Phone Number: 907 228 9445
Company Name: DEC Division Water	Fax Number:
Address: 410 Willoughby Ave	Sampler Name (Print): Tony Gallegos
City, State, Zip: Juneau AK 99811	Sampler Signature: <i>[Signature]</i>

Sample Information

PLEASE DO NOT WRITE ON BOTTLES/LIDS, USE PROVIDED REMOVABLE BLUE TAPE LABELS

Sample Location	Sample Matrix (waste, drinking, storm)	Date	Time	Grab/Comp	Analysis Requested
KA Mt. Point	marine	8/22/17	9:00	Grab	FC
KB Mt. Point	"	"	9:00	"	Enteroc
KB Rotary	"	"	9:32	"	FC
KB Rotary	"	"	9:32	"	Enteroc
KB Seaport	"	"	9:47	"	FC
KB Seaport	"	"	9:47	"	Enteroc
KB Thomas Basin	"	"	10:08	"	FC
KB Thomas Basin	"	"	10:08	"	Enteroc
KB Redmye Cove	"	"	10:38	"	FC
KB Redmye Cove	"	"	10:38	"	Enteroc

SAMPLING INSTRUCTIONS: Wastewater samples are accepted Mon-Thurs 8:00-3:00 and must be received within 6 hours of collection. If more than 2 hours elapses between collection and receipt, the samples must be stored under 10°C. When sampling, please leave a 1-inch air space for laboratory homogenization; please DO NOT fill to capacity.

This form MUST be completed by the sampler and the bottles labeled with the sample location AND facility name. We need to be able to identify your samples from others based on these labels. *Please contact the lab if you have any questions*

FAILURE TO COMPLY WITH SAMPLING REQUIREMENTS MAY RESULT IN SAMPLE REJECTION

FIELD NOTES: heavy rain 24 hrs before sampling and during sampling event

if - receiving temp = 11° F

Tracking Information					
Relinquished By:	Date	Time	Received By:	Date	Time
Tony Gallegos	8/22/17	11:09	<i>[Signature]</i>	8/22/17	11:10



R&M ENGINEERING-KETCHIKAN, INC.
ENGINEERS GEOLOGISTS SURVEYORS

355 CARLANNA LAKE ROAD, SUITE 200, KETCHIKAN, ALASKA 99901
 PHONE (907) 225-7917 FAX (907) 225-3441 EMAIL: RNMMain@mketchikan.com

ADEC Division of Water
 Attn: Gretchen Pikul
 410 Willoughby Ave
 Jumeau, AK 99811

Ketchikan BEACH

Sampler: Tony Gallegos
 Date: 8/22/2017
 Time: 0900-1038
 Matrix: Marine water
 Type: Grab

LAB RECEIVING

Date: 8/22/2017
 Time: 1110

LAB REPORTING

Date: 8/23/2017
 Time: 1600

ANALYST: JML

Lab #	Sample Name	Analysis	Date Tested	Time Tested	Results	Units	MRL	Method
23597	KB-Mt Point	FC	8/22/2017	1440	32	cfu / 100 ml	1.0	9222D
		ENTERO	8/22/2017	1455	57.8	MPN / 100 ml	1.0	D6503
23598	KB-Rotary	FC	8/22/2017	1440	>200	cfu / 100 ml	1.0	9222D
		ENTERO	8/22/2017	1455	1119.9	MPN / 100 ml	1.0	D6503
23599	KB-Seaport	FC	8/22/2017	1440	CONFLUENT GROWTH	cfu / 100 ml	1.0	9222D
		ENTERO	8/22/2017	1455	250.0	MPN / 100 ml	1.0	D6503
23600	KB-Thomas Basin	FC	8/22/2017	1440	CONFLUENT GROWTH	cfu / 100 ml	1.0	9222D
		ENTERO	8/22/2017	1455	137.4	MPN / 100 ml	1.0	D6503
23601	KB-Refuge Cove	FC	8/22/2017	1440	69	cfu / 100 ml	1.0	9222D
		ENTERO	8/22/2017	1455	81.6	MPN / 100 ml	1.0	D6503

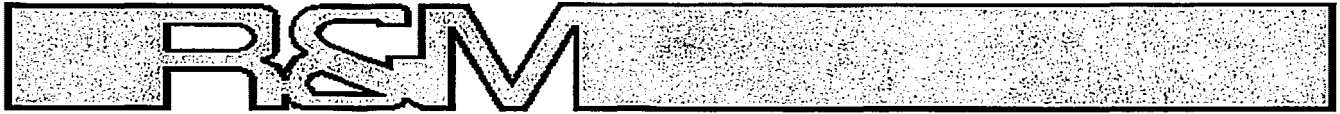

R&M ENGINEERING-KETCHIKAN, INC.
 355 Carlanna Lake Road, Ketchikan AK 99901
 phone 907-2257917 / fax 907-225-3441

Chain of Custody

Report Attention: <i>Gretchen Pikel</i>	Phone Number: <i>907-465-5023</i>
Company Name: <i>DEC Water</i>	Fax Number:
Address: <i>410 Willoughby Ave.</i>	Sampler Name (Print): <i>Tony Gallego</i>
City, State, Zip: <i>Juneau, AK 99811</i>	Sampler Signature: <i>[Signature]</i>

Sample Information

PLEASE DO NOT WRITE ON BOTTLES/LIDS, USE PROVIDED REMOVABLE BLUE TAPE LABELS

Sample Location	Sample Matrix (waste, drinking, storm)	Date	Time	Grab/Comp	Analysis Requested
<i>KB-Krudson</i>	<i>marine</i>	<i>8/23/17</i>	<i>8:58</i>	<i>Grab</i>	<i>FC SM 9227D</i>
<i>KB-Krudson</i>	<i>"</i>	<i>"</i>	<i>8:58</i>	<i>"</i>	<i>Enterics DL553-99</i>
<i>" Beacon Hill</i>	<i>"</i>	<i>"</i>	<i>9:22</i>	<i>"</i>	<i>FC</i>
<i>" Beacon Hill</i>	<i>"</i>	<i>"</i>	<i>9:22</i>	<i>"</i>	<i>Enterics</i>
<i>" Sp. Higgins</i>	<i>"</i>	<i>"</i>	<i>9:50</i>	<i>"</i>	<i>FC</i>
<i>" Sp. Higgins</i>	<i>"</i>	<i>"</i>	<i>9:50</i>	<i>"</i>	<i>Enterics</i>
<i>" Skull</i>	<i>"</i>	<i>"</i>	<i>10:17</i>	<i>"</i>	<i>FC</i>
<i>" Skull</i>	<i>"</i>	<i>"</i>	<i>10:17</i>	<i>"</i>	<i>Enterics</i>
<i>" Sunset</i>	<i>"</i>	<i>"</i>	<i>10:45</i>	<i>"</i>	<i>FC</i>
<i>" Sunset</i>	<i>"</i>	<i>"</i>	<i>10:45</i>	<i>"</i>	<i>Enterics</i>

SAMPLING INSTRUCTIONS: Wastewater samples are accepted Mon-Thurs 8:00-3:00 and must be received within 6 hours of collection. If more than 2 hours elapses between collection and receipt, the samples must be stored under 10°C. When sampling, please leave a 1-inch air space for laboratory homogenization; please DO NOT fill to capacity.

This form MUST be completed by the sampler and the bottles labeled with the sample location AND facility name. We need to be able to identify your samples from others based on these labels. *Please contact the lab if you have any questions*

FAILURE TO COMPLY WITH SAMPLING REQUIREMENTS MAY RESULT IN SAMPLE REJECTION

<i>" Settlers</i>	<i>"</i>	<i>"</i>	<i>8:30</i>	<i>"</i>	<i>FC</i>
<i>" Settlers</i>	<i>"</i>	<i>"</i>	<i>8:30</i>	<i>"</i>	<i>Enterics</i>

FIELD NOTES:

temp upon receipt = 2.5°C

Tracking Information

Relinquished By:	Date	Time	Received By:	Date	Time
<i>[Signature]</i>	<i>8/23/17</i>	<i>1106</i>	<i>[Signature]</i>	<i>8/23/17</i>	<i>1106</i>



R&M ENGINEERING-KETCHIKAN, INC.
ENGINEERS GEOLOGISTS SURVEYORS

355 CARLANNA LAKE ROAD, SUITE 200, KETCHIKAN, ALASKA 99901
 PHONE (907) 225-7917 FAX (907) 225-3441 EMAIL: RNMMain@mketchikan.com

ADEC Division of Water
 Attn: Gretchen Pikul
 410 Willoughby Ave
 Jumeau, AK 99811

Ketchikan BEACH

Sampler: Tony Gallegos
 Date: 8/23/2017
 Time: 0830-1045
 Matrix: Marine water
 Type: Grab

LAB RECEIVING

Date: 8/23/2017
 Time: 1106

LAB REPORTING

Date: 8/24/2017
 Time: 1645

ANALYST: JML

Lab #	Sample Name	Analysis	Date Tested	Time Tested	Results	Units	MRL	Method
23603	KB-Knudson	FC	8/23/2017	1535	>200	cfu / 100 ml	1.0	9222D
		ENTERO	8/23/2017	1520	488.4	MPN / 100 ml	1.0	D6503
23604	KB-Beacon Hill	FC	8/23/2017	1535	58	cfu / 100 ml	1.0	9222D
		ENTERO	8/23/2017	1520	101.7	MPN / 100 ml	1.0	D6503
23605	KB-S Pt Higgins	FC	8/23/2017	1535	37	cfu / 100 ml	1.0	9222D
		ENTERO	8/23/2017	1520	46.2	MPN / 100 ml	1.0	D6503
23606	KB-Shull	FC	8/23/2017	1535	33	cfu / 100 ml	1.0	9222D
		ENTERO	8/23/2017	1520	28.1	MPN / 100 ml	1.0	D6503
23607	KB-Sunset	FC	8/23/2017	1535	51	cfu / 100 ml	1.0	9222D
		ENTERO	8/23/2017	1520	33.7	MPN / 100 ml	1.0	D6503
23608	KB-Settlers	FC	8/23/2017	1535	29	cfu / 100 ml	1.0	9222D
		ENTERO	8/23/2017	1520	47.4	MPN / 100 ml	1.0	D6503

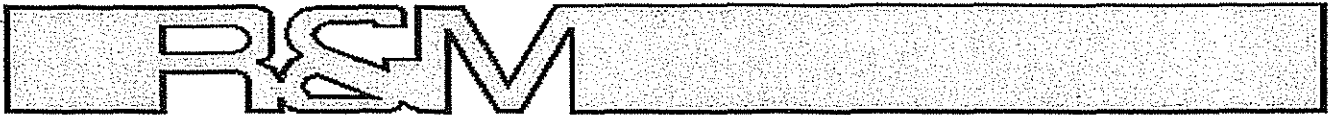

R&M ENGINEERING-KETCHIKAN, INC.
 355 Carlanna Lake Road, Ketchikan AK 99901
 phone 907-2257917 / fax 907-225-3441

Chain of Custody	
Report Attention: Gretchen Pikul & Nicole Forbes	Phone Number: 907-465-5023
Company Name: DEC Division of Water	Fax Number:
Address: 410 Willoughby Ave	Sampler Name (Print): Nicole Forbes
City, State, Zip Juneau, AK 99811	Sampler Signature: Nicole Forbes

Sample Information					
Sample Location	Sample Matrix (waste, drinking, storm)	Date	Time	Grab/Comp	Analysis Requested
3640 KB-Rotary	marine	08/17/17	10:40am	grab	FC SM 9222 D
"	"	"	"	"	Enterol 16503-99
3641 KB-Seaport	"	"	10:52am	"	FC
"	"	"	"	"	Enterol
3642 KB-Thomas Basin	"	"	11:10am	"	FC
"	"	"	"	"	Enterol
3643 KB-Refuge	"	"	11:42am	"	FC
"	"	"	"	"	Enterol
3644 KB-Mt Point	"	"	10:01am	"	FC
"	"	"	"	"	Enterol

Wastewater samples are accepted Mon-Thurs 8:00-3:00 and must be received within 6 hours of collection. If more than 2 hours elapses between collection and receipt, the samples must be refrigerated or stored in a cooler with blue ice. If bottle contains preservative, take caution not to overfill; otherwise, simply fill bottles with representative sample, leaving a 1-inch air space for laboratory homogenization. It's important that this form is properly completed by the sampler, if you have questions feel free to contact the lab.

FIELD NOTES: FC SET @ 11030
 ENTC SET @ 11050

PAGE 1 OF 2

Tracking Information					
Relinquished By:	Date	Time	Received By:	Date	Time
Nicole Forbes	08/17/17	1:30pm	Nicole	8/29	1:35pm

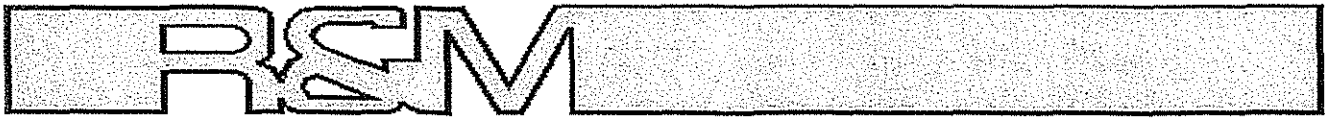

R&M ENGINEERING-KETCHIKAN, INC.
 355 Carlanna Lake Road, Ketchikan AK 99901
 phone 907-2257917 / fax 907-225-3441

Chain of Custody	
Report Attention: Gretchen Pikul & Nicole Forbes	Phone Number: 907-465 5023
Company Name: DEC Division of Water	Fax Number:
Address: 410 Willoughby Ave	Sampler Name (Print): Nicole Forbes
City, State, Zip: Juneau, AK 99811	Sampler Signature: Nicole Forbes

Sample Information					
PLEASE DO NOT WRITE ON BOTTLES/LIDS, USE PROVIDED REMOVABLE BLUE TAPE LABELS					
Sample Location	Sample Matrix (waste, drinking, storm)	Date	Time	Grab/Comp	Analysis Requested
KB-Sunset	Marine	08/29/17	11:50am	grab	FC sm 92220
"	"	"	"	"	Entero 06503-99
KB-Shull	"	"	12:15pm	"	FC
"	"	"	"	"	Entero
KB-SP Higgins	"	"	12:30pm	"	FC
"	"	"	"	"	Entero
KB-Beacon Hill	"	"	12:50pm	"	FC
"	"	"	"	"	Entero
KB-Knudson	"	"	1:07pm	"	FC
"	"	"	"	"	Entero

AB #
 3045
 3046
 3047
 3048
 3049

SAMPLING INSTRUCTIONS: Wastewater samples are accepted Mon-Thurs 8:00-3:00 and must be received within 6 hours of collection. If more than 2 hours elapses between collection and receipt, the samples must be stored under 10°C. When sampling, please leave a 1-inch air space for laboratory homogenization; please DO NOT fill to capacity. This form MUST be completed by the sampler and the bottles labeled with the sample location AND facility name. We need to be able to identify your samples from others based on these labels. *Please contact the lab if you have any questions*

FAILURE TO COMPLY WITH SAMPLING REQUIREMENTS MAY RESULT IN SAMPLE REJECTION

FIELD NOTES:

PAGE 2 OF 2

Tracking Information					
Relinquished By:	Date	Time	Received By:	Date	Time
Nicole Forbes	08/29/17	1:30pm	Nicole	8/29	1:35pm

**R&M ENGINEERING-KETCHIKAN, INC.****ENGINEERS GEOLOGISTS SURVEYORS**

355 CARLANNA LAKE ROAD, SUITE 200, KETCHIKAN, ALASKA 99901

PHONE (907) 225-7917 FAX (907) 225-3441 EMAIL: RNIMMain@rmketchikan.com

ADEC Division of Water
 Attn: Gretchen Pikul
 410 Willoughby Ave
 Jumeau, AK 99811

Ketchikan BEACH

Sampler: Nicole Forbes
 Date: 8/29/2017
 Time: 1040-1307
 Matrix: Marine water
 Type: Grab

LAB RECEIVING

Date: 8/29/2017
 Time: 1335

LAB REPORTING

Date: 8/31/2017
 Time: 1000

ANALYST: JML

Lab #	Sample Name	Analysis	Date Tested	Time Tested	Results	Units	MRL	Method
23640	KB-Rotary	FC	8/29/2017	1630	9	cfu / 100 ml	1.0	9222D
		ENTERO	8/29/2017	1650	69.3	MPN / 100 ml	1.0	D6503
23641	KB-Seaport	FC	8/29/2017	1630	41	cfu / 100 ml	1.0	9222D
		ENTERO	8/29/2017	1650	135.4	MPN / 100 ml	1.0	D6503
23642	KB-Thomas Basin	FC	8/29/2017	1630	<1	cfu / 100 ml	1.0	9222D
		ENTERO	8/29/2017	1650	14.5	MPN / 100 ml	1.0	D6503
23643	KB-Refuge	FC	8/29/2017	1630	7	cfu / 100 ml	1.0	9222D
		ENTERO	8/29/2017	1650	13.0	MPN / 100 ml	1.0	D6503
23644	KB-Mt Point	FC	8/29/2017	1630	2	cfu / 100 ml	1.0	9222D
		ENTERO	8/29/2017	1650	8.5	MPN / 100 ml	1.0	D6503
23645	KB-Sunset	FC	8/29/2017	1630	3	cfu / 100 ml	1.0	9222D
		ENTERO	8/29/2017	1650	<1	MPN / 100 ml	1.0	D6503
23646	KB-Shull	FC	8/29/2017	1630	16	cfu / 100 ml	1.0	9222D
		ENTERO	8/29/2017	1650	3.0	MPN / 100 ml	1.0	D6503
23647	KB-S Pt Higgins	FC	8/29/2017	1630	5	cfu / 100 ml	1.0	9222D
		ENTERO	8/29/2017	1650	24.3	MPN / 100 ml	1.0	D6503
23648	KB-Beacon Hill	FC	8/29/2017	1630	18	cfu / 100 ml	1.0	9222D
		ENTERO	8/29/2017	1650	7.2	MPN / 100 ml	1.0	D6503
23649	KB-Knudson	FC	8/29/2017	1630	2	cfu / 100 ml	1.0	9222D
		ENTERO	8/29/2017	1650	1.0	MPN / 100 ml	1.0	D6503



R&M ENGINEERING-KETCHIKAN, INC.
 355 Carlanna Lake Road, Ketchikan AK 99901
 phone 907-2257917 / fax 907-225-3441

Chain of Custody

Report Attention: <i>Gretchen Pikul</i>	Phone Number: <i>907-228-9445</i>
Company Name: <i>DFC Division of Water</i>	Fax Number:
Address: <i>410 Willoughby Ave</i>	Sampler Name (Print): <i>Nicole Forbes</i>
City, State, Zip <i>Juneau, AK, 99811</i>	Sampler Signature: <i>Nicole Forbes</i>

Sample Information

PLEASE DO NOT WRITE ON BOTTLES/LIDS, USE PROVIDED REMOVABLE BLUE TAPE LABELS

Sample Location	Sample Matrix <small>(waste, drinking, storm)</small>	Date	Time	Grab/Comp	Analysis Requested
<i>KB-Rotary</i>	<i>marine</i>	<i>9/13/17</i>	<i>9:38am</i>	<i>grab</i>	<i>FC 9222D</i>
<i>"</i>	<i>"</i>	<i>"</i>	<i>"</i>	<i>"</i>	<i>Enter 01650399</i>
<i>KB-Seaport</i>	<i>"</i>	<i>"</i>	<i>9:55am</i>	<i>"</i>	<i>FC</i>
<i>"</i>	<i>"</i>	<i>"</i>	<i>"</i>	<i>"</i>	<i>Entero</i>
<i>KB-Mtn Point</i>	<i>"</i>	<i>"</i>	<i>10:03am</i>	<i>"</i>	<i>FC</i>
<i>"</i>	<i>"</i>	<i>"</i>	<i>"</i>	<i>"</i>	<i>Entero</i>
<i>KB-Thomas Basin</i>	<i>"</i>	<i>"</i>	<i>10:20am</i>	<i>"</i>	<i>FC</i>
<i>"</i>	<i>"</i>	<i>"</i>	<i>"</i>	<i>"</i>	<i>Entero</i>
<i>KB-Refuge</i>	<i>"</i>	<i>"</i>	<i>10:50am</i>	<i>"</i>	<i>FC</i>
<i>"</i>	<i>"</i>	<i>"</i>	<i>"</i>	<i>"</i>	<i>Entero</i>

SAMPLING INSTRUCTIONS: Wastewater samples are accepted Mon-Thurs 8:00-3:00 and must be received within 6 hours of collection. If more than 2 hours elapses between collection and receipt, the samples must be stored under 10°C. When sampling, please leave a 1-inch air space for laboratory homogenization; please DO NOT fill to capacity.

This form MUST be completed by the sampler and the bottles labeled with the sample location AND facility name.

We need to be able to identify your samples from others based on these labels.

Please contact the lab if you have any questions

FAILURE TO COMPLY WITH SAMPLING REQUIREMENTS MAY RESULT IN SAMPLE REJECTION

FIELD NOTES: *Temp in = 5.5°C*

pg. 1 of 2

Tracking Information

Relinquished By:	Date	Time	Received By:	Date	Time
<i>Nicole Forbes</i>	<i>9/13/17</i>	<i>1415</i>	<i>J</i>	<i>9/13/17</i>	<i>1415</i>

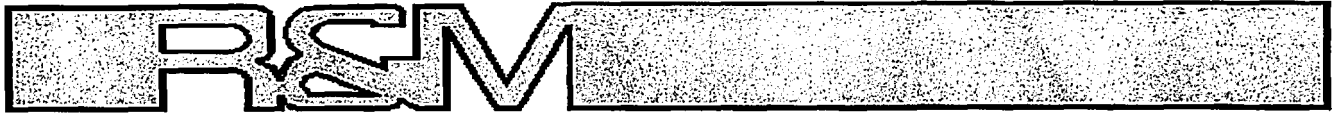

R&M ENGINEERING-KETCHIKAN, INC.
 355 Carlanna Lake Road, Ketchikan AK 99901
 phone 907-2257917 / fax 907-225-3441

Chain of Custody	
Report Attention: Gretchen Pikul	Phone Number: 907-228-9445
Company Name: DEC Division of Water	Fax Number:
Address: 410 Willoughby Ave	Sampler Name (Print): Nicole Forbes
City, State, Zip Juneau, AK, 99811	Sampler Signature: Nicole Forbes

Sample Information					
PLEASE DO NOT WRITE ON BOTTLES/LIDS, USE PROVIDED REMOVABLE BLUE TAPE LABELS					
Sample Location	Sample Matrix (waste, drinking, storm)	Date	Time	Grab/Comp	Analysis Requested
KB-Sunset	marine	9/13/17	11:15am	grab	FC 9222 D
"	"	"	"	"	Entero D6503-99
KB-Shull	"	"	11:32am	"	FC
"	"	"	"	"	Entero
KB-S Pt Higgins	"	"	11:55am	"	FC
"	"	"	"	"	Entero
KB- Beacon Hill	"	"	12:15pm	"	FC
"	"	"	"	"	Entero
KB- Knudson	"	"	12:35pm	"	FC
"	"	"	"	"	Entero

SAMPLING INSTRUCTIONS: Wastewater samples are accepted Mon-Thurs 8:00-3:00 and must be received within 6 hours of collection. If more than 2 hours elapses between collection and receipt, the samples must be stored under 10°C. When sampling, please leave a 1-inch air space for laboratory homogenization; please DO NOT fill to capacity.

This form MUST be completed by the sampler and the bottles labeled with the sample location AND facility name.

We need to be able to identify your samples from others based on these labels.

Please contact the lab if you have any questions

FAILURE TO COMPLY WITH SAMPLING REQUIREMENTS MAY RESULT IN SAMPLE REJECTION

FIELD NOTES:

pg. 2 of 2

Tracking Information					
Relinquished By:	Date	Time	Received By:	Date	Time
Nicole Forbes	9/13/17	1415	gl	9/13/17	1415

**R&M ENGINEERING-KETCHIKAN, INC.****ENGINEERS GEOLOGISTS SURVEYORS**

355 CARLANNA LAKE ROAD, SUITE 200, KETCHIKAN, ALASKA 99901

PHONE (907) 225-7917 FAX (907) 225-3441 EMAIL: RNIMMain@rmketchikan.com

ADEC Division of Water
 Attn: Gretchen Pikul
 410 Willoughby Ave
 Jumeau, AK 99811

Ketchikan BEACH

Sampler: Nicole Forbes
 Date: 9/13/2017
 Time: 0938-1235
 Matrix: Marine water
 Type: Grab

LAB RECEIVING

Date: 9/13/2017
 Time: 1415

LAB REPORTING

Date: 9/15/2017
 Time: 1500

ANALYST: JML

Lab #	Sample Name	Analysis	Date Tested	Time Tested	Results	Units	MRL	Method
24251	KB-Rotary	FC	9/13/2017	1520	6	cfu / 100 ml	1.0	9222D
		ENTERO	9/13/2017	1540	26.2	MPN / 100 ml	1.0	D6503
24252	KB-Seaport	FC	9/13/2017	1520	21	cfu / 100 ml	1.0	9222D
		ENTERO	9/13/2017	1540	12.0	MPN / 100 ml	1.0	D6503
24253	KB-Mt Point	FC	9/13/2017	1520	22	cfu / 100 ml	1.0	9222D
		ENTERO	9/13/2017	1540	21.3	MPN / 100 ml	1.0	D6503
24254	KB-Thomas Basin	FC	9/13/2017	1520	13	cfu / 100 ml	1.0	9222D
		ENTERO	9/13/2017	1540	70.3	MPN / 100 ml	1.0	D6503
24255	KB-Refuge	FC	9/13/2017	1520	4	cfu / 100 ml	1.0	9222D
		ENTERO	9/13/2017	1540	13.5	MPN / 100 ml	1.0	D6503
24256	KB-Sunset	FC	9/13/2017	1520	17	cfu / 100 ml	1.0	9222D
		ENTERO	9/13/2017	1540	9.5	MPN / 100 ml	1.0	D6503
24257	KB-Shull	FC	9/13/2017	1520	9	cfu / 100 ml	1.0	9222D
		ENTERO	9/13/2017	1540	8.4	MPN / 100 ml	1.0	D6503
24258	KB-S Pt Higgins	FC	9/13/2017	1520	2	cfu / 100 ml	1.0	9222D
		ENTERO	9/13/2017	1540	9.5	MPN / 100 ml	1.0	D6503
24259	KB-Beacon Hill	FC	9/13/2017	1520	8	cfu / 100 ml	1.0	9222D
		ENTERO	9/13/2017	1540	9.7	MPN / 100 ml	1.0	D6503
24260	KB-Knudson	FC	9/13/2017	1520	12	cfu / 100 ml	1.0	9222D
		ENTERO	9/13/2017	1540	14.5	MPN / 100 ml	1.0	D6503

Appendix C – Site Photographs



Knudson Cove (KIC photo taken July 31, 2017)



Knudson Cove (KIC photo taken July 31, 2017)



Knudson Cove (KIC photos taken August 9, 2017)



Beacon Hill monitoring location (KIC photo taken July 29, 2017)



South Point Higgins monitoring location (KIC photo taken July 31, 2017)



South Point Higgins monitoring location (KIC photo taken July 31, 2017)



Shull monitoring location (KIC photo taken July 31, 2017)



Shull monitoring location (KIC photo taken July 31, 2017)



Sunset monitoring location (KIC photo taken July 31, 2017)



Refuge Cove monitoring location (KIC photo taken August 1, 2017)



Refuge Cove monitoring location (KIC photo taken July 24, 2017)



Refuge Cove monitoring location (KIC photo taken August 1, 2017)



Thomas Basin monitoring location (KIC photo taken August 8, 2017)



Thomas Basin monitoring location (KIC photo taken August 8, 2017)



Thomas Basin monitoring location (KIC photo taken August 8, 2017)



Thomas Basin monitoring location (KIC photo taken August 8, 2017)

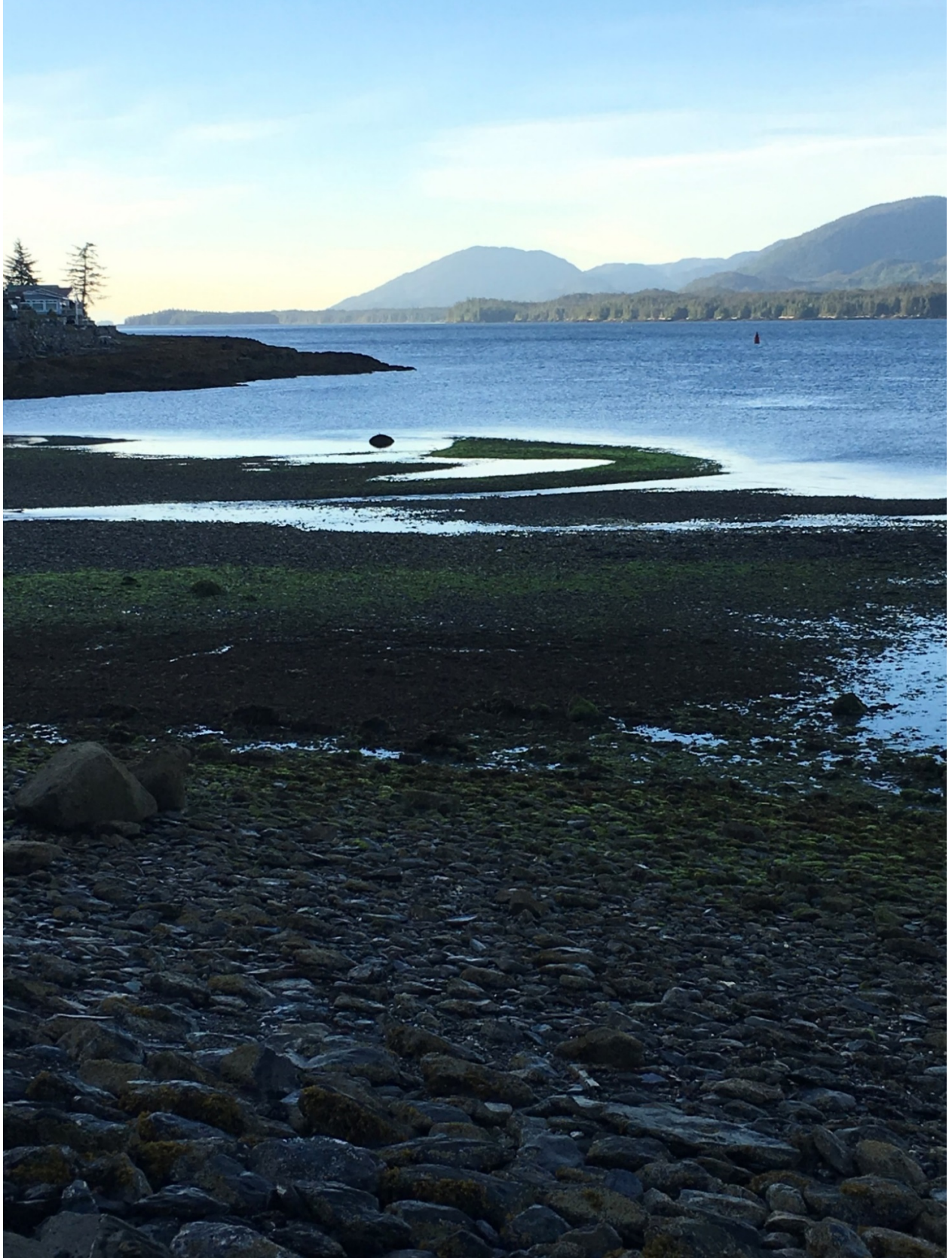

Seaport monitoring location (KIC photo taken August 8, 2017)



Seaport monitoring location (KIC photo taken August 8, 2017)



Seaport monitoring location (KIC photo taken July 24, 2017)



Seaport monitoring location (KIC photo taken July 24, 2017)



Rotary Park monitoring location (KIC photo taken August 1, 2017)



Rotary Park monitoring location (KIC photo taken August 1, 2017)



Rotary Park monitoring location (KIC photo taken August 1, 2017)



Rotary Park monitoring location (KIC photo taken August 8, 2017)



Rotary Park monitoring location (KIC photo taken August 8, 2017)

Appendix D – DEC Ketchikan BEACH Water Quality Monitoring and Pathogen Detection Quality Assurance Project Plan and Ketchikan BEACH Monitoring Handbook

Ketchikan BEACH Water Quality Monitoring and Pathogen Detection

July 2017

Quality Assurance Project Plan



**Alaska Department of Environmental Conservation
Division of Water**

A. Project Management Elements

A.1 Title and Approvals

Title: Tier 2 Quality Assurance Project Plan for Water Quality Monitoring Sampling and Analysis Activities

Tony Gallegos, Project Manager
Ketchikan Indian Cultural Resources Director

Phone: (907) 228-9312
email: tgallegos@kictribe.org

Signature: _____

Date: _____

Nicole Forbes, Project QA Officer
Ketchikan Indian Community Environmental
Specialist

Phone: (907) 228-9312
email: nforbes@kictribe.org

Signature: _____

Date: _____

Gretchen Pikul, DEC DOW Project Manager
DEC DOW WQS Program

Phone: (907) (465-5023)
email: gretchen.pikul@alaska.gov

Signature: _____

Date: _____

Douglas Kolwaite, DEC DOW QA Officer
DEC DOW WQSAR Program

Phone: (907) (465-5305)
email: douglas.kolwaite@alaska.gov

Signature: _____

Date: _____

Ketchikan BEACH QAPP

28 June 2017

A. Project Management Elements

A.1 Title and Approvals

Title: Tier 2 Quality Assurance Project Plan for Water Quality Monitoring Sampling and Analysis Activities

Tony Gallegos, Project Manager
Ketchikan Indian Community Executive Director

Phone: (907) 228 9312
email: agallegos@kicribe.org

Signature: 

Date: 7/17/17

Nicole Forbes, Project QA Officer
Ketchikan Indian Community Environmental Specialist

Phone: (907) 228 9312
email: nforbes@kicribe.org

Signature: 

Date: 7/17/17

Gretchen Pikul, DEC DOW Project Manager
DEC DOW WQS Program

Phone: (907) (465-5023)
email: gretchen.pikul@alaska.gov

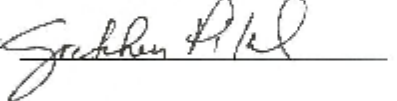
Signature: 

Date: 7-3-17

Douglas Kolwaite, DEC DOW QA Officer
DEC DOW WQSAR Program

Phone: (907) (465 5305)
email: douglas.kolwaite@alaska.gov

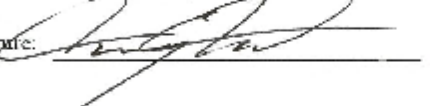
Signature: 

Date: 6/28/17

Table of Contents

A. Project Management Elements.....	2
A.1 Title and Approvals.....	2
A.2 Distribution List.....	7
A.3 Project Task/Organization.....	7
A.3.1 Project Grantee.....	7
A.3.2 DEC Staff:.....	8
A.4 Problem Definition/Background and Project Objectives.....	9
A.4.1 Problem Definition.....	9
A.4.2 Project Background.....	10
A.4.3 Project Objective(s).....	10
A.5 Project/Task Description and Schedule.....	10
A.5.1 Project Description.....	10
A.5.2 Project Implementation Schedule.....	11
A.6 Data Quality Objectives and Criteria for Measurement Data.....	11
A.6.1 Data Quality Objectives (DQOs).....	11
A.6.2 Measurement Quality Objectives (MQOs).....	11
A.7 Special Training Requirements/Certification.....	15
A.8 Documents and Records.....	16
B. Data Generation and Acquisition.....	18
B.1 Sampling Process Design (Experimental Design).....	18
B.1.1 Define Monitoring Objectives(s) and Appropriate Data Quality Objectives.....	19
B.1.2 Characterize the General Monitoring Location/s.....	20
B.1.3 Identify the Site-Specific Sample Collection Location/s, Parameters to be Measured and Frequencies of Collection.....	20
B.2 Sampling Method Requirements.....	21
B.2.1 Sample Types.....	21
B.2.2 Sample Containers and Equipment.....	21
B.2.3 Sampling Methods.....	22
B.3 Sample Handling and Custody Requirements.....	23
B.3.1 Sampling Procedures.....	23
B.3.2 Sample Custody Procedures.....	23
B.3.3 Shipping Requirements.....	23
B.4 Analytical Methods and Requirements.....	24

B.4.1	Sampling Parameters	24
B.5	Quality Control Requirements	25
B.5.1	Field Quality Control (QC)	25
B.5.2	Laboratory Quality Control (QC) Measures	26
B.6	Instrument/Equipment Testing, Inspection and Maintenance Requirements	27
B.7	Instrument Calibration and Frequency	27
B.8	Inspection/Acceptance of Supplies and Consumables	27
B.9	Data Acquisition Requirements (Non-Direct Measurements)	28
B.10	Data Management	28
C.	Assessment and Oversight	31
C.1	Assessments and Response Actions	31
C.1.1	Lab Assessments to be performed under the BEACH Monitoring Program:	31
C.1.2	On-Site assessments to be performed under the BEACH Monitoring Program:	32
C.1.3	Project Data Assessments:	32
C.2	Revisions to QAPP	32
C.3	QA Reports to Management	33
D.	Data Validation and Usability	33
D.1	Data Review, Verification and Validation Requirements	33
D.1.1	Data Validation	34
D.1.2	Data Verification	34
D.1.3	Data Review	34
D.2	Verification and Validation Methods	34
D.2.1	Validation Methods	34
D.2.2	Verification Methods	35
D.3	Reconciliation with User Requirements	35
E.	Decision Criteria	36
Appendix A:	Water Sampling Collection Protocols	37
A.1	Water Sample Collection	38
A.2	Sample Collection Method	38
A.3	Sample Handling	39
Appendix B:	Supporting Documentation	42
B.1	Beach Sampling Field Forms	42
B.2	Chain of Custody Form	45

B.3	Statement of Qualifications.....	46
B.4	Sampling Location Maps.....	48

Table of Tables

Table 1: Distribution List	7
Table 2: Project Implementation Schedule.....	11
Table 3: Project Measurement Quality Objectives (MQOs)	14
Table 4: Training.....	16
Table 5: Project Documents and Records	18
Table 6: Site Location and Rationale	20
Table 7: Site-Specific Sample Parameters to be Measured and Collection Frequency.....	21
Table 8: Preservation and Holding Times for the Analysis of Samples	22
Table 9: Sample Transport Chain Information.....	24
Table 10: Field Quality Control Samples	26
Table 11: QA Reports to Management	33

Table of Figures

Figure 1: BEACH Project Organizational Structure	9
Figure 2: Data Management Flow Chart.....	31
Figure 3: Data Review Decision Flowchart.....	36

A.2 Distribution List

This list includes the names and addresses of those who receive copies of the approved QAPP and subsequent revisions.

Table 1: Distribution List				
NAME	POSITION	AGENCY/ Company	DIVISION/BRANCH/SECTION	CONTACT INFORMATION
Gretchen Pikul	DEC Project Manager	DEC	Division of Water/ Water Quality Standards/Beach Grant	907-465-5023 gretchen.pikul@alaska.gov
Douglas Kolwaite	DEC QA Officer	DEC	Division of Water/ WQSAR/QA	907-465-5305 douglas.kolwaite@alaska.gov
Shera Hickman	EH Lab QA Manager	DEC	Division of Environmental Health/Laboratory Services	907-375-7799 shera.hickman@alaska.gov
Sherri Trask	EH Lab DW Micro Certification Officer	DEC	Division of Environmental Health/Laboratory Services	907-375-8209 sherri.trask@alaska.gov
Tony Gallegos	KIC Project Manager	KIC	Executive Director	907-228-9312 tgallegos@kictribe.org
Nicole Forbes	KIC Lead Field Sampler	KIC	Environmental Specialist	907-228-9312 nforbes@kictribe.org
Joel Salter	EPA Beach Grant Oversight	EPA	EPA Region 10, Oregon operations office	503-326-2653 salter.joel@epamail.epa.gov

A.3 Project Task/Organization

Duties and responsibilities of key individuals are listed below:

A.3.1 KIC Staff

- Project Manager/Project QA Officer** – Responsible for overall technical and contractual management of the project. If KIC staff have direct responsibility for sample collection and analysis of data results, the KIC Project Manager assume the responsibilities of the Lead Field Sampler/Project Manager.

Responsible to ensure all monitoring complies with the QAPP specified criteria. This is accomplished through routine technical assessments of the sample collection, analysis and data reporting process. Assessments may include, but are not limited to activities such as: on-site field audits, data audits, QA review of blind lab performance evaluation samples, and lab audits. These assessments are performed independent of overall project management.

- **Lead Field Sampler** – Responsible for sampling preparation, sample collection, sample preservation, transportation of samples to laboratory for analysis, receipt of data and transmittal of data to Project Manager. The individual will procure personal equipment of field personnel, coordinate with laboratories in planning sampling equipment needs, obtain supplies for and prepare daily sampling kits prior to departure for field location, travel to the field location, prepare necessary preservatives while in the field, perform site reconnaissance, collect site specific parameters, collect water samples, prepare samples for shipping, transport samples to laboratory, alert laboratory of successful sampling event, receive data from laboratory, verify sample result data is reliable and submit the data and all applicable QA/QC results to the DEC Project Manager.
- **Field Support Personnel** - Responsible for accompanying Lead Field Sampler into the field and supporting Lead Field Sampler during sampling. The individual will travel with the Lead Field Sampler to the field location, accompany the Lead Field Sampler to sampling sites, and support Lead Field Sampler in sampling tasks.
- **Laboratory Manager** – Responsible for the overall review and approval of contracted laboratory analytical work, responding to sample result inquiries and method specific details. Responsible for QA/QC of laboratory analysis as specified in the QAPP and reviews and verifies the validity of sample data results as specified in the QAPP and appropriate EPA approved analytical methods.

A.3.2 DEC Staff:

- **DEC Project Manager** – Responsible for overall technical and contractual management of the project. If DEC staff have direct responsibility for sample collection and analysis of data results, the DEC Project Manager/s assume the responsibilities of the Lead Field Sampler/Project Manager.
- **DEC Water Quality Assurance Officer (WQAO)** – Responsible for QA review and approval of plan and oversight of QA activities ensuring collected data meets project's stated data quality goals. If DEC staff have direct responsibility for sample collection and analysis of data results, the DEC WQAO assumes the responsibilities of the Project QA Officer.

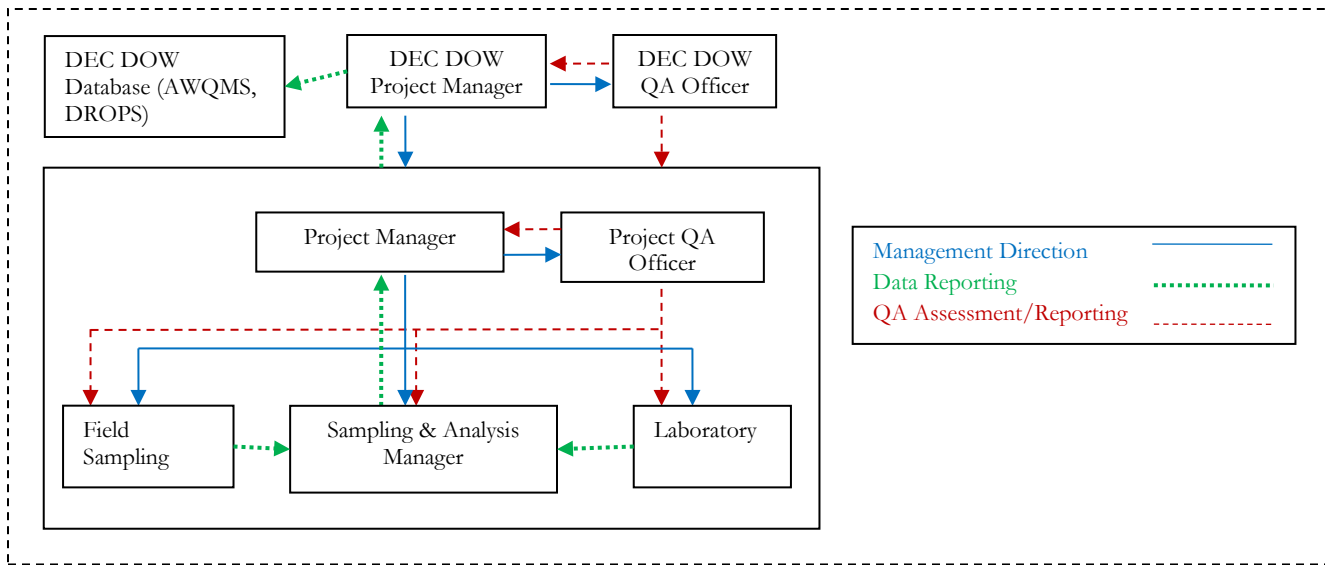

Figure 1: BEACH Project Organizational Structure

A.4 Problem Definition/Background and Project Objectives

A.4.1 Problem Definition

DEC identified the following beaches through a public nomination process; the Recreational Beach Survey is available at: <http://dec.alaska.gov/water/wqsar/wqs/beachprogram.htm>. The qualifying Ketchikan Beaches are listed below.^{1,2}

- Rotary Park Beach 55° 18' 31.50" N 131° 34' 39.34" W; 55.30875000, -131.57777778
- Seaport Beach 55° 18' 52.63" N 131° 35' 35.68" W; 55.31461944, -131.59333333
- Thomas Basin 55° 20' 28.49" N 131° 38' 30.45" W; 55.34124722, -131.64166667
- South Refuge Cove State Recreation Site 55° 24' 26.62" N 131° 45' 19.77" W; 55.40739444, -131.75555556
- Beach at Sunset Drive 55° 24' 45.40" N 131° 45' 54.19" W; 55.41261111, -131.76500000
- Beach at Shull Road 55° 26' 7.57" N 131° 47' 54.62" W; 55.43543611, -131.79861111
- South Point Higgins Beach 55° 26' 55.12" N 131° 49' 52.90" W; 55.44864444, -131.83138889
- Beacon Hill 55° 28' 20.21" N 131° 49' 22.98" W; 55.47228056, -131.82305556
- Knudson Cove 55° 28' 19.47" N 131° 47' 46.76" W; 55.47207500, -131.79638889

Based on the information provided by respondents, DEC ranked these beaches as Tier 1. Tier 1 includes high priority beaches that pose the greatest threat of human contact with contaminated waters during

¹ One replicate of each analysis will be taken each at sampling event.

² Lat/long coordinates may be revised based on specific field sample location.

recreational use. Contact with waters containing fecal contamination increases the risk of becoming ill due to pathogens contained in feces.

A.4.2 Project Background

DEC has and continues to implement a Beach Grant monitoring model which partners with local interested organizations and the general public to monitor levels of fecal contamination and evaluate the potential risks associated with recreational beach use. While this model is effective in providing support to communities monitoring marine water quality adjacent to high use beaches, it has not been successful in monitoring all high priority, Tier 1, beaches in Alaska on a desirable basis. Data associated with monitoring efforts at these beaches are on file and can be obtained by contacting the Project Manager.

A.4.3 Project Objective(s)

The primary objective of this DEC BEACH Monitoring Program project is to sample identified beaches for fecal indicator organisms (fecal coliforms and enterococci bacteria) that signify the presence of fecal contamination. This information will be used to notify the public in the event an exceedance of allowable levels of indicator organisms in accordance to Alaska Water Quality Standards (WQS).

The secondary objective is to obtain a set of at least five samples per beach within a 30-day period. The geometric mean of these samples will then be used when reevaluating the ranking of these beaches as Tier 1. If the geometric mean of a beach meets WQS standards, it is possible the beach will be downgraded to a lower Tier. This would reduce the number of beaches categorized as high priority and, assuming no new beaches are nominated and ranked as high priority, increase the percentage of high priority beaches that can be monitored at a desirable frequency.

A.5 Project/Task Description and Schedule

A.5.1 Project Description

DEC/ KIC will collect water samples from nine 9 Tier 1 beaches along the coast of Ketchikan. Samples will be analyzed in a DEC-approved laboratory for presence of fecal coliforms by SM 9222 D, and Enterococci by ASTM D6503. The goal of this project is to gather enough data to determine whether these beaches are meeting the water quality standards for fecal coliforms and enterococci based on single sample and/or geometric mean calculations. A list of DEC-approved microbiological laboratories is available at: <https://dec.alaska.gov/applications/eh/EHLabStatus/MicroReport/Index>.

A.5.2 Project Implementation Schedule

Table 2: Project Implementation Schedule				
Product	Measurement/ Parameter(s)	Sampling Site	Sampling Frequency	Time Frame
Field Sampling	Ambient air temperature, water temperature	All sites	See sample schedule based on tides	July 18-August 10, 2017
Lab Analysis	Fecal coliforms and Enterococci	All sites	Analyses within sample holding time requirements	July 18-August 10, 2017
Field Audit	Audit of field monitoring operations	All sites	< 30 days of project start-up	1/project

A.6 Data Quality Objectives and Criteria for Measurement Data

A.6.1 Data Quality Objectives (DQOs)

Data Quality Objectives (DQOs, EPAQA/G4). DQOs are qualitative and quantitative statements derived from the DQO Process that:

- Determine ambient beach water concentrations of indicator organisms (fecal coliforms and enterococci) and compare these values to water quality standards regulatory limits for fecal coliform bacteria in marine waters.
- The data needed for this project is indicator organism concentrations. The ultimate goal of the project is to intensively monitor beaches that are currently considered Tier I to determine if there truly is a problem with fecal contamination. If so, beaches may be listed as impaired waters. If not, beaches will be down-tiered to a lower priority level. In order to accomplish the monitoring objectives, the appropriate type of data needed is defined by the WQS for bacteria (fecal coliform and enterococci). For WQS pollutants, compliance with the WQS is determined by specific measurement requirements. The measurement system is designed to produce water pollutant concentration data that are of the appropriate quantity and quality to assess compliance.

A.6.2 Measurement Quality Objectives (MQOs)

Measurement Quality Objectives (MQOs) are a subset of DQOs. MQOs are derived from the monitoring project's DQOs. MQOs are designed to evaluate and control various phases (sampling, preparation, and analysis) of the measurement process to ensure that total measurement uncertainty is within the range prescribed by the project's DQOs. MQOs define the acceptable quality (data validity) of field and laboratory data for the project. MQOs are defined in terms of the following data quality indicators:

- Detectability
- Precision
- Bias/Accuracy
- Completeness

- Representativeness
- Comparability

Detectability is the ability of the method to reliably measure a pollutant concentration above background. DEC DOW uses two components to define detectability: method detection limit (MDL) and practical quantification limit (PQL) or reporting limit (RL).

- The MDL is the minimum value which the instrument can discern above background but no certainty to the accuracy of the measured value. For field measurements the manufacturer's listed instrument detection limit (IDL) can be used.
- The PQL or RL is the minimum value that can be reported with confidence (usually some multiple of the MDL).

Note: The measurement method of choice should at a minimum have a practical quantification limit or reporting limit 3 times more sensitive than the respective DEC WQS and/or permitted pollutant level (for permitted facilities).

Sample data measured below the MDL is reported as ND or non-detect. Sample data measured \geq MDL but \leq PQL or RL is reported as estimated data. Sample data measured above the PQL or RL is reported as reliable data unless otherwise qualified per the specific sample analysis.

Precision is the degree of agreement among repeated measurements of the same parameter and provides information about the consistency of methods. Precision is expressed in terms of the relative percent difference (RPD) between two measurements (A and B).

For field measurements, precision is assessed by measuring replicate (paired) samples at the same locations and as soon as possible to limit temporal variance in sample results. Field and laboratory precision is measured by collecting blind (to the laboratory) field replicate or duplicate lab samples. For paired and small data sets project precision is calculated using the following formula:

$$Precision = \frac{(A - B)}{((A + B)/2)} \times 100$$

For larger sets of paired precision data sets (e.g., overall project precision) or multiple replicate precision data, the following formula may be used:

$$RSD = 100 * (\text{standard deviation} / \text{mean})$$

Note: Precision assessed only when both paired values \geq :

- 5 times PQL (fecal coliforms SM 9222D)
- 2 times PQL (enterococci D-6503-99)
- 5 times PQL (fecal coliforms SM 9221 E (2) with A-1 media)

Bias (Accuracy) is a measure of confidence that describes how close a measurement is to its "true" value. Methods to determine and assess accuracy of field and laboratory measurements include, instrument calibrations, various types of QC checks (e.g., sample split measurements, sample spike recoveries, matrix

spike duplicates, continuing calibration verification checks, internal standards, sample blank measurements (field and lab blanks), external standards), performance audit samples (DMRQA, blind Water Supply or Water Pollution PE samples from A2LA certified, etc.), Bias/Accuracy is usually assessed using the following formula:

$$\text{Accuracy} = \frac{\text{Measured Value}}{\text{True Value}} \times 100$$

Completeness is a measure of the percentage of valid samples collected and analyzed to yield sufficient information to make informed decisions with statistical confidence. As with representativeness, data completeness is determined during project development and specified in the QAPP. Project completeness is determined for each pollutant parameter using the following formula:

$$\frac{T - (I + NC)}{T} \times 100\% = \text{Completeness}$$

Where: T = Total number of expected sample measurements.

I = Number of invalid sample measured results.

NC = Number of sample measurements not produced (e.g., spilled sample, etc).

This project has a goal of 80% data completeness. Completeness will be assessed on an individual basis for every beach. For comparison with the geometric mean standard, ten individual sampling events are planned and a minimum of five unique and valid samples (per sample location) are required to assess compliance with the beach monitoring water quality indicator standards.

Representativeness is determined during project development and specified in the QAPP.

Representativeness assigns what parameters to sample for, where to sample, type of sample (grab, continuous, composite, etc.) and frequency of sample collection.

Comparability is a measure that shows how data can be compared to other data collected by using standardized methods of sampling and analysis.

Each sampling station is fixed and located by reference to a permanent landmark at each beach. The stations do not change throughout the sampling season, but may vary with tidal stage. Sampling is conducted in accordance with Alaska Beach Grant Program's Standard Operating Procedures. The SOP's are contained within the Sample Handbook available at:

<http://www.dec.state.ak.us/water/wqsar/wqs/beachprogram.htm>

Standardized EPA-approved analytical procedures methods are used by state certified microbiological laboratories. Fecal coliform bacteria colony forming units are enumerated using EPA Method 9222D. Enterococci colony forming units are enumerated using Standard Test Method D6503-99.

Table 3: Project Measurement Quality Objectives (MQOs)

Group	Analyte	Method	MDL	PQL	Alaska Water Quality Standards				Precision (RPD)	Accuracy
					Aquatic Life	Recreation Water	Harvesting for Consumption of Raw Mollusks or Other Raw Aquatic Life			
	Temperature	In situ (electronic probe) EPA 170.1	NA	0.1°C	<20°C Migration routes < 15°C Spawning areas < 13°C Rearing areas < 15°C Egg / fry incubation < 13°C	<30°C	NA	±0.2°C	±0.2°C	
	Fecal coliforms	SM 9222D, membrane filtration (MF)	1 cfu/100mL	1 cfu/100mL	NA	Geometric Mean: 100 cfu/100 mL Single Sample: 200 cfu/100mL	NA	+/- 60%	NA	
Fecal Indicator Organisms	Fecal Coliforms	SM9221 E (2) with A-1 media, MPN, marine growing waters method	2-1600 MPN/100mL	2-1600 MPN/100mL	NA	NA	14MPN fc/100mL and not more than 10% samples may exceed 200 MPN fc/100mL.	+/- 60%	NA	
	Enterococci	D6503-99 (Enterococci by Enterolert)	10cfu/100mL	10cfu/100mL	NA	Geometric Mean: 35 cfu/100mL Statistical Threshold Value: 130 cfu/100mL	NA	+/- 60%	NA	

A.7 Special Training Requirements/Certification

The DEC Project Managers currently serve as DEC DOW's BEACH Grant coordinator and have experience in administrating BEACH Grant Monitoring Program grants. The experience associated with their duties allows them to be effective in carrying out duties as Project Manager.

For BEACH monitoring projects, the entity is responsible to provide a knowledgeable and competent grant manager, project QA Officer and Lead Field Sampler.

For BEACH monitoring projects conducted by DEC staff, the Project QA Officer is the DEC DOW's Quality Assurance Officer. His training and experience allows him to successfully fulfill his duties as Project QA Officer.

Sub-contracted laboratories performing analytical work must have the requisite knowledge and skills in execution of the analytical methods being requested. Information on laboratory staff competence is usually provided in each lab's Quality Management (QMP) and/or Quality Assurance Plan (QAP). The laboratory to be used during the 2017 field season, R&M Engineering, Inc., is an Alaska Drinking Water certified microbiological laboratory. It is the responsibility of the contracted lab to maintain a current copy of the laboratory's QA Plan and attendant method specific SOPs on file with the Project Manager/ QA Project Manager and DEC DOW QA Officer during the duration of laboratory use.

DEC Project Manager: Gretchen Pikul

DEC QA Officer: Doug Kolwaite

KIC Project Manager/QA Officer: Tony Gallegos, KIC Executive Director

KIC Project Lead Field Sampler: Nicole Forbes, Environmental Specialist

KIC Field Support Personnel: TBA

Table 4: Training					
Specialized Training/Certification	Field Staff	Project Manager	Lab Staff	Lab Supervisor	Project QA Officer
Safety training	X	X	X	X	X
Water sampling techniques	X	X			X
Instrument calibration and QC activities for field measurements	X	X			X
Instrument calibration and QC activities for laboratory measurements			X	X	X
QA principles				X	X
Chain of Custody procedures for samples and data	X	X	X	X	X
Specific EPA Approved Field Measurement Method Training	X	X			X
DEC Microbiological Drinking Water Certification	Certification for microbiological analysis is limited to the individually certified analyst.				
Specific EPA Approved Lab Analytical Method Training			X	X	X

A.8 Documents and Records

The EPA's Marine Sanitary Survey app will be used to record field and sanitary survey information (<https://www.epa.gov/beach-tech/beach-sanitary-surveys#app>). A field logbook may also be used to store individual field and sanitary survey forms. Please see the Appendix for an example of logbook documents. The lead field sampler is responsible for ensuring that the all field data forms are correct.

If the EPA's Marine Sanitary Survey app is not used, then all field activities and observations will be noted in a field logbook during fieldwork. The descriptions will be clearly written with enough detail so that participants can reconstruct events later if necessary. Field logbooks will describe any changes that occur at the site, in particular, personnel and responsibilities or deviations from the QAPP/SAP as well as the reasons for the changes. Requirements for logbook entries will include the following:

- Pages will be numbered at the outset of the sampling season.
- Removal of any pages, even if illegible, will be prohibited.
- Entries will be made legibly with black (or dark) waterproof ink.
- Unbiased, accurate language will be used.
- Entries will be made while activities are in progress or as soon afterward as possible (the date and time that the notation is made should be noted, as well as the time of the observation itself). Each consecutive day's first entry will be made on a new, blank page.
- The date and time, will appear on each page.
- When field activity is complete, the logbook will be entered into the project file.

In addition to the preceding requirements, the person recording the information must initial and date each page of the field logbook. If more than one individual makes entries on the same page, each recorder must initial and date each entry. The bottom of the page must be signed and dated by the individual who makes the last entry. The field team and task leader, after reading the day's entries, also must sign and date the last page of each daily entry in the field logbook. Logbook corrections will be made by drawing a single line through the original entry allowing the original entry to be read. The corrected entry will be written alongside the original. Corrections will be initialed and dated and may require a footnote for explanation. The type of information that may be included in the field logbook and/or field data forms includes the following:

- Names of all field staff
- A record of site health and safety meetings, updates, and related monitoring
- Station name and location
- Date and collection time of each sample
- Observations made during sample collection, including weather conditions, environmental conditions, complications, and other details associated with the sampling effort
- Sample description
- Any deviation from the sampling plan

Field log books and sample chain-of-custody forms will be completed for all samples and kept in the project file. Laboratory data results from the laboratories are recorded on laboratory data sheets, bench sheets and/or in laboratory logbooks for each sampling event. These records as well as control charts, logbook records of equipment maintenance records, calibration and quality control checks, such as preparation and use of standard solutions, inventory of supplies and consumables, check in of equipment, equipment parts and chemicals are kept on file at the laboratory.

Any procedural or equipment problems are recorded in the field notebooks. Any deviation from this Quality Assurance Project Plan will also be noted in the field notebooks. Data results will include information on field and/or laboratory QA/QC problems and corrective actions.

In addition to any written report, data collected for the project will be provided electronically in a AQWMS/STORET compatible format, as detailed in the following web address:

http://dec.alaska.gov/water/wqsar/awq_data_info.htm.

All records will be retained according to state records retention schedule.

Table 5: Project Documents and Records			
Categories	Record/Document Types	Location	Retention Time
Site Information	Site maps	With KIC	Five Years
	Site pictures	With KIC	Five Years
Environmental Data Operations	QA Project Plan	DEC	Five Years
	Field Method SOPs	With KIC	Five Years
	Field Notebooks	With KIC	Five Years
	Sample collection/measurement records	KIC and DEC	Five Years
	Sample Handling & Custody Records	KIC and DEC	Five Years
	Inspection/Maintenance Records	KIC and DEC	Five Years
Raw Data	Lab data (sample, QC and calibration) including data entry forms	KIC and DEC	Five Years
	Sanitary Survey Forms	KIC and DEC	Five Years
Data Reporting	Progress reports	N/A	Five Years
	Project data/summary reports	N/A	Five Years
	Lab analysis reports	DEC	Five Years
Data Management	Data quality assessments	DEC	Five Years
	Site audits	DEC	Five Years
	Lab audits	DEC	Five Years
	QA reports/corrective action reports	DEC	Five Years
	Corrective Action Response	DEC	Five Years

In addition to any written report, data collected for a project will be submitted electronically to DEC via a CD ROM or email ZIP file. All dates are to be formatted as “**MM-DD-YYYY**”.

B. Data Generation and Acquisition

B.1 Sampling Process Design (Experimental Design)

Beach water quality monitoring will be conducted at Tier I beaches designated by DEC, and sample locations should be chosen to represent the most likely pathogen exposure scenario for recreational beach users. Water samples will be analyzed to determine the population densities of microbes that indicate the presence of fecal contamination; microbes to be enumerated will be enterococci and fecal coliforms, with the results reported per 100 mL marine water.

Samples will be collected in accordance with the sampling SOP (Appendix A-1) at locations where primary contact recreation is likely to affect beach users. Sample collection information specific to this project is included in the Appendix A-1.

The sample will be collected in nearshore water 3 feet deep, approximately one foot below the water surface. Replicate samples for fecal coliform and enterococcus will be collected for each batch.

Enterococcus and fecal coliform population densities will be determined using the EPA or DEC approved protocols yielding the most rapid results. Those protocols were selected so decisions regarding issuance of beach advisories may be made without undue delay, minimizing the potential for public health risks associated with ongoing pathogen exposure.

B.1.1 Define Monitoring Objectives(s) and Appropriate Data Quality Objectives

Objective 1: Conduct five (5) sampling events within a 30-day period in July/August 2018.

Description: Ketchikan Indian Community (KIC) will collect conduct five (5) sampling rounds within a 30-day period from July 18 through August 11, 2017 in accordance with the DEC-approved Quality Assurance Project Plan and BEACH Monitoring Handbook (these documents are complete and available to KIC). A contingent sampling round is scheduled for August 9 and 10 to address any unforeseen sampling issues.

The marine water samples will be analyzed for fecal coliform bacteria (SM 9222D) and enterococci (ASTM D6503-99). One replicate sample for each analytical test per sampling event will be collected for quality assurance.

Eleven (11) locations will be sampled: Rotary Beach Park, Seaport Beach, South Refuge Cove State Recreation Site, beach off Sunset Drive, beach at Point Susan Road, beach at Shull Road, South Point Higgins Beach (North and South), Beacon Hill, Knudson Cove, beach at Potter Point, beach at First Waterfall Creek, and one (1) QA laboratory sample per analyte per sampling event (alternating between sampling locations). Since all 11 locations cannot be sampled during one event and meet the tidal cycle, 2 consecutive day sampling events will occur to collect all 11 locations. Each sampling event requires one (1) QA laboratory sample, resulting in two (2) QA laboratory samples per sampling round. A total of 14 samples per event will be collected. A sampling schedule and tidal cycles is attached in an excel spreadsheet.

Sample collection will target low tides to assess worst case bacteria scenarios. Specifically sampling collection will occur 3 hours prior to and during low tide at the outgoing tides (ebb tide), and during low tide up to 3 hours after in coming tides (flood tide). Sampling events will alternate between these ebb and flood tide cycles in order to capture various tidal scenarios.

Field parameters will include visual observations listed in EPA's Marine Beach Sanitary Survey app, such as water clarity, and water and air temperature.

KIC will conduct the sampling events and ensure that proper sampling techniques are followed, chain-of-custody is correct, and samples are received and analyzed by the laboratory to meet the analytical holding time requirements. Samples will be delivered to the DEC-certified laboratory R&M Engineering-Ketchikan, Inc. in Ketchikan Alaska to meet the six (6) hour holding time for analysis.

The DEC Project Manager will travel to Ketchikan to meet KIC staff, and conduct site selection and sampling training prior to 30-day sample period.

The initial analytical data results, sanitary surveys, copies of the chain-of-custody forms, and site photos will be provided to the DEC Project Manager within 36 hours of the sampling event. The final analytical data results will be provided to the DEC Project Manager when it is submitted to KIC by the laboratory.

B.1.2 Characterize the General Monitoring Location/s

In 2002 and 2003, an Alaska Beach Survey was conducted to collect information about recreational-use beaches in the state. The survey was designed to obtain information regarding the locations of recreational-use beaches, the types of recreational activities that occur there, and the levels and seasons of beach use. In addition, information regarding the types of pollution sources near these recreation areas was collected. The collected information was entered into a database and was used to rank beaches according to their relative potential pathogen-exposure risk to beach users. The results of this survey were used to create the Alaska Beach Database, which is updated as additional surveys are received.

Table 6: Site Location and Rationale			
Site ID	Latitude	Longitude	Site Description
KB-Rotary	55° 18' 31.50" N	-131° 34' 39.34" W	Rotary Beach Park Beach
KB-Seaport	55° 18' 52.63" N	-131° 35' 35.68" W	Seaport Beach
KB-ThomasBasin	55° 20' 28.49" N	-131° 38' 30.45" W	Thomas Basin Harbor
KB-RefugeCove	55° 24' 26.62" N	-131° 45' 19.77" W	South Refuge Cove State Recreation Site
KB-Sunset	55° 24' 45.40" N	-131° 45' 54.19" W	Beach of Sunset Drive
KB-Shull	55° 26' 7.57" N	-131° 47' 54.62" W	Beach at Shull Road
KB-SPHiggins	55° 26' 55.12" N	-131° 49' 52.90" W	South Point Higgins Beach
KB-BeaconHill	55° 28' 20.21" N	-131° 49' 22.98" W	Beacon Hill
KB-KnudsonCove	55° 28' 19.47" N	-131° 47' 46.76" W	Knudson Cove
Note: GIS Maps of sampling locations (large scale as well as site specific) are to be located in the Appendix as part of the sampling plan.			

B.1.3 Identify the Site-Specific Sample Collection Location/s, Parameters to be Measured and Frequencies of Collection

Specific sampling sites will not be known until field reconnaissance has been performed. It is likely that sampling will occur at the point of greatest ease of public access. It will be assumed that the greatest use will occur at the point of greatest ease of public access.

An area within short walking distance of the public access point will most likely be sampled at each beach. The sites depicted in the topographic maps found in Appendix B.4 are tentative.

The following table details parameters to be taken at each site, the sampling frequency, and the sampling dates.

Table 7: Site-Specific Sample Parameters to be Measured and Collection Frequency			
Measurement/ Parameter(s)	Sampling Site	Sampling Frequency	Sampling Dates
Grab: Fecal Coliforms, Enterococci In situ ambient air temperature, water temperature	All sample locations	Weekly - biweekly	July-August 2017

B.2 Sampling Method Requirements

Specific sampling methods are detailed in the Sampling SOP, included in the Appendix of this QAPP.

B.2.1 Sample Types

Samples will be listed as “grab” on the Chain-of- Custody and in field data sheets.

B.2.2 Sample Containers and Equipment

The following general guidelines are listed to provide consistency among the samples collected from Alaskan beaches:

- Collect one sample for each recreational-use area. A sample will consist of one sample container filled with water from one location. The container will be analyzed to determine fecal coliform population densities and enterococcus populations.
- Wear hip-waders, elbow-length gloves and a life vest during sampling.
- Collect samples in areas of greatest use by recreational users, where water is about 3 feet deep, at about knee-depth or one foot below the surface.
- Collect a field replicate sample with a minimum of one replicate per analytical test per sampling day. A field replicate consists of one additional sample container filled with water at the same location where the primary water sample set was collected.
- All sample bottles will be pre-cleaned and sterilized, and will not require rinsing with sample.
- Remove the sample container cap carefully, avoid touching the inside of the cap or the lip of the sampling container, and face into the waves or the current to avoid sample container contamination.
- Minimize sediment or debris in the sample; this may require waiting for sediment to settle after wading out to the sample collection location. If sediment or debris are present throughout the sample area, note this fact on the Beach Sampling Data Sheet.
- Grasping the open sampling container at the bottom with one hand, plunge the bottle mouth downward into the water to avoid introducing any surface scum. Position the mouth of the bottle into the current while standing downstream of the sample bottle. Tip the bottle upward to allow air to exit and the bottle to fill, and remove the bottle from the water. Pour out a small portion of the sample from the bottle to allow airspace of about 1 inch for proper mixing before analysis. Replace

the cap on the bottle and assure it is tightly closed. Label the sample bottle with sample identifier, date, and time.

- List samples as “grab” on the laboratory’s chain of custody (COC) form. Note on the COC form that the laboratory needs to send the bacterial data to three recipients: to the local beach monitor, to the DEC Project Manager, and to the DEC QA Officer.
- Place samples into a cooler containing frozen blue ice to maintain a chilled temperature below 10° C. The cooler should be pre-chilled before sampling begins to ensure that samples are kept cold from the time of sampling until they are analyzed. A temperature blank must be included in each cooler.
- Measure and record water temperature to 0.1°C at the time of sample collection. A note of the temperature of the cooler contents will be made upon arrival at the laboratory.

The sample container, preservation, and holding time requirements are tabulated below:

Table 8: Preservation and Holding Times for the Analysis of Samples					
Analyte	Matrix	Container	Necessary Volume	Preservation and Filtration	Maximum Holding Time
Temperature	Surface Water	N/A, direct measurement	N/A, Direct Measurement	N/A, direct measurement	N/A, direct measurement
Fecal Coliform	Surface Water	G, PA	100 mL	Cool <10°C; do not freeze, 0.0008% Na ₂ S ₂ O ₃	6 hours (field) 2 hrs lab prep (note: time not additive)
Enterococci	Surface Water	G,PA	100 mL	Cool <10°C; do not freeze, 0.0008% Na ₂ S ₂ O ₃	6 hours (field) 2 hrs lab prep (note: time not additive)
Notes: G = glass, PA = autoclavable plastic					

B.2.3 Sampling Methods

Sampling Standard Operating Procedures (SSOP) are located within the Sample Handbook available at: <http://www.dec.state.ak.us/water/wqsar/wqs/beachprogram.htm>. A copy of the SSOP is located in the appendix.

Beach Grab Samples – Sample bottles will be filled sequentially, normally being filled to the shoulder of the bottle, leaving a small space for expansion and mixing. The laboratory will provide sampling instructions with the sample bottles.

B.3 Sample Handling and Custody Requirements

B.3.1 Sampling Procedures

See Section B.2 of this QAPP – Sampling Method Requirements SOP.

B.3.2 Sample Custody Procedures

Samples and sample containers will be maintained in a secure environment from the time the bottles leave the laboratory until the samples are received at the laboratory. The laboratories will maintain custody of bottles and samples using their normal custody procedures.

Samples must be in the sampler's possession or in a cooler sealed with signed and dated friable evidence tape on opposing sides of the cooler. When the cooler is sealed, the method of securing the samples must be such that tampering with samples or bottles is not possible. The cooler must be secured so that the lid cannot be removed without breaking the evidence tape or cutting the lock.

Transfer of samples will be accomplished using the laboratory's Chain-of-Custody (COC) form. When samples are transferred between personnel, such transfer will be indicated on the COC form with signature, date, and time of transfer. The COC will remain with the samples, sealed inside the cooler, until received by the laboratory. KIC should provide a copy of the contracted lab COC at the end of this QAPP (Appendix A-2).

If custody is broken at any time during sample transfer, a note must be made on the COC form accompanying the sample. Upon receipt at the laboratory, the laboratory sample custodian will make note if a breach of custody has occurred (for example, if a custody seal has broken during transport).

B.3.3 Shipping Requirements

Packaging, marking, labeling, and shipping of samples will comply with all regulations promulgated by the U. S. Department of Transportation in 49 CFR 171-177. Staff should receive the necessary training for shipping samples or consult with the contracted laboratory for shipping instructions.

Samples will be individually packaged in sealed plastic bags. The sealed plastic bags will be placed into a bag-lined cooler with ice sealed in plastic bags or "blue-ice" to maintain a temperature of less than four degrees C. A temperature blank, 250 or 500 mL in size, will be placed in the cooler. Temperature will be measured prior to shipment and upon receipt at the lab. The chain of custody (COC) form will be placed in a plastic bag within the cooler. The cooler will be taped closed securely using packing tape at the last sampling site.

The six hour holding time limitation for the samples must be met. To accomplish this, this project will use a combination of transportation to get the samples from beach to laboratory within the specified hold time. For those projects without laboratories in their communities, samples will be packaged at the sampling site, driven by car to the nearest airport, picked up by a courier, and then delivered to the laboratory. Other projects will deliver samples directly to the contracted laboratory.

Table 9: Sample Transport Chain Information						
Business Type	Name	Address	Hours	Contact Information	Transport Leg	Estimated Transit Time
Deliver directly to laboratory	R&M Engineering, Inc.	355 Carlanna Lake Road Ketchikan AK 99901	8:00 am – 4:00 pm	(907) 225-7917	Motor Vehicle	30 minutes

B.4 Analytical Methods and Requirements

Water quality analytical methods that will be used throughout this project are outlined below. All analysis methods used for this program are EPA-approved. The contracted laboratory will be a currently DEC Drinking Water -certified laboratory, though the lab will be using methods specified for water/wastewater analysis. The contracted laboratory's current Quality Assurance Plan will be on file with DEC Division of Water Quality Assurance Office detailing their quality assurance procedures. Laboratory turnaround time is 20 business days. Any issues regarding analytical data quality will be resolved by the DEC project manager in consultation with any or all of the following: DEC QA Officer, sampling staff and the laboratory project manager.

B.4.1 Sampling Parameters

Temperature will be reported in °C, and will be measured using a YSI 650 MDS multiprobe meter or an equivalent meter (minimum resolution of 0.1 degree C or better). The thermometer will have current NIST traceable certification.

Fecal Coliform Standard Method 9222D will be used to determine the fecal coliform concentration in surface water. Filter sample through a membrane filter. Place membrane on mFC agar containing aniline blue as indicator. Incubate at 44.5°C for 22-24 h. Colonies that are various shades of blue are positive for fecal coliforms. The blue color indicates the capability to ferment lactose to acid.

Enterococci ASTM Method D6503-99 will be used to determine the most probable number enterococci concentration in surface water. Add reagent to the sample, pour into Quanti-Tray® or Quanti-Tray® /2000, seal in Quanti-Tray® Sealer and incubated for 24 hours at 41°C. Count fluorescent wells and refer to most probable number table.

Fecal Coliform Standard Method 9221A SM9221 E (2) with A-1 media, MPN, marine growing waters method. This method describes multiple-tube fermentation procedures [also called the most probable number (MPN) procedure] for the detection and enumeration of fecal coliform bacteria in biosolids. These methods use culture-specific media and elevated temperature to isolate and enumerate fecal coliform organisms.

Monitoring shall be conducted in accordance with EPA-approved analytical procedures and in compliance with 40 CFR Part 136, Guidelines Establishing Test Procedures for Analysis of Pollutants. Reference the

Project's MQO Table 3(section A.6.2) of this QAPP for list of parameters of concern, approved analytical methods, method-specific detection and reporting limits, accuracy and precision values applicable to this project. 40 CFR, Part 136.6 lists other regulated pollutant parameters not listed in the MQO Table 3(section A.6.2).

An expedited reporting turnaround time after sampling will be required for laboratory microbiological analyses to obtain results quickly for decision-making purposes. As pathogen exposure remains a risk to beach users during the period between sample analysis and reporting sample results, a short reporting time is recommended; a period of 36 hours following sample submission should be used for reporting results to the QAO, the BPM, and local community point of contact.

B.5 Quality Control Requirements

Table 10 lists the percent of field and laboratory replicates to be used for quality control (See section A.6.2 for discussion on calculation of precision and accuracy). The precision of field and laboratory measures will be calculated using the equation in section A.6.2. Data measurements that do not meet the limits described in A.6.2 may or may not be used in the final report depending on degree to which limits are not met. However, the report will clearly flag any and all data of questionable value along with a brief description of the problem and any justification why data should be considered for use.

Blind field sample replicates will be collected at a count of one sample per analyte per sampling event (alternating between sampling locations). Since all 11 locations cannot be sampled during one event and meet the tidal cycle, two consecutive day sampling events will occur to collect all 11 locations. Each sampling event requires one sample per analyte, resulting in two samples per analyte per sampling round. They will be analyzed for enterococci and fecal coliform (both methods, SM 9222 D and SM 9221 E with A1 media) population densities. The purpose of the blind field sample replicates is to assess sampling and laboratory precision and overall method variability for each BEACH monitoring project.

For laboratory analyses, contract laboratories will submit quality control results along with sample analytical results. Laboratory Quality Control will include duplicates, holding times, sample temperatures upon receipt of sample at lab and blanks. Laboratory precision criteria should be within BEACH MQO criteria provided in Section A.6.

B.5.1 Field Quality Control (QC)

Measures Quality control activities in the field will include adherence to documented procedures and the comprehensive documentation of sample collection information included in the field notebooks. A rigidly enforced chain-of-custody program will ensure sample integrity and identification. The chain-of-custody procedure documents the handling of each sample from the time the sample was collected to the arrival of the sample at the laboratory.

Quality Control measures in the field include but are not limited to:

- Proper cleaning of sample containers and sampling equipment.

- Maintenance, cleaning and calibration of field equipment/ kits per the manufacturers and/or laboratory’s specifications, and field Standard Operating Procedures (SOPs).
- Chemical reagents and standard reference materials are used prior to expiration dates.
- Proper field sample collection and analysis techniques.
- Correct sample labeling and data entry.
- Proper sample handling and shipping/transport techniques.
- Field replicate measurements at a minimum of one sample for each analyte per sampling event.

Analytical methods used on the project have been approved and documented by EPA, Standard Methods, or ASTM. These methods will be used as project-specific protocols to document and guide analytical procedures. Adherence to these documented procedures will ensure that analytical results are properly obtained and reported.

Table 10: Field Quality Control Samples				
Field Quality Control Sample	Measurement Parameter/s	Frequency		QC Acceptance Criteria Limits
		Frequency of Occurrence	Total # of QC Type Samples	
Temperature blank	fecal coliforms, enterococci, fecal coliforms (marine waters growing method)	1/ Cooler		Rec'd at lab ≤10°C
Project samples (QC samples, blanks, samples)		All		Analyzed within holding times
Field replicates		1 per analyte/per batch		≤ ± 60 RPD

B.5.2 Laboratory Quality Control (QC) Measures

Laboratories detail QC procedures used in their laboratory Quality Assurance Plan and method specific SOPs Quality Control in laboratories includes the following:

- Laboratory instrumentation calibrated with the analytical procedure.
- Laboratory instrumentation maintained in accordance with the instrument manufacturer’s specifications, the laboratory’s QAP and Standard Operating Procedures (SOPs).
- Specific QC activities prescribed in the project’s QAPP.
- Laboratory data verification and validation prior to sending data results to DEC.

Contracted and sub-contracted laboratories will provide analytical results after verification and validation by the laboratory QA Officer. The laboratory must provide all relevant QC information with its summary of data results so that the project manager and project QA officer can perform field data verification and

validation, and review the laboratory reports. The project manager reviews these data to ensure that the required QC measurement criteria have been met. If a QC concern is identified in the review process, the Project Manager and Project QA Officer will seek additional information from the sub-contracted laboratory to resolve the issue and take appropriate corrective action/s.

B.6 Instrument/Equipment Testing, Inspection and Maintenance Requirements

Contracted and sub-contracted laboratories will follow the testing, inspection and maintenance procedures required by EPA Clean Water Act approved methods and as stated in the respective laboratory's QAP and SOPs.

B.7 Instrument Calibration and Frequency

Field instruments shall be calibrated where appropriate prior to using the instruments. If equipment and/or kits require calibration immediately prior to the sampling event, the calibration date will be recorded in the operator's field logbook or field data sheets. When field instruments require only periodic calibration, the record of this calibration should be kept with the instrument. The project manager will delegate a field project team member to ensure that instruments are calibrated correctly and appropriate documents recorded and retained.

Thermometers will be calibrated annually against a currently certified NIST traceable thermometer at a minimum of two (2) temperatures that bracket temperatures expected in the field (e.g., 0°C and 20°C). The NIST traceable thermometer must be certified over the expected field measurement range and should have greater accuracy and measurement resolution than the field thermometer.

Contracted and sub-contracted laboratories will follow the calibration procedures found in its QAP and the laboratory's Standard Operating Procedures (SOPs). Specific calibration procedures for regulated pollutants will be in agreement with the respective "EPA Approved" Clean Water Act Pollutant methods of analysis. Field and/or Laboratory calibration records will be made available to DEC upon request.

B.8 Inspection/Acceptance of Supplies and Consumables

All reagents, calibration standards, and kit chemicals are to be inspected to ensure that expiration dates have not been exceeded prior to use in the monitoring project.

Pre-cleaned sample containers will be obtained from the lab with the appropriate preservation method included. Coolers, gel ice, temperature blanks, and chain-of-custody forms will be provided by the contract laboratory prior to field mobilization. Qualified staff will check all field equipment and supplies to ensure that their technical specifications have been met before use. Any deviances during inspection procedures will be remedied by the project manager and recorded in the field notebook. If re-sampling becomes necessary, replacements will be made.

No standards, solutions, buffers, or other chemical additives will be used if the expiration date has passed. It is the responsibility of the sampling manager or his/her designee to keep appropriate records, such as logbook entries or checklists, to verify the inspection/acceptance of supplies and consumables, and restock these supplies and consumables when necessary.

Contracted and sub-contracted laboratories will follow procedures in their laboratory's QAP and SOPs for inspection/acceptance of supplies and consumables.

B.9 Data Acquisition Requirements (Non-Direct Measurements)

Topographic non-direct measurements (e.g., maps, charts) will be conducted using USGS derived materials. All geographical materials will be listed according to their source, year, and scale. GPS information will be documented by including collection device make and model number, geographic coordinate system, degree of accuracy (minimum of three satellite signals), and calibration information. GIS information will include GIS software program and model, source information, and geographic coordinate system.

B.10 Data Management

The success of a monitoring project relies on data and their interpretation. It is critical that data be available to users and that these data are:

- Of known quality,
- Reliable,
- Aggregated in a manner consistent with their prime use, and
- Accessible to a variety of users.

Quality Assurance/Quality Control (QA/QC) of data management begins with the raw data and ends with a defensible report, preferably through the computerized messaging of raw data.

Data management encompasses and traces the path of the data from their generation to their final use or storage (e.g., from field measurements and sample collection/recording through transfer of data to computers (e.g., laptops, data acquisition systems), laboratory analysis, data validation/verification, QA assessments and reporting of data of known quality to the respective DEC Division of Water Program Office. It also includes/discusses the control mechanism for detecting and correcting errors. Please include a flow chart (see example at end of section) as well as a detailed narrative of the monitoring project's data management process.

Various people are responsible for separate or discrete parts of the data management process:

- The field samplers are responsible field measurements/sample collection and recording of data and subsequent shipment of samples to laboratories for analyses. They assemble data files, which includes raw data, calibration information and certificates, QC checks (routine checks), data flags, sampler comments and metadata where available. These files are assembled and forwarded for secondary data review by the sampling supervisor.
- Laboratories are responsible to comply with the data quality objectives specified in the QAPP and as specified in the laboratory QAP and method specific SOPs. Validated sample laboratory data results are reported to the sampling coordinator/supervisor/project supervisor.
- Secondary reviewers (sampling coordinator/supervisor/project supervisor) are responsible for the QC the review, verification and validation of field and laboratory data and data reformatting as

appropriate for reporting to AWQMS/STORET, and reporting validated data to the project manager.

- The project QA officer is responsible for performing routine independent reviews of data to ensure the monitoring projects data quality objectives are being met. Findings and recommended corrective actions (as appropriate) are reported directly to project management.
- The project manager is responsible for final data certification.
- DEC DOW project manager and QA Officer AQS data entry staff conducts a final review (tertiary review) and submits the validated data to AWQMS/STORET.

An example Data Management Flow Chart (Figure 2) provides a visual summary description of the data flow/management process for environmental data collected in support of DEC's Division of Water decision making processes. Please revise as appropriate for the monitoring project.

Daily field records (a combination of field and core logbooks data sheets) will make up the main documentation for field activities. As soon after collection as possible, field notes, data sheets, core logs, and chain-of-custody forms will be scanned to create an electronic record. Field data will be hand-entered into the database. One-hundred percent of the transferred data will be verified based on hard copy records. Electronic QA checks to identify anomalous values will also be conducted following entry.

Data obtained during sampling activities will be entered into field notebooks.

The following is a list of data information that will be kept and submitted to DEC:

- Field equipment and chemicals maintenance, cleaning and calibration records;
- Field notebooks;
- Sample Data Sheets;
- Photographs of sampling stations and events;
- Chain-of-Custody forms;
- Laboratory equipment maintenance, cleaning and calibration records;
- Laboratory bench sheets, control charts, and SOPs;
- Records of QA/QC problems and corrective actions (field and/or laboratory);
- Laboratory data QC records;
- Records of data review sheets;
- Replicate, performance evaluation records and other QA/QC control records (field and laboratory); and
- Data review, verification and validation records.

Data handling equipment will include computer software applications Microsoft Excel and Access. Data will be entered by the DEC project manager into a database in a form compatible with requirements of the statewide database entry into AWQMS. Requirements for data entry can be found at http://dec.alaska.gov/water/wqsar/awq_data_info.htm#2.

Sample Numbering

All samples will be assigned a unique identification code based on a sample designation scheme designed to suit the needs of the field personnel, data management, and data users. Sample identifiers will consist of two components separated by dashes. The first component is used to identify the area to which the sample originated, for example: KR = Kenai River.

Laboratory Data

The contract laboratory will submit data in electronic format to DEC. Written documentation will be used to clarify how field replicates and laboratory duplicates and QA/QC samples were recorded in the data metatables and to provide explanations of other issues that may arise. The data management task will include keeping accurate records of field and laboratory QA/QC samples so that project managers and technical staff who use the data will have appropriate documentation. Data management files will be stored on a secure computer or on a removable hard drive that can be secured. All records will be retained by the contract laboratory for five years.

Data Storage and Retention

Data management files will be stored on a secure computer or on a removable hard drive that can be secured. Laboratory Records will be retained by the contract laboratory for a minimum of five years. Project records will be retained by the lead organization conducting the monitoring operations for a minimum of five years, preferably longer. Site location and retention period for the stored data will be specified in each QAPP.

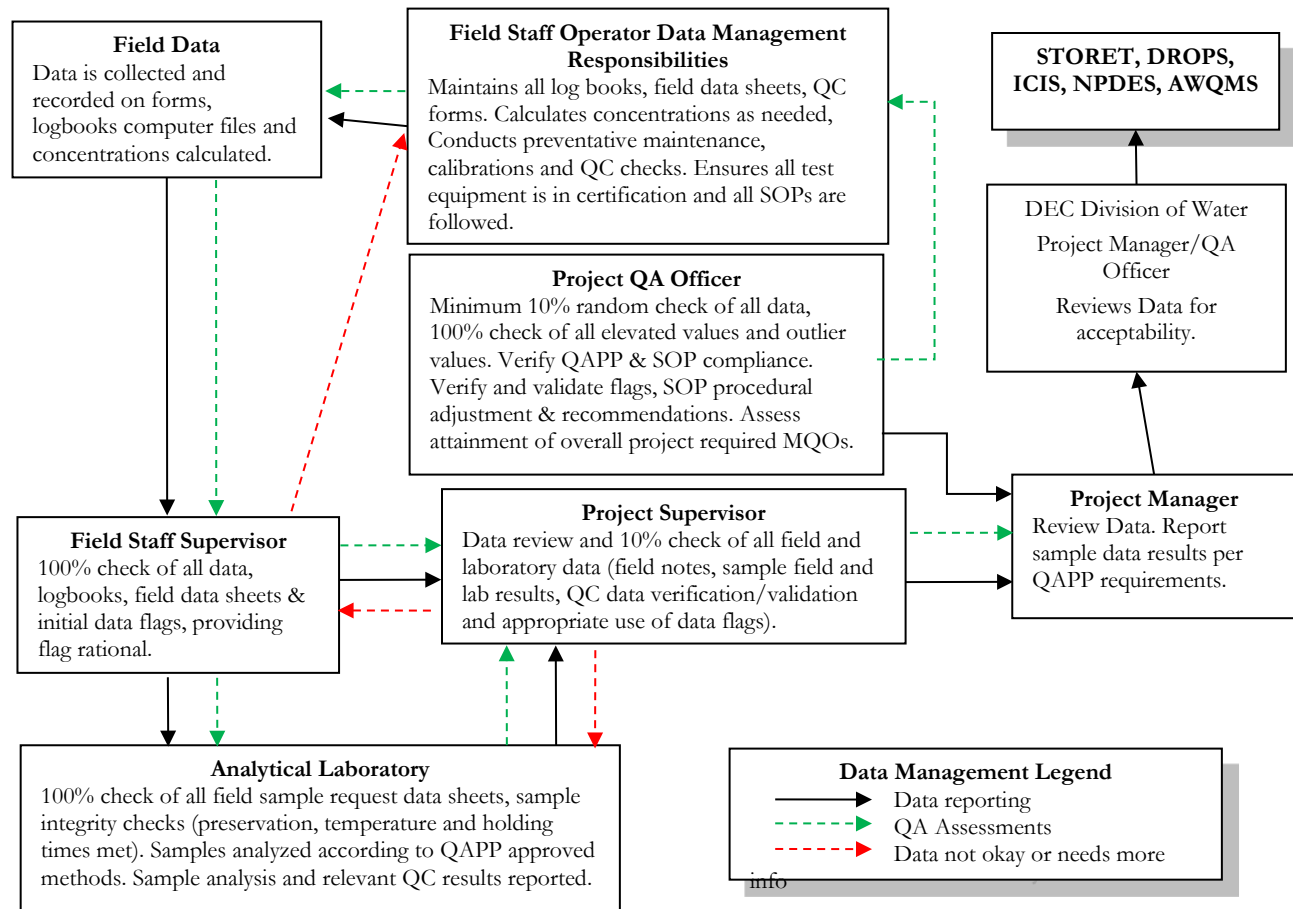

Figure 2: Data Management Flow Chart

C. Assessment and Oversight

C.1 Assessments and Response Actions

Assessments are independent evaluations of the monitoring project that are performed by the Project’s QA Officer or his/her designee. Assessments may include (but are not limited to) any of the following: on-site field surveillance, on-site laboratory audits, performance evaluation samples, blind sample duplicates/replicates (precision samples), field split samples, data quality audits, data reviews. The number and types of assessments are dependent upon the monitoring project’s intended data uses.

C.1.1 Lab Assessments to be performed under the BEACH Monitoring Program

Blind 3rd party lab performance evaluation (PE samples also called Performance Test, PT samples) for microbial analytes/methods of interest. PT water/wastewater sample participation is at a frequency of 1/year from a NELAC certified vendor (<http://www.nelac-institute.org>). Microbiological samples must be analyzed by a current DEC EH Drinking Water certified lab (<http://dec.alaska.gov/applications/eh/EHLabStatus/MicroReport/Index>) for the methods of interest.

For those microbiological methods not covered under the DEC EH Lab DW certification program, the microbiological lab will enroll in an approved PT study for the microbiological method of interest (see above link for approved NELAC PT vendors). Laboratory 3rd party microbiological PT samples results will be submitted directly to the DEC Water QA Officer and the Monitoring Project's QA Officer.

Note 1: It is the responsibility of the laboratory to enroll itself in these blind PT studies with the results mailed/emailed directly to the DEC DOW Water Quality Assurance Office and the Monitoring Project's QA Officer. Routine laboratory performance in the blind PT sample studies will be used to assess overall laboratory data quality as well as monitoring project data quality.

Note 2: It is the responsibility of the Project Manager and project QA Officer to ensure the selected laboratory is self-enrolled in a NELAC certified PT water/wastewater study at a frequency of 1/year.

C.1.2 On-Site assessments to be performed under the BEACH Monitoring Program

- One on-site field audit/BEACH monitoring operation (contractor) of sample collection procedures (each pollutant/method). Audit evaluates whether procedures used for sample collection, preservation, shipping and hold times and sample receipt at lab are in compliance with QAPP requirements.

C.1.3 Project Data Assessments

- Audits of Monitoring Data for reproducibility of results from recalculation/reconstruction of field/lab data.
- Calculation of monitoring project's overall achieved precision, accuracy and data completeness compared to QAPP defined precision, accuracy and data completeness goals. Method specific precision, accuracy and data completeness criteria is specified in the Project MQO Table 3 of section A.6.2.
- End of monitoring project QA summary report. Describes whether project data quality objectives and measurement quality objectives were obtained. Identifies whether exceedances of Alaska's Water Quality Standards were measured, water quality monitoring problems encountered and corrective actions that were taken.

C.2 Revisions to QAPP

Annually the QAPP will be reviewed and revised as needed. Minor revisions may be made without formal comment. Such minor revisions may include changes to identified project staff, QAPP distribution list and/or minor editorial changes.

Revisions to the QAPP that affect stated monitoring Data Quality Objectives, Method Quality Objectives, method specific data validation "critical" criteria and/or inclusion of new monitoring methods must solicit input/ and pre-approval by DEC DOW QA Officer/DEC Project Management before being implemented.

C.3 QA Reports to Management

Use the following table to describe assessment types, frequency, content, responsible individual/s, and distribution of assessment reports to management and other recipients and actions to be taken.

Table 11: QA Reports to Management					
QA Report Type	Contents	Presentation Method	Report Issued by	Reporting Frequency	
				As Required	Year
On-site Field Inspection Audit Report	Description of audit results, audit methods and standards/equipment used and any recommendations	Written text and tables, charts, graphs displaying results	Project QA Officer/auditor	✓	1/BEACH contract project
3 rd Party PT (e.g., DMRQA) Audit Report	Description of audit results, methods of analysis and any recommendations	Written text and charts, graphs displaying results	Project QA Officer/auditor	✓	1/year
Corrective Action Recommendation	Description of problem(s); recommended action(s) required; time frame for feedback on resolution of problem(s)	Written text/table	QA Officer/auditor	✓	
Response to Corrective Action Report	Description of problem(s), description/date corrective action(s) implemented and/or scheduled to be implemented	Written text/table	Project Manager overseeing sampling and analysis	✓	
Data Quality Audit	Independent review and recalculation of sample collection/analysis (including calculations, etc) to determine sample result. Summary of data audit results; findings; and any recommendations	Written text and charts, graphs displaying results	Project QA Officer	✓	
Quality Assurance Report to Management	Project executive summary: data completeness, precision, bias/accuracy	Written text and charts, graphs displaying results	Project QA Officer	✓	✓

D. Data Validation and Usability

D.1 Data Review, Verification and Validation Requirements

The purpose of this section is to define the criteria that will be used to review and validate—that is, accept, reject or qualify data in an objective and consistent manner. It is a way to decide the degree to which each data item has met its quality specifications as described in Element B above.

D.1.1 Data Validation means determining if data satisfy QAPP-defined user requirements; that is, that the data refer back to the overall data quality objectives. Data validation is an analyte and sample-specific process that extends the evaluation of data beyond method, procedural, or contractual compliance (i.e., data verification) to determine the analytical quality of a specific data set to ensure that the reported data values meet the quality goals of the environmental data operations (method specific data validation criteria).

D.1.2 Data Verification is the process of evaluating the completeness, correctness, and conformance/compliance of a specific data set against the method, procedural, or contractual requirements.

D.1.3 Data Review is the process that evaluates the overall data package to ensure procedures were followed and that reported data is reasonable and consistent with associated QA/QC results.

D.2 Verification and Validation Methods

D.2.1 Validation Methods

Data validation determines whether the data sets meet the requirements of the project-specific intended use as described in the QAPP. That is, were the data results of the right type, quality, and quantity to support their intended use? Data validation also attempts to give reasons for sampling and analysis anomalies, and the effect that these anomalies have on the overall value of the data.

All data generated shall be validated in accordance with the QA/QC requirements specified in the methods and the technical specification outlined in this QAPP. Raw field data will be maintained by the Program staff who collect it. Raw laboratory data shall be maintained by the laboratory. The laboratory may archive the analytical data into their laboratory data management system. All data will be kept a minimum of 3 years.

The summary of all laboratory analytical results will be reported to the Project supervisor/manager staff. Data validation will be performed by the laboratory for all analyses prior to the release of data. All laboratory data will be validated according to the laboratory's QAP and SOPs and as specified in the Monitoring Project's QAPP. The rationale for any anomalies in the QA/QC of the laboratory data will be provided to the Project Manager with the data results. Completed Chain-of-Custody or Transmission forms (if required) will be sent back from the laboratory to the Project Manager.

Data will be qualified as necessary. Sampling may need to be repeated. Unacceptable data (i.e., data that do not meet the QA measurement criteria of precision, accuracy, representativeness, comparability and completeness) will not be used or if used, the problems with the data will be clearly defined, flagged appropriately and data use clearly delimited and justified. Any actions taken to correct QA/QC problems in sampling, sample handling, and analysis must be noted. Under the direction of the project manager, project staff will document any and all QA/QC problems and QA/QC corrective actions taken.

The Project Manager/monitoring supervisor or his/her designee is responsible for reviewing field log notebooks and field data sheets for accuracy and completeness within 48 hours of each sample collection

activity, if possible. Sample results provided by the laboratory, will be verified and validated by the laboratory QA Officer prior to issuing the laboratory report, and will become part of the permanent file for the monitoring project. The Project Manager or his/her designee will compare the sample information in the field log notebooks and/or data field sheets with the laboratory analytical results to ensure that no transcription errors have occurred, and to verify project QC criteria have been met (e.g., samples preserved and sample hold times met as required by QAPP and method, relative percent difference (RPD) results for blind sample replicates).

The Project QA Officer or his/her designee will calculate the Relative Percent Difference (RPD) between field replicate samples.

Laboratories calculate and report the RPD and percent analyte recovery of analytical duplicate samples.

RPD's greater than the project requirements will be noted. The Project Manager, along with supervisors and/or the Project QA Officer, if necessary, will decide if any QA/QC corrective action will be taken if the precision, accuracy (bias) and data completeness values exceed the project's MQO goals.

Estimated Quantitation Limits

The estimated quantitation limits (EQLs) are the lowest concentration that can be reliably achieved within specified limits of precision and accuracy for field and lab measurement methods. Estimated quantitation limits should be equal to or below the reporting limit (RL) but above the method detection limit (MDL). These method and analyte specific limits are provided in the MQO Table 3 (section A.6.2).

D.2.2 Verification Methods

The primary goal of verification is to document that applicable method, procedural and contractual requirements were met in field sampling and laboratory analysis. Verification checks to see if the data were complete, if sampling and analysis matched QAPP requirements, and if Standard Operating Procedures (SOPs) were followed.

Verification of data is the responsibility of the Project QA Officer. The Project QA Officer should verify at least 10% of generated project data.

D.3 Reconciliation with User Requirements

The Project Manager and the Project QA Officer will review and validate data against the Project's defined MQOs prior to final reporting stages. If there are any problems with quality sampling and analysis, these issues will be addressed immediately and methods will be modified to ensure that data quality objectives are being met. Modifications to monitoring will require notification to DEC and subsequent edits to the approved QAPP.

Only data that have been validated and qualified, as necessary, shall be provided to DEC Division of Water and entered into the applicable database (STORET, AWQMS, ICI-NPDES, DROPS).

E. Decision Criteria

Beach Advisories, Closures or other emergency actions may only be taken by municipalities in conjunction with the Department of Environmental Conservation.

The BEACH Program's decision criteria are based on EPA's ambient water quality criteria (EPA, 1986) for two reasons:

Enterococci have a better correlation between indicator levels and illness rates than fecal coliform.

Alaska's marine Bacteria Indicator Water Quality Standards protect for the consumption of shellfish. Protection from human illness due to primary marine water contact. Closing a beach or advising against water contact based on a not more than 10% of the samples may exceed 31 fecal coliform colonies/100mL and having a geometric mean of samples may not exceed 14 fecal coliform colonies/100mL [18AAC70(14)(D) harvesting for consumption of raw mollusks or other raw aquatic life] could result in excessive advisories. A financial hardship on local communities could result from unnecessary and excessive postings. Public confidence in the Beach Program could also drop resulting in a human health hazard due to future postings being ignored.

Management decisions for public health and safety at recreational beaches should be based on specific data (e.g., activities, sanitary surveys) including identification of possible impacts from pollution sources. To make the necessary decision, data must be indicative of water quality conditions to adequately assess sanitary conditions of the beach. Due to inherent uncertainty involved with sampling and analytical determination of bacteria levels, decisions will be made when there is no reason to doubt the accuracy of the sample.

Figure 3: Data Review Decision Flowchart

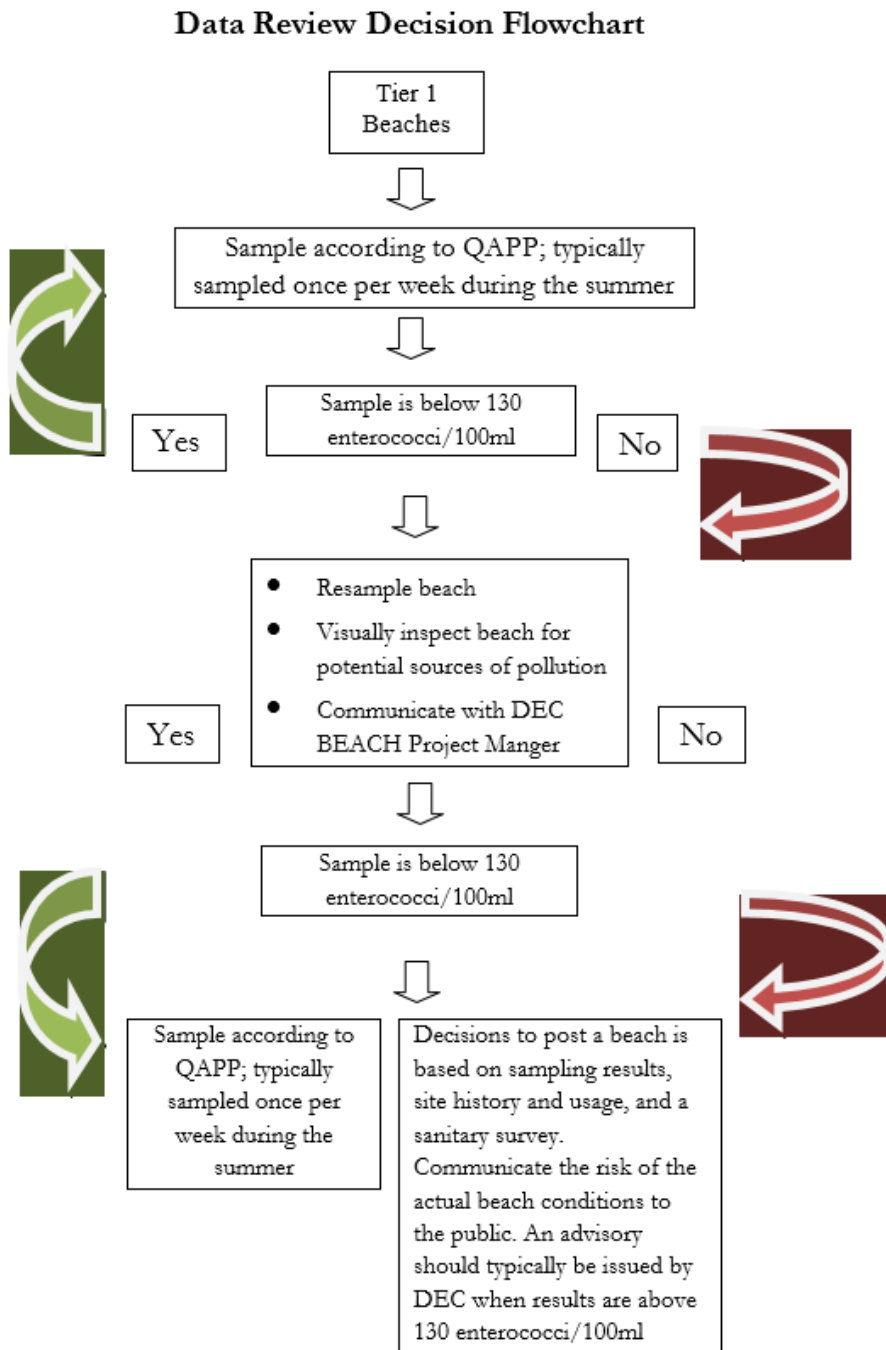

Appendix A-1: Water Sampling Collection Protocols

A.1 Water Sample Collection

Water sampling involves wading into the water adjacent to a beach commonly used for water recreation to collect water from below the surface into sample jars. The sample should be collected in the general recreational beach area, or near locations expected to be influenced by fecal contamination (e.g., adjacent to sewage lagoons, near small boat harbors, etc.). The BEACH Manager will complete sampling after the following steps have been accomplished:

- Each sample jar is filled with water.
- Each sample jar is labeled.
- Each sample jar is placed in a cooler kept chilled with artificial ice.
- The Beach Sampling Data Sheet is filled out.
- A chain-of-custody form is filled out.
- The cooler is transported to the laboratory responsible for determining fecal coliform and enterococcus populations.
- A copy of the Beach sampling Data Sheet is sent to DEC BEACH Manager.

Detailed directions for collecting good water samples, shipping the samples to the laboratory, and providing beach assessment information to the DEC are given in the following subsections.

A.2 Sample Collection Method

A good water sample is collected by avoiding cross-contamination, which can happen when the sampler inadvertently contaminates the sample. To reduce the potential for cross-contamination the sampler must follow a standard sample-collection method. Step-by-step sample-collection instructions are provided below:

1. Request a sample kit from the laboratory. The kit should include:
 - A cooler.
 - The appropriate sample containers for marine water-quality sampling (enterococcus and fecal coliform bacteria).
 - Artificial ice to keep the cooler chilled to the appropriate temperature.
 - Temperature blank.
 - Chain-of custody form.
 - Custody seals.
 - Sample jar labels.
 - An extra set of Sample bottles.
 - An extra set of sample bottles for a duplicate sample.
 - Shipping labels.

- Packing material.
2. **Call the laboratory prior to sampling** to make sure there will be someone at the laboratory to receive and process the samples within 6 hours of sampling.
 3. **If necessary, consult flight schedules** to make sure there will be a flight that can get the samples to the laboratory within 6 hours of sampling.
 4. Write the beach sampling location on the bottle label and Beach Sampling Data Sheet.
 5. Put on clean waders, gloves and life vest. Wade into the water to a depth of approximately 3 feet. Try to avoid kicking up sediment or wait until any sediment that has been kicked up settles. Stand downstream of the water current and wait for sediment to clear.
 6. Remove the bottle cap just before collecting the sample. Protect the cap from contamination. Do not touch the inside of the bottle, or the inside of the cap.
 7. Open the sampling bottle and hold onto the base with one hand. Plunge the top of the bottle downward into the water. Avoid introducing surface scum. Point the mouth of the bottle into the current. Hold the bottle about 1 foot below the water surface and tip it slightly upward to allow air to exit and the bottle to fill.
 8. Remove the bottle from the water. Pour out a little water to leave airspace at the top of the jar. Fill one 100-mL bottle at each sampling location.
 9. Tightly close each bottle.

Collect one replicate for each analyte per sampling event. To collect a replicate sample, you must first have requested extra jars from the laboratory. Repeat Steps 2 through 9 at the same location.

10. Complete bottle labels and attach them to each sample jar. Labels should be clean, waterproof, non-smearing, and large enough for all the information. Information on the label should include:
 - Sample identifier (e.g., “city-date-sample” = “KET-051707-01”)
 - Sample location (e.g., beach name, KB-Rotary)
 - Sampling date and time
 - Name of sampler
11. Wash your hands and arms with soap and water or waterless antimicrobial cleanser, or disinfectant lotion to reduce exposure to potentially harmful bacteria or microorganisms.

A.3 Sample Handling

Sample handling involves packing the samples in a cooler and shipping them to the laboratory. After sample collection is complete the samples must be handled with care so that they arrive to the laboratory in good condition. Step-by-step sample handling instructions are provided below:

1. Place the sample(s) in a pre-chilled cooler containing artificial ice to maintain a temperature from 1° to 10°C. Ask the laboratory ahead of time how much ice will be needed. **Do not allow the**

samples to freeze. Samples must remain below 10°C until receipt by qualified staff at the laboratory, otherwise samples are determined invalid so ensure sufficient cold artificial ice is added.

2. Place enough packing material inside the cooler to protect the sample jars from breaking during transport to the laboratory.
3. Complete the chain-of-custody form. Put the form in a plastic bag and tape it to the inside of the cooler lid.
 - Write a note in the “Special Instructions” box requesting that the laboratory results be sent without delay (within 36 hours of sampling) to three people: the DEC BEACH Project Manager, the DEC BEACH Quality Assurance Officer, and you.
4. Fill out two custody seals and attach one to the front and one to the back of the cooler to span the lid seam. You want them to tear when the cooler is opened.
5. Securely tape the cooler shut prior to shipment. Attach shipping labels that identify the shipping destination and say: “keep cool,” “do not freeze,” and “fragile.”
6. Ship the samples to DEC-certified laboratory R&M Engineering-Ketchikan, Inc. (907) 225-7917.

Remember that samples have to be collected, shipped and received by the laboratory in 6 hours.

Samples that exceed the 6-hour holding time will not be analyzed. If necessary, consult flight schedules, and call the laboratory prior to sampling to make sure there will be a flight that can get the samples to the laboratory within 6 hours of sampling, and that there will be someone at the laboratory to receive the samples.

Appendix B: Supporting Documentation

Appendix B.1: Beach Sampling Field Forms

BEACH Monitoring Handbook, Rev 1

July 5, 2011

BEACH SAMPLING FIELD FORM

Name of Beach _____ Date _____

Nearest Town _____

Describe Sampling Location (Note location on map and attach) _____

Latitude N _____ Longitude _____

SAMPLES

Sample(s) ID: _____ Time: _____

Replicate ID: _____ Time: _____

Field Blank ID: _____ Time: _____

Weather Conditions:

- Sunny & Clear
- Cloudy / Overcast
- Other (describe): _____
- Rain
- Fog
- Water Temperature: _____ °C
- Air Temperature: _____ °F °C
- Wind Speed (approx): _____ Mph
- Wind Direction: _____ On Shore Off Shore
- Precipitation in the last 24 hours: _____ in

Tidal Conditions:

- Low Tide
- High Tide
- Ebbing
- Flooding
- Tide** **Height** **Time**
- Low: _____ ft m _____ (am/pm)
- High: _____ ft m _____ (am/pm)

Condition of the beach:

	Debris (Describe)	Vegetation (% Coverage):
On shore		
In water		

Activity on the Beach

Adults _____ Dogs _____
 Children _____
 Other _____
 (describe): _____

Type of Activity

- Swimmers
- Walkers
- Fishermen
- Boaters
- Other
- (describe): _____

Condition of the Water:

- Clear
- Cloudy & Murky
- Oily Film
- Other
- (describe): _____

Potential Sources of Pollution

- Water Fowl (approx #): _____
- Boats (approx #): _____
- Other
- (describe): _____
- Sanitary Facilities (describe): _____
- Sewage odor/presence (describe): _____
- Presence of stormwater pipes or other flow across the beach (describe): _____

Additional comments, noteworthy unusual conditions:

 Sampler Name (Printed)

 Signature



MARINE BEACH ROUTINE ON-SITE SANITARY SURVEY METHODS

PART I – GENERAL BEACH CONDITIONS

Air Temperature: Liquid-in-glass thermometer Electronic thermometer Weather report from local airport
 Weather report from local weather station Other (describe): _____

Wind Speed and Direction:
 Wind vane for direction Wind sock for direction and speed Anemometer for wind speed
 Aerovane for wind direction and speed Weather report from local airport Weather report from local weather station
 Other (describe): _____
 Distance from station: _____ (ft / mi)

Weather Conditions: Visual observations Other (describe): _____

Rainfall: Rain gauge Weather report Other (describe): _____

Distance from station or gauge: _____ (ft / mi)

Longshore Current Speed: Stick with fishing reel with water balloon on end Ball and tether
 Other (describe): _____

Wave Height: Visual examination of wave height Graduated stick and ranging pole
 Other (describe): _____

Tidal Phase: Visual examination Weather report (source: _____) Other (describe): _____

Rip Currents: Visual examination Weather report (source: _____) Other (describe): _____

PART II – WATER QUALITY

Water Temperature: Multiprobe Electronic meter Graduated thermometer Report from local radio station
 Report from NOAA weatherband radio Other (describe): _____

Turbidity: Simple visual observation Visual test kit Titrimetric test kit Nephelometer/Turbidimeter
 Other (describe): _____

Salinity: Multiprobe Salinity meter Conductivity meter Other (describe): _____

DO: DO meter Multiprobe Other (describe): _____

PART III – BATHER LOAD

Numbers of People Participating in Various Activities: Counting by surveyor Counting by lifeguards Photos
 Turnstiles Other (describe): _____



MARINE BEACH ROUTINE ON-SITE SANITARY SURVEY METHODS (continued)

PART IV – POTENTIAL POLLUTION SOURCES

Sources of Discharge:

(a) Source identification: Visual observation WWTP Notification/Report Other (describe): _____

(b) Flow/velocity or Volume measured: Mechanical flow meter Electric flow meter USGS Gauging Station WWTP Notification/Report Orange (float) and stopwatch Other (describe): _____

Tide Pools: _____ Describe how size was estimated: _____

Floating Present: Visual observation Cleanup event results Other (describe): _____

Amount and Type of Beach Debris/Litter on Beach: Visual observation Cleanup event results Other (describe): _____

Harmful Algal Bloom: Visual observation Other (describe or list source): _____

Algae in Nearshore Water and Beach:

(a) Amount and Color: Visual observation Other (describe): _____

(b) Identification: Field guide or internet site for taxonomic identification (describe): _____ Other (describe): _____

Presence of Wildlife and Domestic Animals: Counting using hand-held counter, and if necessary, binoculars Other (describe): _____

Dead birds:

(a) Number: Visual observation Other (describe): _____

(b) Identification: Field guide or internet site for taxonomic identification (describe): _____ Other (describe): _____

Dead fish:

(a) Number: Visual observation Other (describe): _____

(b) Identification: Field guide or internet site for taxonomic identification (describe): _____ Other (describe): _____

B.2: Chain of Custody Form



SGS NORTH AMERICA INC. CHAIN OF CUSTODY RECORD

SGS Environmental Services
200 West Potter Road
Anchorage, AK 99518
(907) 562-2343
www.sgs.com/ak/akla

Page 1 of 1

INSTRUCTIONS: SECTIONS 1-5 MUST BE FILLED OUT. OMISSIONS MAY DELAY THE ONSET OF ANALYSIS.

SECTION 1					SECTION 3		PRESERVATIVE						
CLIENT:	ABC Consultin				#	SAMPLE TYPE	NaOH/C	NaOH/C	NaOH/C	HCl/C	HCl/C	HCl/C	
CONTACT:	John Smith		PHONE #:	(907)555-1234									
PROJECT NAME:	123 Park Street		PROJECT# / PERMIT #:										
REPORTS TO:	John Smith		E-MAIL:	John.Smith@abc.com									
INVOICE TO:	ABC Consulting		QUOTE #:	13244									
P.O. #:	2015-005				CONTAINER	M (Multi-increments)							
RESERVED FOR LAB USE	SAMPLE IDENTIFICATION	DATE MM/DD/YY	TIME HH:MM	MATRIX/MATRIX CODE	#	TYPE	SW82700 - SEM/ANALYST/103 - PAH/DR/DRD	SW82600/101 - VOC/GRD	SW82700 SEM - PAH	AK102/103 - DR/DR/DRD	SW82600B - VOC	AK101 - GRO	REMARKS/LOC ID
	032015-001	3/19/2015	12:00	Soil	2	Grab	<input checked="" type="checkbox"/>	<input checked="" type="checkbox"/>					
	032015-002	3/19/2015	12:05	Soil	2	Grab	<input checked="" type="checkbox"/>	<input checked="" type="checkbox"/>					
	032015-003	3/19/2015	12:10	Soil	2	Grab	<input checked="" type="checkbox"/>	<input checked="" type="checkbox"/>					
	MW-001	3/19/2015	12:15	Water	10	Grab			<input checked="" type="checkbox"/>	<input checked="" type="checkbox"/>	<input checked="" type="checkbox"/>	<input checked="" type="checkbox"/>	
	MW-002	3/19/2015	12:20	Water	10	Grab			<input checked="" type="checkbox"/>	<input checked="" type="checkbox"/>	<input checked="" type="checkbox"/>	<input checked="" type="checkbox"/>	
	MW-003	3/19/2015	12:25	Water	10	Grab			<input checked="" type="checkbox"/>	<input checked="" type="checkbox"/>	<input checked="" type="checkbox"/>	<input checked="" type="checkbox"/>	
	Trip Blank	3/19/2015	12:00	Soil	1	NA		<input checked="" type="checkbox"/>					
	Trip Blank	3/19/2015	12:15	Water	6	NA					<input checked="" type="checkbox"/>	<input checked="" type="checkbox"/>	
SECTION 5		SECTION 4		SECTION 4		SECTION 4							
RELINQUISHED BY: (1)		DATE	TIME	RECEIVED BY:		DOD Project? NO		DATA DELIVERABLE REQUIREMENTS					
RELINQUISHED BY: (2)		DATE	TIME	RECEIVED BY:		COC ID:		Level 2 / DataView					
RELINQUISHED BY: (3)		DATE	TIME	RECEIVED BY:		Cooler ID:		REQUESTED TURNAROUND TIME AND/OR SPECIAL INSTRUCTIONS					
RELINQUISHED BY: (4)		DATE	TIME	RECEIVED FOR LABORATORY BY:		TEMP BLANK °C:		CHAIN OF CUSTODY SEAL: (CIRCLE)					
						OR AMBIENT []		INTACT BROKEN ABSENT					
						(See attached Sample Receipt Form)		(See attached Sample Receipt Form)					

<http://www.sgs.com/terms-and-conditions>
 F101_eCOC_Revised_2014-12-18

B.3: Statement of Qualifications

B.4: Sampling Location Maps

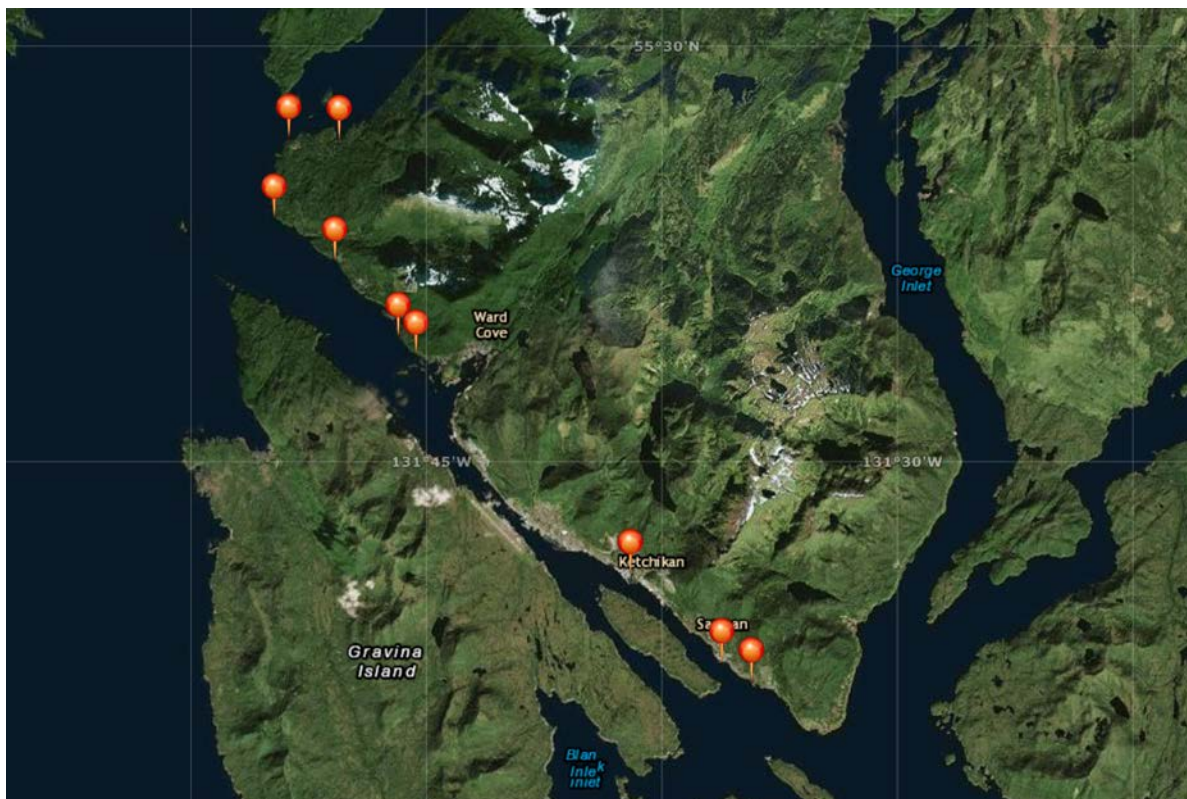



Beach Monitoring Handbook

Ketchikan, AK

Alaska Beach Program Contact Information

DEC BEACH Project Manager - Gretchen Pikul

Phone: (907) 465-5023

Email: gretchen.pikul@alaska.gov

DEC BEACH Quality Assurance Officer - Douglas Kolwaite

Phone: (907) 465-5305

Email: douglas.kolwaite@alaska.gov

R&M Engineering, Inc.

6355 Carlanna Lake Road

Ketchikan AK 99901

(907) 225-7917 phone; (907) 225-3441 fax

July 2017

Alaska's Marine Water Quality Indicator Criteria for Bacteria

Enterococci

Enterococci	
Statistical threshold value	Not more than one sample, or more than 10% of the samples if there are more than 10 samples, may exceed a statistical threshold value of 130 enterococci (cfu/100 mL)
Geometric mean	In a 30-day period, the geometric mean of samples may not exceed 35 enterococci (cfu/100 mL)

Beach-Monitoring Handbook

This handbook introduces the DEC Beach Monitoring Program. The goal of the program is to reduce or eliminate illness and disease due to contact with water at recreational-use beaches that are contaminated by human and animal waste (fecal pollution).

This handbook was designed to provide you with simple instructions for beach assessments, water-quality sampling, and public notification in the event recreational water becomes contaminated with fecal pollution. The book is divided into four main sections.

Section 1 provides background information about the Alaska Beach Program, disease-causing organisms (Pathogens) and their indicators, and state and federal water-quality standards.

Section 2 gives you information about how to assess the risk of exposure to fecal contamination at beaches in your area. This section includes detailed information about how to collect, handle, and ship water samples for laboratory bacterial analysis, as well as how to conduct a beach survey.

Section 3 tells you whom you should notify when your beach assessment indicates marine water quality is unsafe for water-contact activities. It also provides information about how best to notify the public about the water quality at your beach(es).

Section 4 provides water sampling protocols and example field forms, press releases and signage.

Table of Contents

Beach-Monitoring Handbook.....	2
Table of Contents	3
Section 1 - Background.....	5
National BEACH Monitoring Program	5
Alaska BEACH Program	6
Grant Specific BEACH Information.....	7
Ketchikan BEACH Monitor Responsibilities	7
DEC BEACH Project Manager Responsibilities	8
Water Quality Standards (WQS).....	10
EPA’s Water Quality Standards	10
Alaska’s Water Quality Standards.....	10
BEACH Program.....	10
Section 2 – Community Beach Assessments	12
Overview.....	12
Beach Survey Field Form.....	12
Beach Survey Schedule and Locations.....	13
Community Beach Sampling.....	14
Sample Chain of Custody	14
Laboratory Responsibilities.....	15
Preliminary Quality Assurance/Quality Control (QA/QC) Review of Beach Sample Data	15
Communicating with DEC	17
Re-Sampling.....	17
Section 3 – Notifying the Public.....	19
Beach Advisory	19
Beach Signs	20
Fact Sheets or Flyers.....	20
Press Release	20
Section 4: Protocols and Example Forms	21
Water Sampling Collection Protocols.....	21
Water Sample Collection	21
Sample Collection Method.....	21
Sample Handling	23
Example Forms	25

Example Beach Sampling Field Form25

Example Beach Advisory Sign28

Example DEC Press Release29

DEC Approved Labs for Drinking Water.....30

Section 1 - Background

Nationwide the greatest cause of coastal water quality impairment is bacteria.¹

Beaches are a valuable recreational resource in Alaska. They provide access to coastal recreation waters for swimming, surfing, fishing, playing, and many other water-contact activities. Alaskans do not limit their recreational activities to sandy beaches; gravelly, rocky, or mud-covered beaches are commonly used for recreation. What Alaskans may not know is that recreational activities involving water contact could make them sick if the water is contaminated with human or animal waste (e.g., sewage or other sources of fecal pollution).

A wide variety of sources can contribute to the presence of pathogens associated with fecal pollution in coastal areas. While some of the sources may be direct of “point” sources (e.g., discharge from a waste water treatment plant), others may be “nonpoint” sources which are much harder to track (e.g., failing septic systems).

As rain washes over a watershed, it has the ability to gather pathogens from a number of different sources. Numerous sources makes the process of ruling out whether it is human related or not difficult. In many cases, birds, wildlife, and algae have been linked to being the sources of high levels of fecal bacteria.

People may get sick from recreating in water near possible fecal pollution sources, such as:

- sewage lagoons
- honey-bucket dumps
- sewage treatment plants
- septic tanks and leach fields
- small boats
- storm-water runoff
- landfills
- wildlife

Water contaminated with fecal pollution may contain disease-causing microbes (pathogenic bacteria, viruses, and protozoa). If people are directly exposed to or ingest this pollution, it can cause stomach aches, diarrhea, or ear, eye and skin infections. Water-quality monitoring at beaches near fecal-pollution sources can reveal conditions that indicate an elevated risk of becoming ill from water contact.

National BEACH Monitoring Program

The U.S. Environmental Protection Agency (EPA) developed the concept of a Beach Sanitary Survey as a means for providing State and local beach managers with a technologically sound and consistent approach to identify pollution sources and share information.² The survey tool provides a method for documenting historic as well as current records of beach and watershed water quality. It provides baseline information including land use, water quality, and pollutant source data. The survey document is meant to serve as a living record that is

¹ US EPA. 2002. National Water Quality Inventory 2000 Report. EPA-841-R-02-001. Washington DC: Environmental Protection Agency.

² US EPA. 2008. Great Lakes Beach Sanitary Survey User Manual. EPA-823-B-06-001 Washington DC. Environmental Protection Agency.

regularly updated and evaluated. The survey can be broken into two formats; routine and annual sanitary surveys, in order for temporal data to be evaluated in a more organized manner. The survey information is used by the Alaska Department of Environmental Conservation (DEC) to prioritize beaches for monitoring and assist in development of models to predict daily bathing beach water quality, if appropriate. The survey also provides support for enforcement actions as it establishes a record of conditions and changes over time. The Beach Sanitary Survey assists beach managers meet the requirements of the BEACH Act Grant Program, as described in the National Beach Guidance and Required Performance Criteria for Grants (USEPA 2002b).

Alaska BEACH Program

In response to the increasing incidence of water-borne illness at public beaches, the U.S. congress passed the Beaches Environmental Assessment and Coastal Health (BEACH) Act of 2000. The Act provides support for state programs to reduce the risk to beach users from contact with fecal contaminated water.

The Act authorized the EPA to award grants to states, and the DEC Division of Water (DOW) has used these grants to create an Alaska BEACH Program.

To date, the Alaska BEACH Program has:

- Defined many of the unique aspects of Alaskan recreational beach use;
- Sent surveys to Alaskan coastal communities to assess the likelihood of fecal pollution at their beaches;
- Used the survey data to rank beaches according to their potential exposure risk;
- Developed a generic beach-monitoring plan;
- Developed a generic risk-communication plan; and
- Conducted pilot water-quality sampling at some Alaskan beaches the community surveys identified as having risks of fecal pollution.

The DEC encourages communities to create local beach-monitoring programs and work with the DEC in notifying the public if there is an elevated risk of becoming ill from the water. Local management of water-sampling and public-notification programs should provide the most effective means of protecting the community from exposure to disease-causing organisms in human and animal waste.

Disease-causing organisms come from a variety of sources and can be fairly complicated to track and monitor. As a result of this, the DEC has developed a BEACH Sanitary Survey, based on EPA's survey tool, to assign levels of risk in coastal areas where recreational activity takes place, to aid in the identification and remediation of pollution sources, and to protect marine water quality on Alaska's beaches. Use of surveys is just one part of a larger effort to protect water quality through appropriate and relevant management activities. The BEACH Monitoring process includes, and is not necessarily limited to:

- An initial risk assessment of the coastal area of concern;

- Development or improvement of a water quality monitoring plan specific to a particular area;
- A notification plan to communicate levels of risk to the public;
- Conducting a sanitary survey on a routine basis;
- Means for measuring and monitoring results;
- Cooperation amongst land owners and resource managers to resolve or mitigate issues;
- Metrics to measure improvements over time; and
- Increases public awareness and cooperation in controlling water pollution.

The Alaska Beach Program follows requirements set out in the 2014 National Beach Guidance and Required Performance Criteria for Grants.

Grant Specific BEACH Information

Every BEACH grant program requires the development of a formal relationship with the landowner of the beach being proposed for monitoring. The Ketchikan Indian Community (KIC) and the City and Borough of Ketchikan agree with the DEC to develop a local beach monitoring program, with the goal of protecting beach users from exposure to water contaminated by fecal pollution. The Ketchikan BEACH Monitoring Program receives support from the DEC in the form of training, limited funding for water-quality sampling, Standard Operating Procedures for sampling, a Quality Assurance Project Plan template, and a database template for data storage and sharing.

The Ketchikan BEACH Monitoring Program will consist of local individuals periodically conducting beach assessments and collecting water-quality samples for laboratory analysis. Their work will be coordinated by the Ketchikan BEACH Monitor who will keep in touch with the DEC BEACH Project Manager to keep her informed about sampling events.

The roles and responsibilities of the Ketchikan BEACH Monitor and DEC BEACH Project Manager are described in this section. Details about conducting sanitary surveys, collecting and shipping samples, and notifying the public about sample results are given in **Section 2** (Community Beach Assessments) and **Section 3** (Notifying the Public) of this handbook. Figure 1 shows a flow chart describing roles in project organizational structure. In many cases, it is likely that one person may fill more than one role.

Ketchikan BEACH Monitor Responsibilities

The main roles and responsibilities of the Ketchikan BEACH Monitor are to:

- Conduct beach assessments;
- Collect water-quality samples;
- Ship samples to a laboratory for bacterial analysis; and
- Notify the DEC and respective land owner in the event that water samples exceed acceptable bacteria limits.

The Ketchikan BEACH Monitor data analysis responsibilities include:

- Sending beach-sampling and sample identification information to the DEC BEACH Project Manager and DEC Quality Assurance Officer;
- Reviewing laboratory data results to ensure required Quality Assurance/Quality Control (QA/QC) criteria have been met;
- If QA/QC criteria have not been met, the Ketchikan BEACH Monitor will notify the DEC project manager as soon as possible, and in consultation with DEC and other affected parties, develop a corrective action plan to resolve the problem/s;
- Comparing the laboratory results to Alaska and EPA water-quality standards;
- Conferring with the DEC BEACH Program Manager regarding water-quality standard exceedances and the possible need for re-sampling; and
- Submitting laboratory data to the DEC, after completing QA/QC protocols, using DEC provided template or DEC approved format.

DEC BEACH Project Manager Responsibilities

The roles and responsibilities of the DEC BEACH Project Manager are to:

- Provide recommendations to Ketchikan for BEACH survey activities;
- Provide recommendations to Ketchikan for water-quality monitoring;
- Assist with water-quality data assessment;
- Work with the land owner to notify the general public of an exceedance following re-sampling and data assessment, and;
- Report beach-assessment and sampling data to the EPA.

The DEC BEACH Project Manager is also responsible for keeping a record of activities associated with sampling events. This record will include information on the dates, locations, samplers, and results of the monitoring, and will be used to compile an annual report to the EPA on recreational beach water quality for Alaska.

Most important, the DEC BEACH Project Manager will have lead responsibility in working with the municipality or responsible landowner to develop a public notice and other press-related information advising the public of the risks from marine water when beach sampling results exceed State or federal Water Quality Standards.

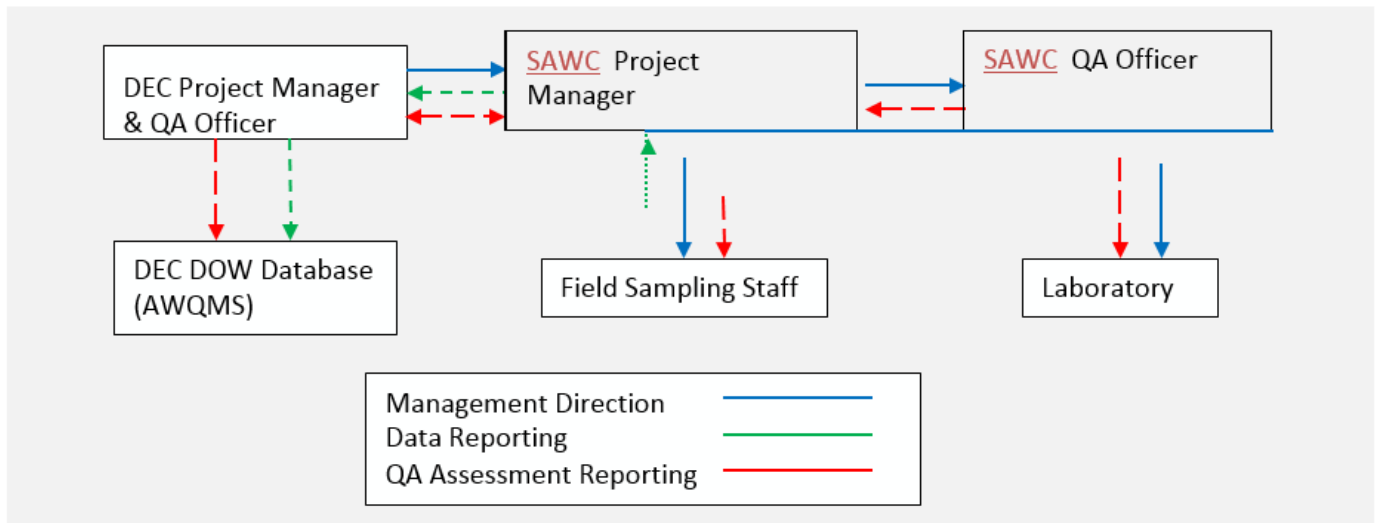

Figure 1: Project Organizational Structure

Water Quality Standards (WQS)

The BEACH program is concerned with fecal contamination. Bacteria can indicate the presence of fecal contamination, which itself may harbor disease-causing (pathogenic) microbes. The indicator bacteria most commonly used are called coliforms and enterococci. Federal and State Water Quality Standards (WQS) set limits for these parameters. Laboratory testing for the presence and abundance of these bacteria is required.

EPA's Water Quality Standards

The EPA recommends the use of enterococcus bacteria, or enterococci (pronounced ěn'tĕ-rĕ-kĕk'sĭ) as indicators of fecal pollution in marine water. Enterococcus bacteria are found in the human intestine. They are subgroup of the fecal streptococci. Studies indicate that the enterococci portion of the streptococcus group is the most efficient bacterial indicator of fresh and marine water quality.

As allowed under Criterion 10 of the EPA, July 2014, National Beach Guidance and Required Performance Criteria for Grants, Alaska has proposed and received an alternative Beach Action Value (BAV). Alaska's proposed BAV is equal to the EPA's 2012 Recommended Recreational Water Quality Criteria's Statistical Threshold Value (at the 36 per 1000 recreators' illness rate) of 130 CFU/100 ml (EPA-832-B-14-001). The 130 CFU/100 ml value corresponds to the 90th percentile of the water quality distribution associated with the same level of public health protection (in this case, 36 per 100 recreators').

Alaska's Water Quality Standards

The State of Alaska's water quality standard also uses enterococcus bacteria as indicators of fecal pollution in marine water for recreational use.

Alaska's water quality standard for pathogen indicators states, "in a 30-day period, the geometric mean of samples may not exceed 35 enterococci CFU/100 mL, and not more than 10% of the samples may exceed a statistical threshold value (STV) of 130 enterococci CFU/100 mL." This standard for enterococci bacteria is provided in the Alaska Administrative Code 18 AAC 70 for marine water contact recreation. Enterococci bacteria must be determined by the membrane filter technique or Most Probable Number procedure as detailed in Standard Methods for the Examination of Water and Wastewater (American Public Health Association), or by other methods approved by the DEC and EPA. The Alaska standard is tabulated below (Table 1), and on the cover of this handbook.

BEACH Program

The Alaska BEACH Program will monitor both types of bacteria against WQS set for Marine Water Recreation- contact recreation (Table 1; 18 AAC 70 amended February 5, 2017). For the EPA WQS, the DEC has determined that Alaska's beaches are generally in the "lightly used" category; therefore, the DEC has adopted the single-sample standard of 130 enterococci per 100 mL for the BEACH program. In

addition, the geometric mean of five samples collected within a 30-day period may not exceed 35 enterococci per 100 mL.

Alaska’s Marine Water Quality Indicator Criteria for Bacteria	
Enterococci	
Statistical threshold value	Not more than one sample, or more than 10% of the samples if there are more than 10 samples, may exceed a statistical threshold value of 130 enterococci (cfu/100 mL)
Geometric mean	In a 30-day period, the geometric mean of samples may not exceed 35 enterococci (cfu/100 mL)

Table 1: Marine Water-Quality Indicator Standards

Section 2 – Community Beach Assessments

Overview

A Sanitary Survey is a type of beach assessment used to identify sources of pollution. It can be an effective tool for protecting human health at recreational-use beaches by providing information that can be used to design future or modify existing monitoring programs. The Ketchikan BEACH Monitor should conduct surveys in suspected high-risk areas to confirm the presence or absence of fecal pollution. An Annual Survey should be conducted on all newly nominated beaches as well as the beginning of each season of on-going monitoring projects to document seasonal changes or new sources. Routine Surveys will be completed when a sample is collected for water-quality testing. Routine surveys are completed using the BEACH Survey Field Form provided in Section 4.

Annual BEACH Surveys collect information from area maps and land use plans, annual and seasonal trends, coastal geomorphic information, and additional potential sources of pollution at a watershed or sub-watershed level. In some cases Annual BEACH Surveys may be conducted at the end of a sampling season to determine whether changes to the monitoring program should take place in the following year. Information that should be considered during the survey process include:

- Freshwater inputs (river mouth, stream, storm drains);
- Properties with subsurface wastewater disposal systems;
- Significant wildlife habitat/wetlands;
- Agricultural operations;
- Impervious surfaces;
- Marinas/moorages/anchorages;
- Recreational areas and the availability of facilities (restrooms, trash cans, doggie bag disposal stations).

A Routine BEACH survey is conducted by visiting a beach of concern to answer questions and fill in blanks on the BEACH Survey Field Form. Since fecal coliform bacteria may originate from sources other than humans, the assessment will note the number of birds, dogs or other animals on the beach. Debris, vegetation, tide stage and murky water are also noteworthy. If animal waste sources are identified, Ketchikan Project Managers should discuss their observations with the DEC BEACH Project Manager as soon as possible. The survey may include collecting a water quality sample if the DEC BEACH Project Manager and Ketchikan Project Manager decide that beach users may be exposed to fecal pollution.

Beach Survey Field Form

The BEACH Survey Field Form is a data sheet used for collecting field information as part of the Routine and Annual BEACH survey process. It is designed to gather information that the Ketchikan BEACH Monitor and the DEC BEACH Project Manager can use to make annual and routine comparisons of

physical characteristics. It documents the physical conditions present during sampling events. These forms will be created and managed in a manner that will facilitate easy data entry into the Ambient Water Quality Monitoring System (AWQMS).

The BEACH Survey Field Form is made up of three parts:

1. The first part asks for a description of the beach including its location and the name of the person performing the assessment.
2. The second part asks for details about the water quality sample, if collected. These details include date, time sample number(s), and water temperature. The water temperature is determined by using a calibrated thermometer that reads to 0.1 degree centigrade (0.1°C). Record the temperature to 0.1°C. It is very important to allow time for the thermometer to stabilize before writing down the temperature reading.
3. The third part asks for information about the condition of the beach at the time of the assessment including the weather, levels of activity, and potential pollution sources.

To complete a BEACH survey, field staff must fill out all of the information on the Beach Survey Field Form including a sketch map of the sampling location. An example Beach Survey Field Form is located in Section 4.

Beach Survey Schedule and Locations

The Ketchikan BEACH Monitor should conduct BEACH surveys using the BEACH Survey Field Form at designated locations at the beginning of the sampling season and each time a water sample is collected for water-quality testing. These observations can help the Ketchikan BEACH Monitor and the DEC BEACH Project Manager assess changes from year to year and modify the existing monitoring program by identifying times during the season with the highest risk of people getting sick from water contact.

The Ketchikan BEACH Monitor may also conduct BEACH surveys at other suspected high-risk beaches to identify any persistent problems that may warrant a need for water-quality testing. The information gathered can be used by the Ketchikan BEACH Monitor and the DEC BEACH Project Manager to design future monitoring programs to protect human health during the recreation season.

Sampling location data should be collected using a calibrated GPS unit to ensure accuracy. All latitude/longitude data should be collected and recorded in decimal form (12.3456) using the Horizontal Collection System datum NAD83. All future sampling events should take place within 100 feet of that site unless the DEC BEACH Project Manager and Ketchikan BEACH Monitor determine that the site does not accurately represent background conditions of beach water quality.

Community Beach Sampling

The Ketchikan BEACH Monitor will determine the sampling location and schedule in coordination with the DEC BEACH Project Manager. Once a sampling site has been determined, Project and Sampling Location ID numbers will be provided by the DEC BEACH Project Manager to ensure that the site has an EPA assigned PRAWN code and consistent with the AWQMS template. Generally, the Ketchikan BEACH Monitor will collect samples on a weekly basis over a one month period, unless monitoring indicates that Alaska's or EPA's water quality standards are exceeded. Currently, the plan is to collect at least one sample per week at a location where people get in the water unless physical conditions and prior sampling dictates a more rigorous sampling regime.

Samples must be sent to a laboratory that is approved by DEC for Fecal Coliform Bacteria (Method 9222D) and Enterococci by MPN (Method ASTM D-6503-99). Fecal coliform bacteria are collected for comparison to other Alaska WQS designated uses in marine water, such as harvesting for consumption and aquaculture. A list of approved laboratories is attached at the end of this handbook (Appendix A). This list is updated periodically by DEC staff and found by visiting the DEC website (<http://dec.alaska.gov/applications/eh/EHLabStatus/MicroReport/Index>).

The sample collection should follow the tide/sampling schedule provided by the DEC BEACH project manager to target low tides, and be transported to the DEC-approved laboratory within the 6-hour sample holding time. The Ketchikan BEACH Monitor will need to coordinate with the laboratory to make sure someone is at the laboratory and able to process the samples as soon as they arrive.

Sample Chain of Custody

The sample chain of custody form documents actions taken to ensure that samples are traceable from the time they are collected at the beach to the time the analytical laboratory reports the results. The laboratory usually supplies these forms with their field sampling kit. Generally, a completed chain-of-custody form will identify the samples, request analysis from the laboratory, note any special instructions, and document who handled the samples from the time they were shipped from the field to the time they reach the laboratory. The Ketchikan BEACH Monitor is responsible for filling out the chain-of-custody form and keeping a copy for reference. The form must include the following information:

- Name and contact information of the person taking the samples;
- Sample identification, including the sample number, and date and time the sample was collected;
- The sample preservation method/s;
- The type of sample (e.g., water sample, sample replicates, field and temperature blanks) and the number of jars being submitted for analysis;
- The requested analysis (enterococcus and fecal coliform bacteria);
- The requested turn-around time (Note: the laboratory is requested to analyze the samples and present the results within 36 hours of sampling);

- Name and contact information for delivery of results (Note: the results should be sent to the DEC BEACH Project Manager and the Ketchikan BEACH Monitor; and
- A relinquishment signature including printed name, date and time.

In addition to completing the chain-of-custody form the Ketchikan BEACH Monitor needs to:

1. Put the completed chain-of-custody form into a plastic bag taped to the inside lid of the cooler;
2. Attach two completed chain-of-custody seals (stickers) to cross over the cooler lid seams;
3. Attach a clearly marked label with laboratory contact information on the top of the sample cooler;;
4. Hand deliver the samples to the airlines;
5. Keep a copy of the airlines' transportation documentation or other means of delivery for reference;
6. Contact the courier service to ensure pick-up and delivery of sample;
7. Contact the laboratory, again, to verify that someone will be there when the samples arrive; and
8. Fax or email a copy of the BEACH Survey Field Form to the DEC BEACH Project Manager.

Laboratory Responsibilities

The Ketchikan BEACH Monitor will work with the pre-determined laboratory to complete analysis of samples and data submission. Laboratories are responsible to comply with the data quality objectives specified in the QAPP and as specified in the laboratory QAP and method specific Standard Operating Procedures (SOPs). Validated sample laboratory data results are reported to the Ketchikan BEACH Monitor and DEC BEACH Project Manager. Electronic project data will be stored on a secure computer or on a removable hard drive that can be secured. All records will be retained by the contract laboratory for five years.

Preliminary Quality Assurance/Quality Control (QA/QC) Review of Beach Sample Data

When the Ketchikan BEACH Monitor receives sample results from the laboratory, the results need to be compared to the marine Water Quality Standards that are referenced in Section 1 of this handbook. The Ketchikan BEACH Monitor should check to make sure the sample was analyzed within the 6 hour holding time and that the temperature was within the allowed range when the samples were received at the laboratory. Secondary reviewers (sampling coordinator/supervisor/project supervisor) are responsible for the review, verification and validation of field and laboratory data and data reformatting as appropriate for reporting to AWQMS. The secondary reviewer is also responsible for reporting validated data to the DEC Project Manager. The data management task will include keeping accurate records of field and laboratory QA/QC samples so that project managers and technical staff who use the data will have appropriate documentation to show that the required minimum data quality standards have been met.

The DEC DOW Project Manager, DEC QA Officer and AWQMS data entry staff conduct final data reviews (tertiary review) and submits the validated data to AWQMS. See the flow chart in Figure 2 for detailed information on data management responsibilities.

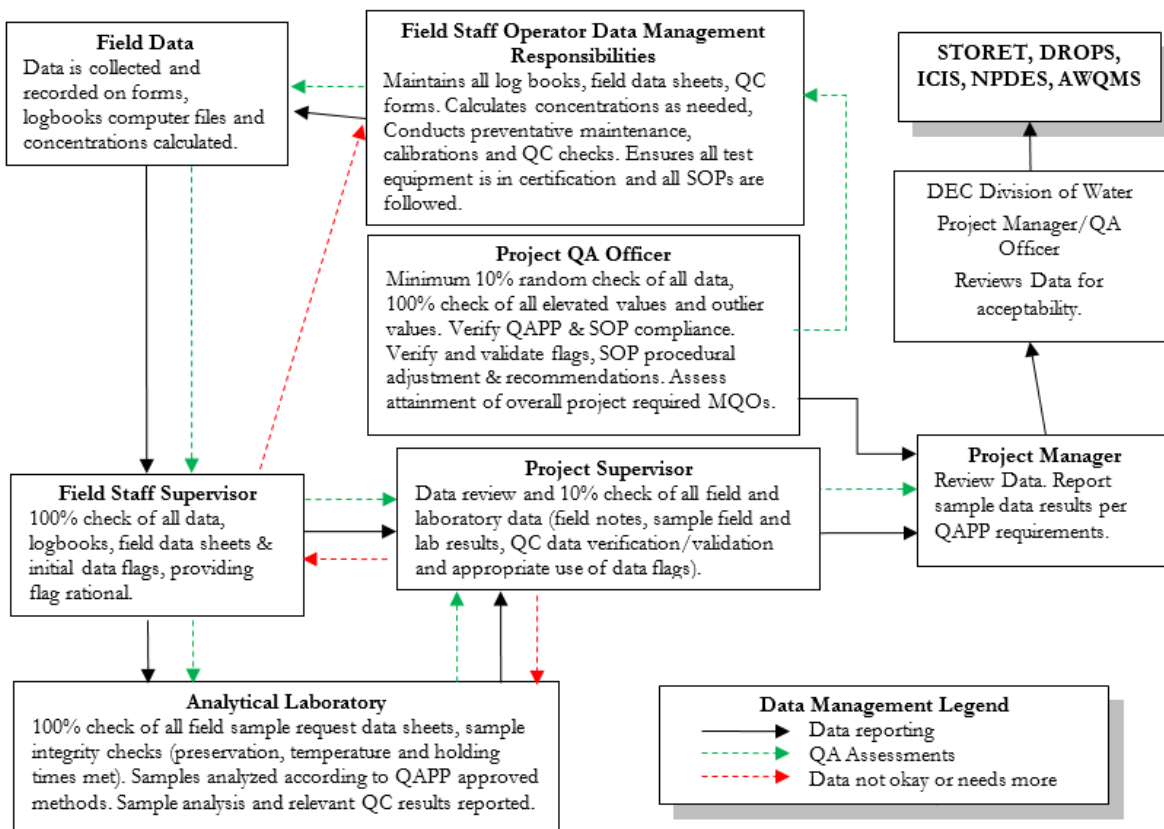

Figure 2: Data Management Flow Chart

Figure 2: Data Management Flow Chart

Communicating with DEC

After collecting and shipping samples to the laboratory, the Ketchikan BEACH Monitor will let the DEC BEACH Project Manager know that the samples are on their way to the lab, and send the completed BEACH Survey Field Form.

After reviewing the sampling results from the laboratory, the Ketchikan BEACH Monitor will need to talk to the DEC BEACH Project Manager to decide if additional sampling or public notification procedures should be initiated.

Re-Sampling

If a sample, after undergoing quality assurance review, is found to exceed BEACH program Water Quality Standards (WQS; Table 1), the Ketchikan BEACH Monitor is required to initiate an additional sampling event to confirm that the exceedence is an on-going issue (See Figure 3). Re-sample protocols will be consistent with those of routine events. If the re-sample event determines that the exceedence is on-going, a Beach Advisory (see Section 3) will be issued by the landowner and DEC. Routine sampling events will continue according to schedule and the Beach Advisory will remain in place until samples are below WQS.

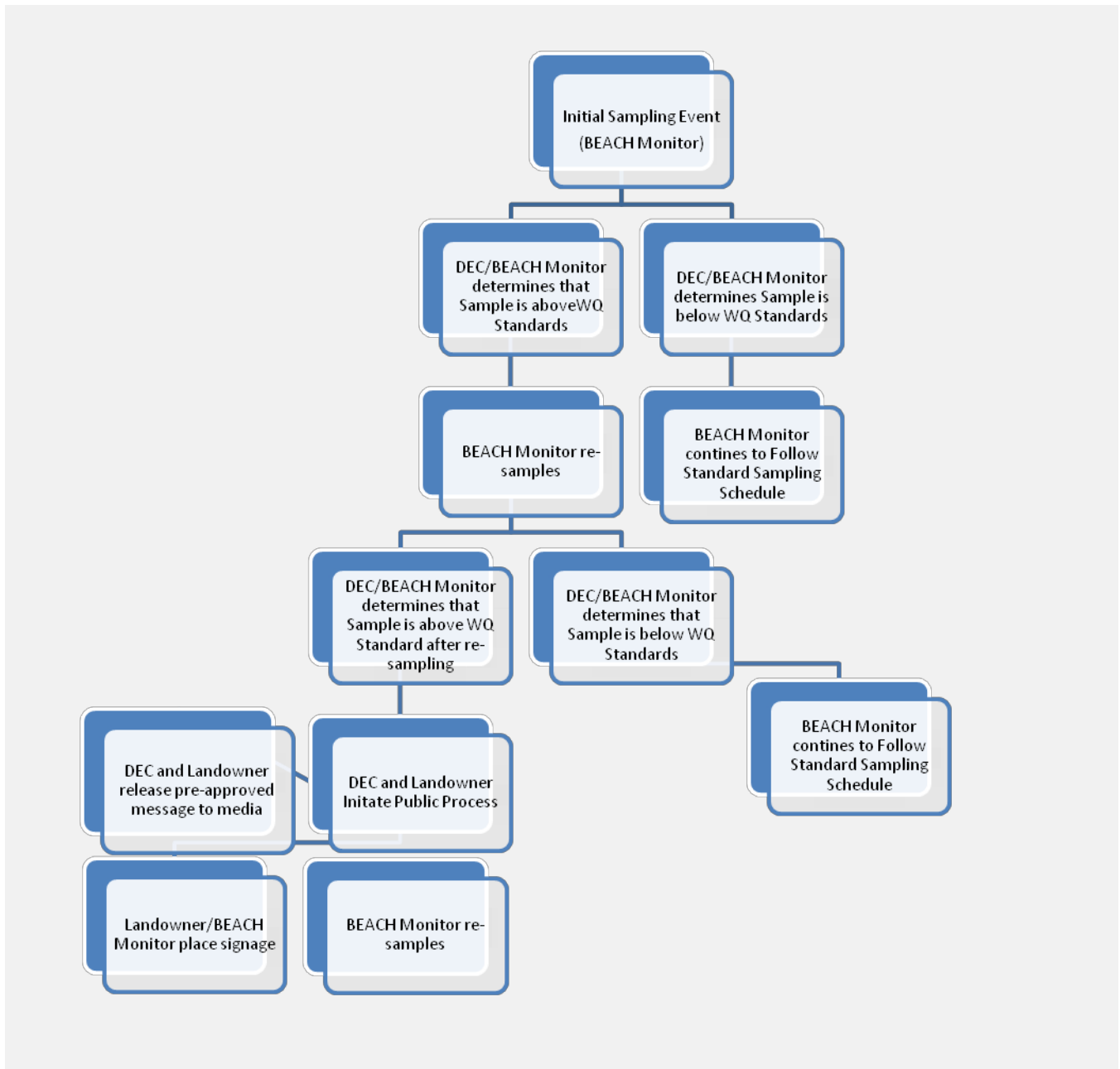

Figure 3: Sample Decision Tree

Section 3 – Notifying the Public

Communicating with the public regarding the nature of the BEACH program, sampling results, and potential responses to Water Quality Standards exceedances is very important. The DEC will work with the respective land owner to distribute public information about sampling results that may require actions such as a Beach Advisory or Beach Closure. Communication plans and specific actions taken will be developed between the DEC, landowner (s) and the BEACH Monitor on a case by case basis.

Beach Advisory

DEC recommends an advisory be issued to the public that warns of health risks from recreation in coastal water when beach-sampling results indicate potential fecal bacteria contamination. The advisory will be based on the bacterial counts and the information from the Beach Survey Field Form.

A Beach advisory provides recommendations to the public to avoid swimming in water that has exceeded the marine WQS referenced in Section 1 (Table 1) of this handbook. Sampling events are scheduled to take place throughout the recreational season. If a sample demonstrates an exceedance for enterococci bacteria, a re-sampling event will be triggered to verify that the presence of the bacteria is ongoing. A Beach Advisory may be issued by the respective land owner and DEC upon receipt of water quality re-sampling results that demonstrate a continued exceedance of water quality standards for bacteria.

The advisory should include:

- General heading (“ADVISORY” or “WARNING”);
- Reason for the advisory;
- Time of the advisory;
- Duration of the advisory;
- Location of the affected beach; and
- Number to contact local beach manager for further information.

Advisories should be issued in the form of press releases, signs at the affected beach, and fact sheets (informative flyers). The DEC will act as the lead in developing advisory information and signage. The press releases should be distributed to local media outlets, government offices, and emergency response entities, and advisory signs should be posted at the beach until additional assessments (sampling) indicate the water quality is acceptable. Contacts for public notification should be developed and verified at the beginning of each season. Table 2 is a framework for organizing possible contacts.

Table 2: Contacts for Public Notification during a Beach Advisory

Community Entity	Contact Person	Phone Number	Email Address
Radio Stations	KRBD	(907) 225-9655	
	KFMJ	(907) 247-3699	
	KTKN	(907) 225-2193	
Newspaper	Ketchikan Daily News	(907) 225-3157	http://www.ketchikandailynews.com/contact_us/
City Manager	Ruben Duran	(907) 228-6625	managersoffice@kgbak.us
Borough Manager	Karl Amylon	(907) 2285-5603	karla@ktn-ak.us
Police Department		(907) 225-6631	
Fire Department		(907) 225-9616	

These media outlets, local governments and emergency response entities can initiate their existing communication protocols to notify the public of potential health risks at the local beach(es). A standard-format press release public service announcement is included in Section 4.

Beach Signs

If a re-sampling event has been triggered and water quality standards continue to show exceedances, a sign should be posted at major beach access points to alert beach users of their risk of illness from water-contact recreation. A sign should also be posted on the beach near the location where the fecal contamination was detected so recreational users know it is not safe to swim there. This advisory should recommend that the public avoid water contact activities at the beach until further analyses reveal safe conditions. Signs will be in place until re-sampling determines that water quality standards are being met. An example of a Beach advisory sign is located in Section 4.

Fact Sheets or Flyers

Distributing informative flyers in public areas can also communicate potential health risks to local beach users. A flyer could be used as an advisory by passing out press release information to people in public places. It also could be used to educate the community about the BEACH Project. The Alaska BEACH Program produced a generic one page fact sheet about the BEACH project that answers commonly asked questions. It can be found at the DEC Alaska BEACH Grant Program website by clicking on the “What is BEACH Grant” quick link. The website address is <http://www.dec.state.ak.us/water/wqsar/wqs/beachprogram.htm>.

Press Release

A press release is likely the fastest way to spread the news about water quality at recreational use beaches in Alaskan communities. The DEC and landowner will act as the lead agents in providing public information.

Section 4: Protocols and Example Forms

Water Sampling Collection Protocols

Water Sample Collection

Water sampling involves wading into the water adjacent to a beach commonly used for water recreation to collect water from below the surface into sample jars. The sample should be collected in the general recreational beach area, or near locations expected to be influenced by fecal contamination (e.g., adjacent to sewage lagoons, near small boat harbors, etc.). The Ketchikan BEACH Monitor will complete sampling after the following steps have been accomplished:

- Each sample jar is filled with water;
- Each sample jar is labeled;
- Each sample jar is placed in a cooler kept chilled with artificial ice (artificial ice reduces potential for cross contamination);
- The Beach Survey Field Form is filled out;
- A chain-of-custody form is filled out;
- The cooler is transported to the laboratory responsible for determining fecal coliform and enterococcus populations; and
- A copy of the Beach Survey Field Form and chain-of-custody form is sent to the DEC BEACH Project Manager.

Detailed directions for water sample collection, sample handling and delivery are given in the following subsections.

Sample Collection Method

A good water sample is collected by avoiding cross-contamination, which can happen when the sampler inadvertently contaminates the sample. To reduce the potential for cross-contamination the sampler must follow a standard sample-collection method. Step-by-step sample-collection instructions are provided below:

1. Request a sample kit from the laboratory. The kit should include:
 - A cooler;
 - The appropriate sample bottles for marine water-quality sampling (enterococci and fecal coliform bacteria);
 - Artificial ice to keep the cooler chilled to the appropriate temperature (<10°C);
 - Temperature blank;
 - Chain-of custody form;

- Custody seal;
 - Sample jar labels;
 - An extra set of sample bottles;
 - An extra set of sample bottles for a replicate sample;
 - Shipping labels; and
 - Packing material.
2. **Call the laboratory prior to sampling to make sure there will be someone at the laboratory to receive and process the samples within 6 hours of sampling.**
 3. **If necessary consult flight schedules to make sure there will be a flight that can get the samples to the laboratory within 6 hours of sampling.**
 4. Write the beach sampling location on the bottle label and Beach Survey Field Form.
 5. Put on clean waders and gloves. Wade into the water to a depth of approximately 3 feet. Try to avoid kicking up sediment or wait until any sediment that has been kicked up settles. Stand downstream of the water current and wait for sediment to clear.
 6. Remove the bottle cap just before collecting the sample. Protect the cap from contamination. Do not touch the inside of the bottle, or the inside of the cap.
 7. Open the sampling bottle and hold onto the base with one hand. Plunge the top of the bottle downward into the water. Avoid introducing surface scum. Point the mouth of the bottle into the current. Hold the bottle about one (1) foot below the water surface and tip it slightly upward to allow air to exit and the bottle to fill.
 8. Remove the bottle from the water. Pour out a little water to leave airspace at the top of the jar.
 9. Tightly close each bottle.

Collect one replicate for each analyte per sampling event. To collect a replicate sample, you must first have requested extra bottles from the laboratory. Repeat Steps 2 through 9 at the same location to complete collection of field replicates.

10. Complete bottle labels and attach them to each sample jar. Labels should be clean, waterproof, non-smearing, and large enough for all the information. Information on the label should include:
 - Sample location (e.g., beach name, KB-Rotary)
 - Sampling date and time
 - Laboratory method for analysis
 - Name of sampler
11. When finished sampling, wash your hands and arms with soap and water or waterless antimicrobial cleanser, or disinfectant lotion to reduce exposure to potentially harmful bacteria or microorganisms.

Sample Handling

Sample handling involves packing the samples in a cooler and shipping them to the laboratory. After sample collection is complete the samples must be handled with care so that they arrive to the laboratory in good condition. Step-by-step sample handling instructions are provided below:

1. Place the sample(s) in a pre-chilled cooler containing artificial ice to maintain a temperature from 1° to 10°C. Ask the laboratory ahead of time how much ice will be needed. **Do not allow the samples to freeze. Samples must remain below 10°C until receipt by qualified staff at the laboratory, otherwise samples are determined invalid so ensure sufficient cold artificial ice is added.**
2. Place enough packing material inside the cooler to protect the sample bottles from breaking during transport to the laboratory.
3. Complete the chain-of-custody form. Put the form in a plastic bag and tape it to the inside of the cooler lid.
 - Write a note in the “Special Instructions” box requesting that the laboratory results be sent without delay (within 36 hours of sampling) to three people: Ketchikan BEACH Monitor, DEC BEACH Project Manager, and DEC BEACH Quality Assurance Officer.
4. If the cooler will be out of your immediate control (such as on an airplane or courier), fill out two custody seals and attach one to the front and one to the back of the cooler to span the lid seam. You want them to tear when the cooler is opened.

5. Securely tape the cooler shut prior to shipment. Attach shipping labels that identify the shipping destination and say: “keep cool,” “do not freeze,” and “fragile.”
6. Ship the samples to DEC-certified laboratory R&M Engineering-Ketchikan, Inc. (907) 225-7917.
7. **Remember that samples have to be collected, shipped and received by the laboratory in 6 hours. Consult flight schedules, and call the laboratory prior to sampling to make sure there will be a flight that can get the samples to the laboratory within 6 hours of sampling, and that there will be someone at the laboratory to receive the samples and begin the analyses.**

Example Forms

Example Beach Sampling Field Form

Name of Beach _____ Date _____

Nearest Town _____

Describe Sampling Location (Note location on map and attach) _____

Latitude N _____ Longitude _____

SAMPLES

Sample(s) ID: _____ **Time:** _____

Replicate ID: _____ **Time:** _____

Field Blank ID: _____ **Time:** _____

Weather Conditions:

Sunny & Clear _____ Rain _____
Cloudy / Overcast _____ Fog _____

Other (describe): _____

Water Temperature: _____ °C

Air Temperature: _____ °F °C

Wind Speed (approx): _____ Mph

Wind Direction: _____ On Shore Off Shore

Precipitation in the last 24 hours: _____ in

Tidal Conditions:

Low Tide Ebbing
 High Tide Flooding

<u>Tide</u>	<u>Height</u>	<u>Time</u>
Low:	<input type="checkbox"/> ft <input type="checkbox"/> m	(am/pm)
High:	<input type="checkbox"/> ft <input type="checkbox"/> m	(am/pm)

Condition of the beach:

	Debris (Describe)	Vegetation (% Coverage)
On shore		
In water		

Activity on the Beach

Adults _____ Dogs _____
Children _____
Other
(describe): _____

Type of Activity

Swimmers _____ Walkers _____ Fishermen _____ Boaters _____
Other
(describe): _____

Condition of the Water

Clear Cloudy & Murky Oily Film
 Other
(describe): _____

Potential Sources of Pollution

Water Fowl (approx #): _____ Boats (approx #): _____
 Other
(describe): _____
 Sanitary Facilities (describe): _____
 Sewage odor/presence (describe): _____
 Presence of stormwater pipes or other flow across the beach (describe): _____



Sampling Notes: (Put a mark on the map where you collected the sample)

Date:		Sample Number:	
Additional Comments:			

Example Beach Advisory Sign

CAUTION

Swimming May Cause Illness

WATER CONTACT AND INGESTION OF BEACH WATER MAY BE A HEALTH RISK

DUE TO HIGH LEVELS OF BACTERIA

Swallowing contaminated water may cause nausea, vomiting, diarrhea, and fever, and contact may lead to ear ache or skin rashes.

Wash after contact with water and avoid swallowing it or swimming.

Fish should be rinsed in clean water and cooked before eating.

Water quality samples with elevated enterococci bacteria levels were collected at [Beach Name] on [sampling dates].

The water quality will continue to be monitored.

For more information about the results of sampling, please contact:

[FIRST and LAST NAME] at [PHONE NUMBER] or [EMAIL ADDRESS]

Example DEC Press Release

FOR IMMEDIATE RELEASE: [DATE]

CONTACT: [NAME, TITLE, PHONE, EMAIL]

Elevated Levels of [ENTEROCOCCI/FECAL COLIFORM] Bacteria Found at [BEACH NAME]

Ketchikan, Alaska – ([MONTH DAY, YEAR]) – Recent water quality samples collected at [BEACH NAME] indicate elevated levels of [ENTEROCOCCI/FECAL COLIFORM] bacteria in the water. The Alaska Department of Environmental Conservation (DEC) is collecting the samples this summer to determine if the water is safe for recreation.

Contact with water that has high levels of [ENTEROCOCCI/FECAL COLIFORM] may cause people to have stomach aches, diarrhea, or ear, eye and skin infections.

DEC suggests that beach users take normal precautions to avoid exposure, such as avoiding drinking or swimming in the water; washing after contact with the water, and rinsing fish harvested from the area with clean water. As always, people should cook seafood to a minimum of 145 degrees Fahrenheit internal temperature to destroy pathogens.

[BEACH NAME] is located at the [location description]. Water quality samples were collected [DATE(S)]. DEC continues to monitor water quality. If bacteria levels increase significantly, the [landowner] may post advisory signs at the beach until additional sampling indicates that bacteria numbers have dropped to safe levels.

[ENTEROCOCCI/FECAL COLIFORM] bacteria can come from any warm blooded animal including birds, seals, and humans. [The reason for the currently elevated levels is unknown. List any information know about potential sources, e.g. monitoring from nearby wastewater treatment plants.]

The beach sampling program is being funded and implemented by DEC with cooperation of [GRANTEE AND/OR LANDOWNER]. It is part of a nationwide effort to decrease the incidence of water-borne illness at public beaches under the federal BEACH Act.

For more information about the Alaska beach monitoring program contact the Alaska BEACH Project Manager ([XXXX]) ([907-XXX-XXXX]) or visit the Alaska BEACH Grant Program Website (<https://dec.alaska.gov/applications/eh/EHLlabStatus/MicroReport/Index>)

DEC Approved Labs for Drinking Water

State of Alaska myAlaska My Government Resident Business in Alaska Visiting Alaska State Employees

Alaska Department of Environmental Conservation
Division of Environmental Health

Laboratories Certified to Perform Microbiology Analyses of Drinking Water

For further information about laboratories on this page contact the [Microbiology Certification Officer](#): (907) 375-8209. You may also be interested in: [Labs that are Certified to perform Chemical Analyses of Drinking Water](#).

How to become a Certified Lab in the State of Alaska:

- [Microbiology or Chemistry](#)

Disclaimer

The department in providing these lists does not guarantee the accuracy or validity of the data generated by these laboratories. A laboratory that is certified or approved has established that they have the ability to implement a quality control program in accordance with the appropriate Federal or State regulations or statutes.

Note... Laboratories in **blue** text do not accept samples from the public.

Lab	Method	Analyte
-----	--------	---------

R & M Engineering 355 Carlanna Lake Road Ketchikan, AK 99901-5614 Phone: (907) 225-7917 Fax: (907) 225-3441 Expiration: 06/30/2018 Certification #: AK00911 Status: Provisional	9215 B HPC Pour Plate	Heterotrophic Bacteria
	9222 D Mem. Filtration (mFC)	Fecal Coliform
	MF (mColiBlue 24 MPN)	E. coli
	MF (mColiBlue 24 PA)	E. coli, Total Coliform

Appendix E – Data Graphs

2017 Bacteria Monitoring Results - Knudson Cove

logarithmic scale

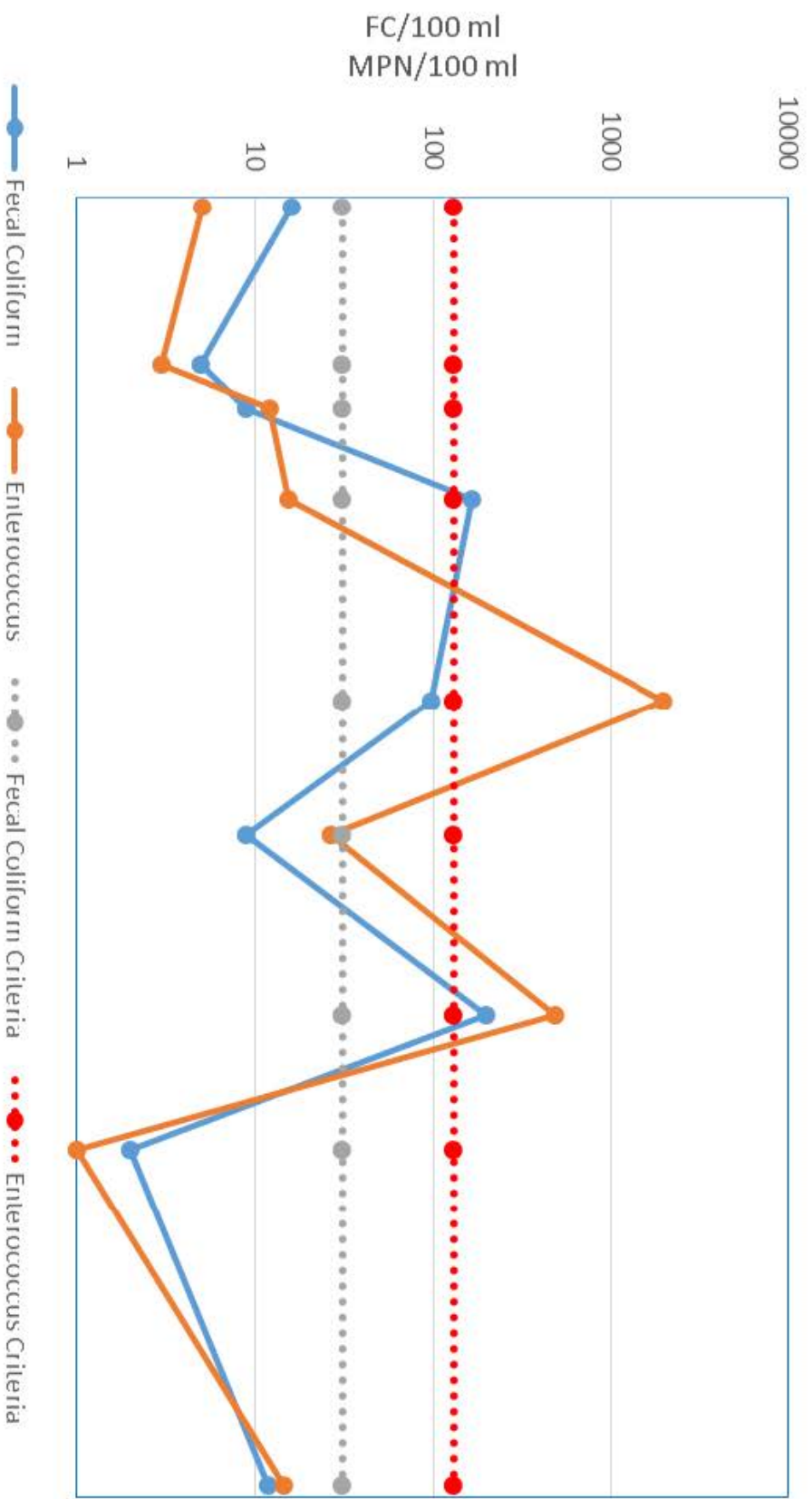

	7/18	7/25	7/27	7/31	8/9	8/15	8/23	8/29	9/13
—●— Fecal Coliform	16	5	9	167	98	9	200	2	12
—●— Enterococcus	5.1	3	12.2	15.6	1986.3	26.9	488.4	1	14.5

2017 Geomean Bacteria Monitoring Results Knudson Cove

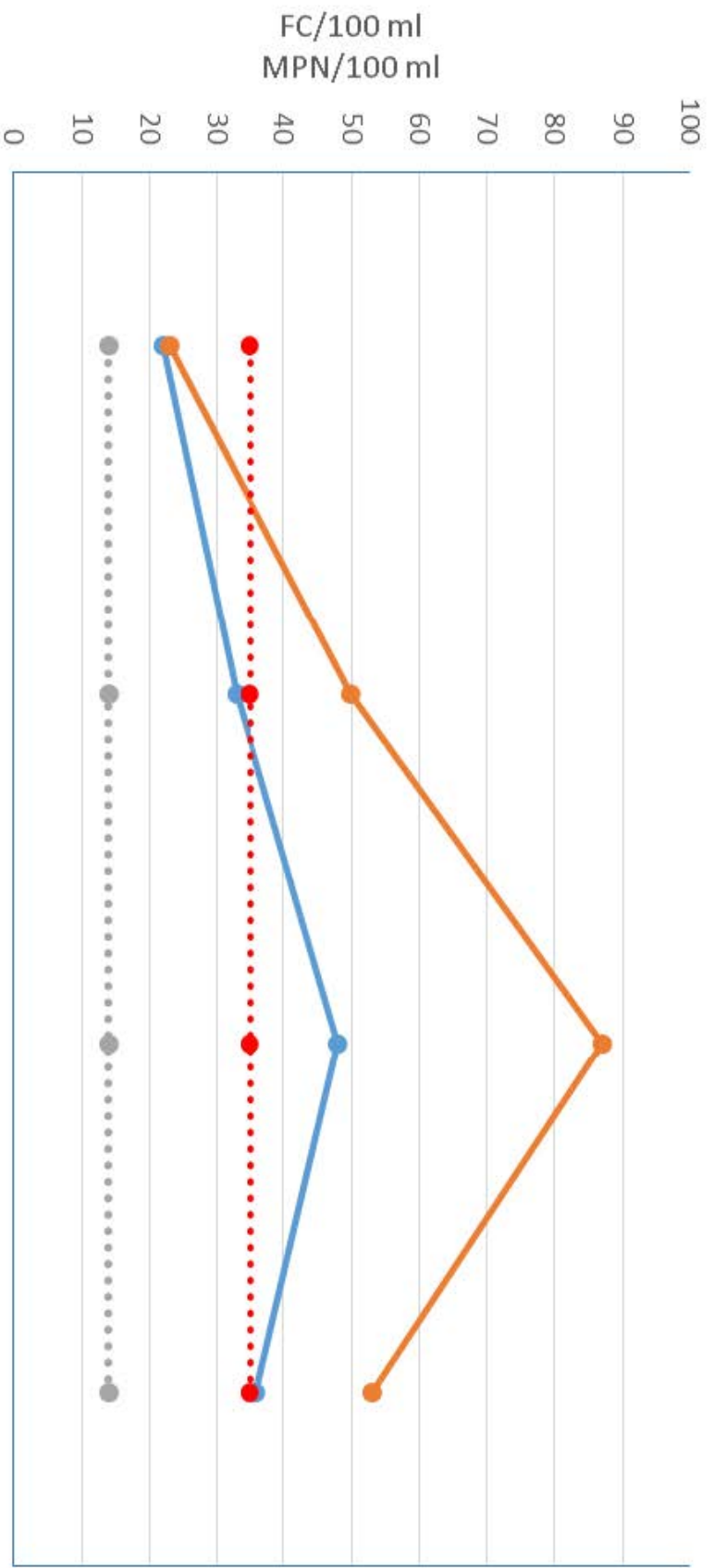

●— Fecal Coliform	●— Enterococcus
-------------------	-----------------

	Jul 18 to Aug 16	Jul 24 to Aug 22	Jul 25 - Aug 24	Jul 31 to Aug 29
Fecal Coliform	22	33	48	36
Enterococcus	23	50	87	53

●— Fecal Coliform
 ●— Enterococcus
 ●●● Fecal Coliform Geomean Criteria
 ●●● Enterococcus Geomean Criteria

2017 Bacteria Monitoring Results - Beacon Hill

logarithmic

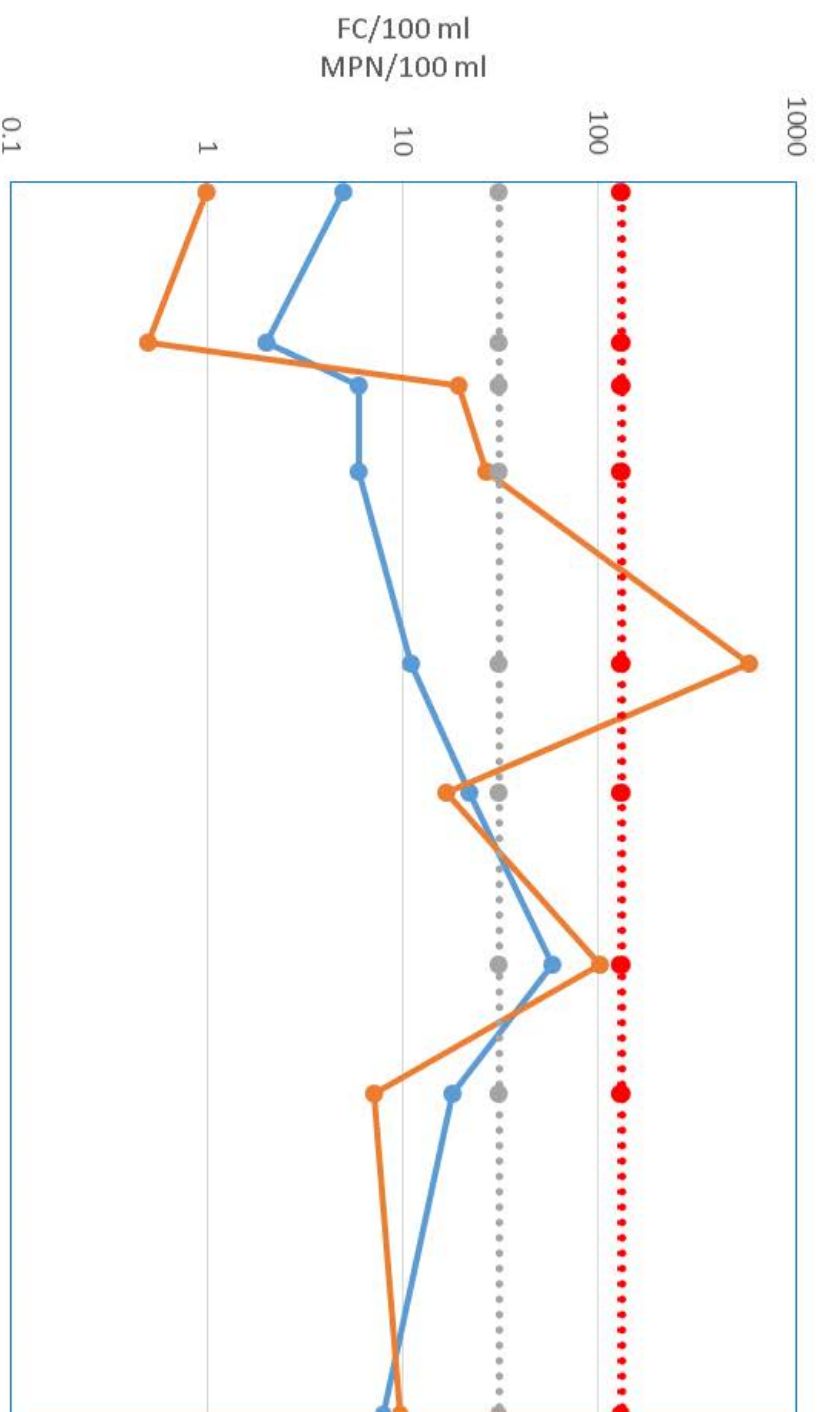

	7/18	7/25	7/27	7/31	8/9	8/15	8/23	8/29	9/13
Fecal Coliform	5	2	6	6	11	22	58	18	8
Enterococcus	1	0.5	19.3	26.6	579.4	16.6	101.7	7.2	9.7

2017 Geomean Bacteria Monitoring Results - Beacon Hill

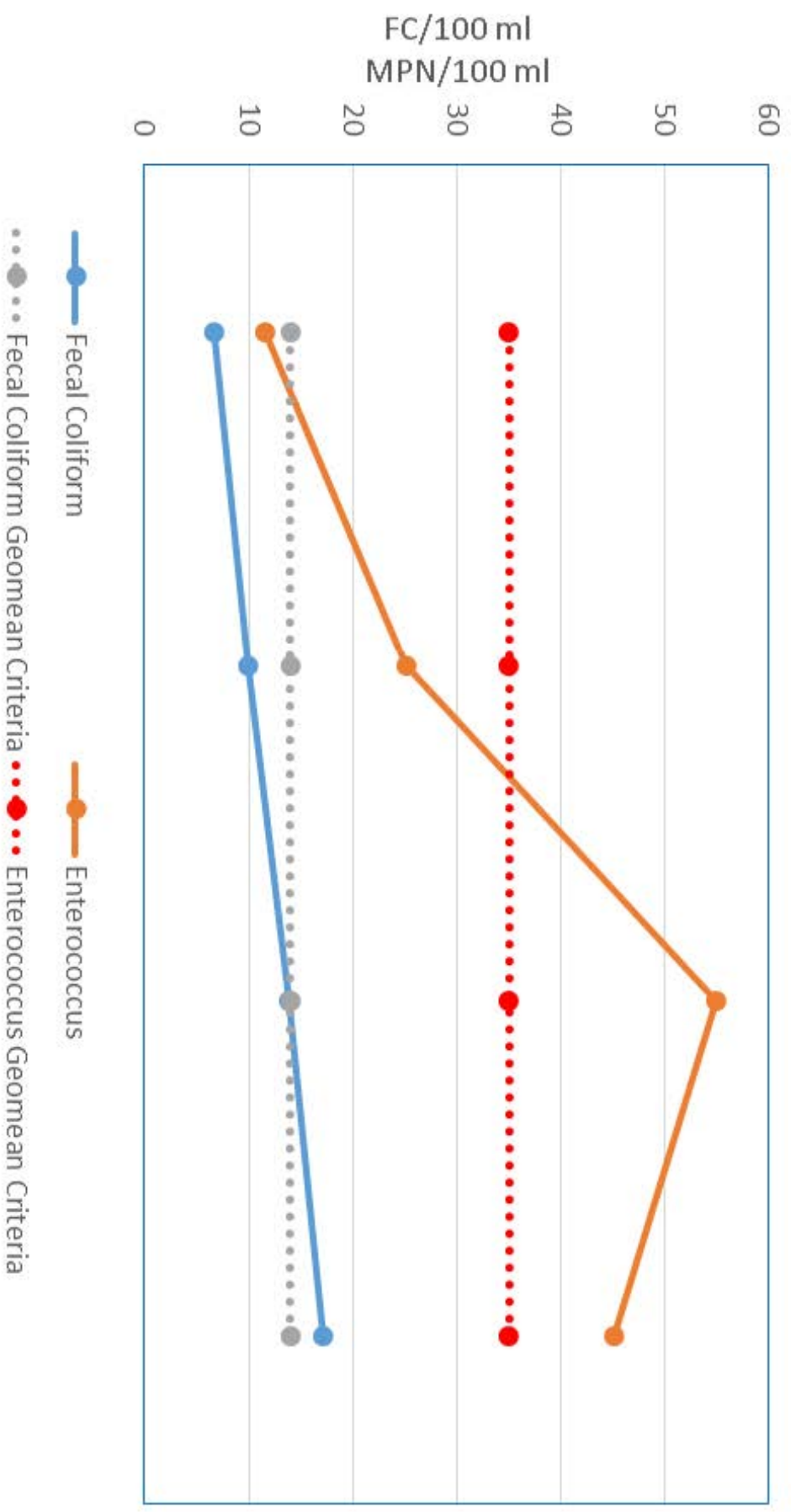

Time Period	Fecal Coliform	Enterococcus
Jul 18 to Aug 16	7	12
Jul 24 to Aug 22	10	25
Jul 26 - Aug 24	14	55
Jul 31 to Aug 29	17	45

2017 Bacteria Monitoring Results - SP Higgins

logarithmic

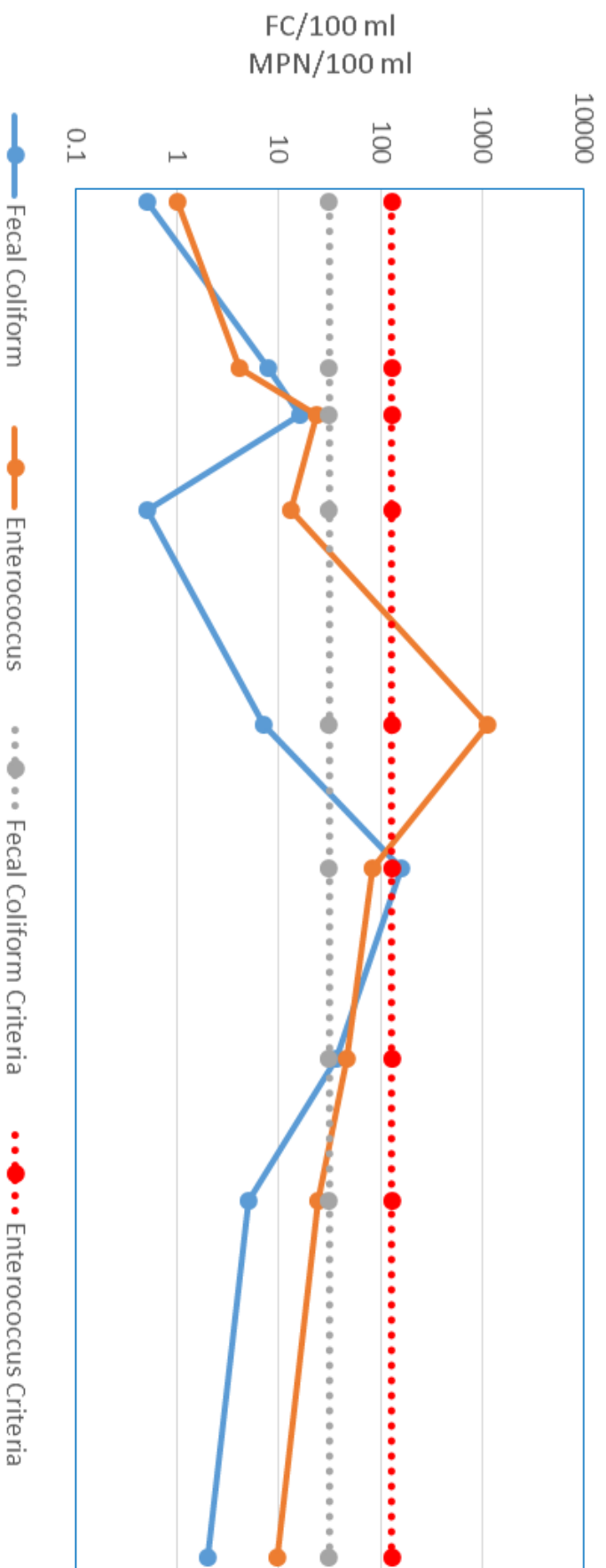

Date	Fecal Coliform	Enterococcus
7/18	0.5	1
7/25	8	4.1
7/27	16	23.8
7/31	0.5	13.1
8/9	7	1119.9
8/15	161	82.3
8/23	37	46.2
8/29	5	24.3
9/13	2	9.5

2017 Geomean Bacteria Monitoring Results SP Higgins

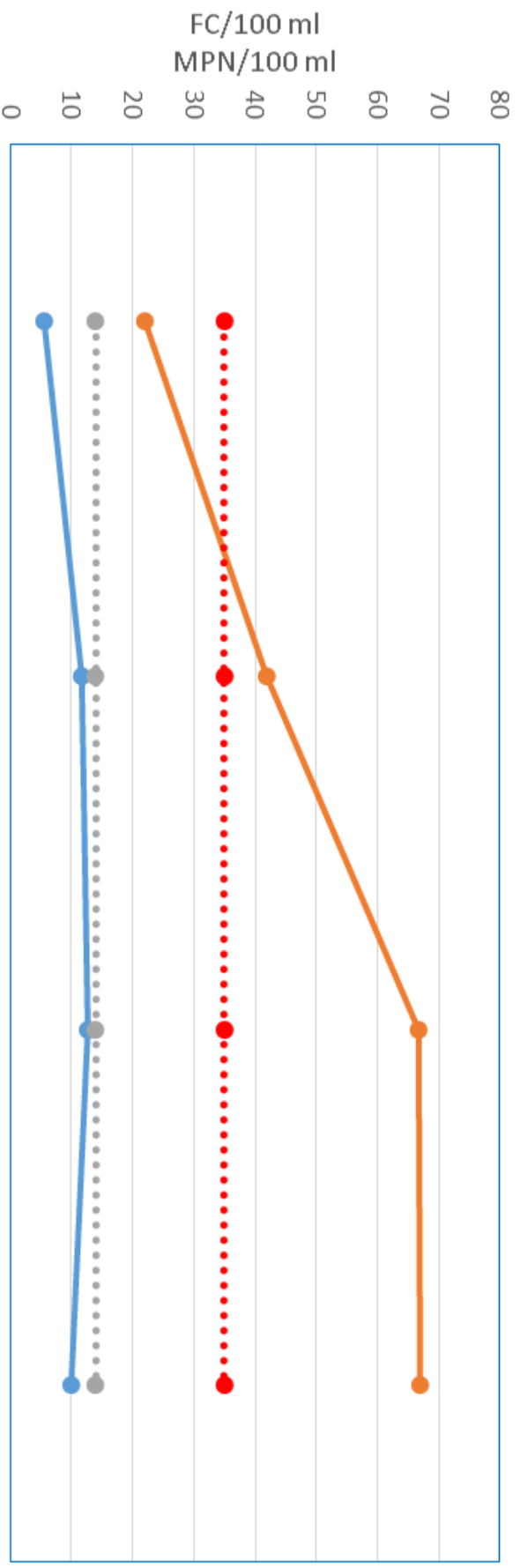

Period	Fecal Coliform	Enterococcus	Geomean Criteria
Jul 18 to Aug 16	6	22	10
Jul 24 to Aug 22	12	42	10
Jul 26 - Aug 24	13	67	10
Jul 31 to Aug 29	10	67	10

2017 Bacteria Monitoring Results - Shull

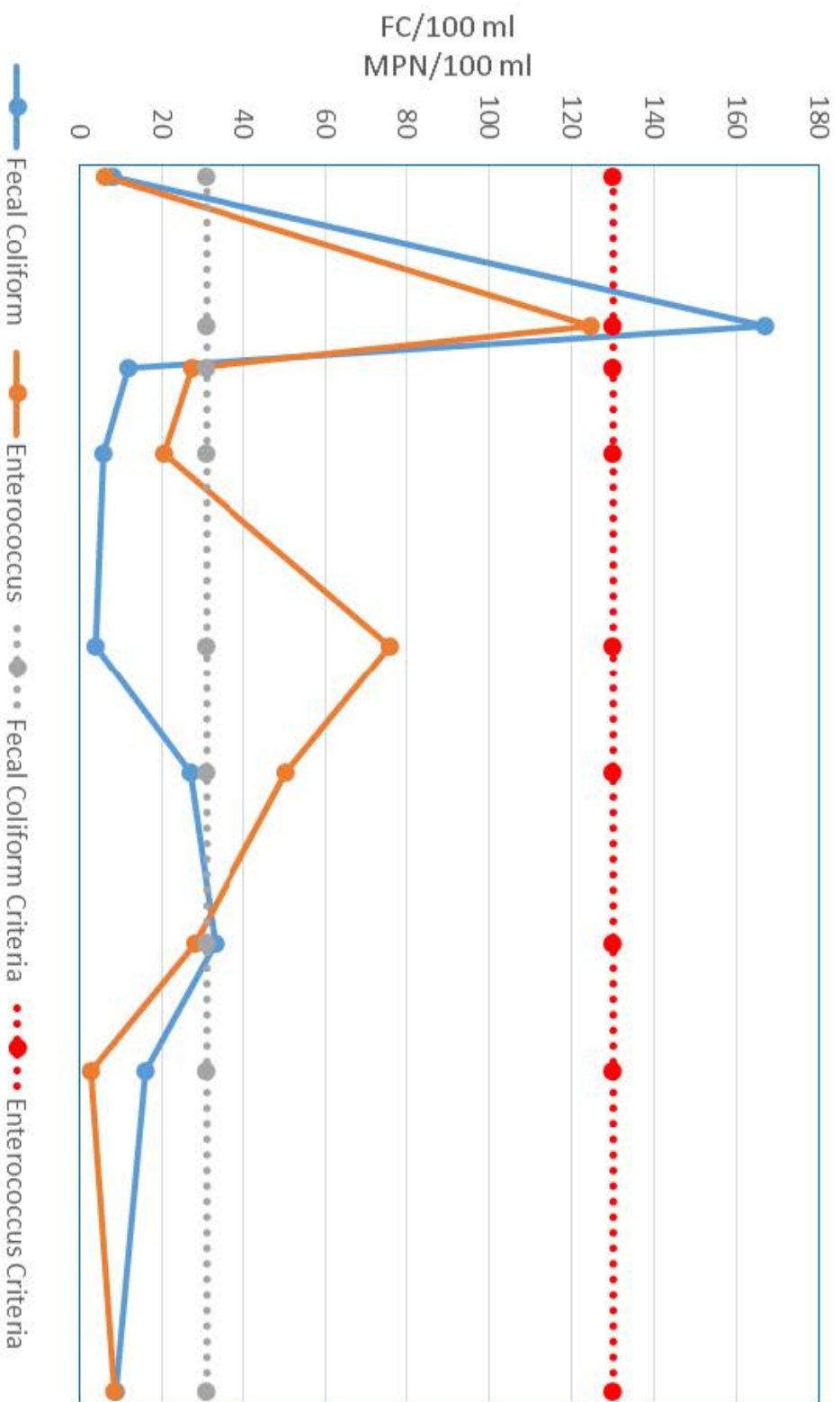

	7/18	7/25	7/27	7/31	8/9	8/15	8/23	8/29	9/13
Fecal Coliform	8	167	12	6	4	27	33	16	9
Enterococcus	6.2	124.6	27.5	20.6	75.9	50.4	28.1	3	8.4

2017 Geomean Bacteria Monitoring Results - Shull

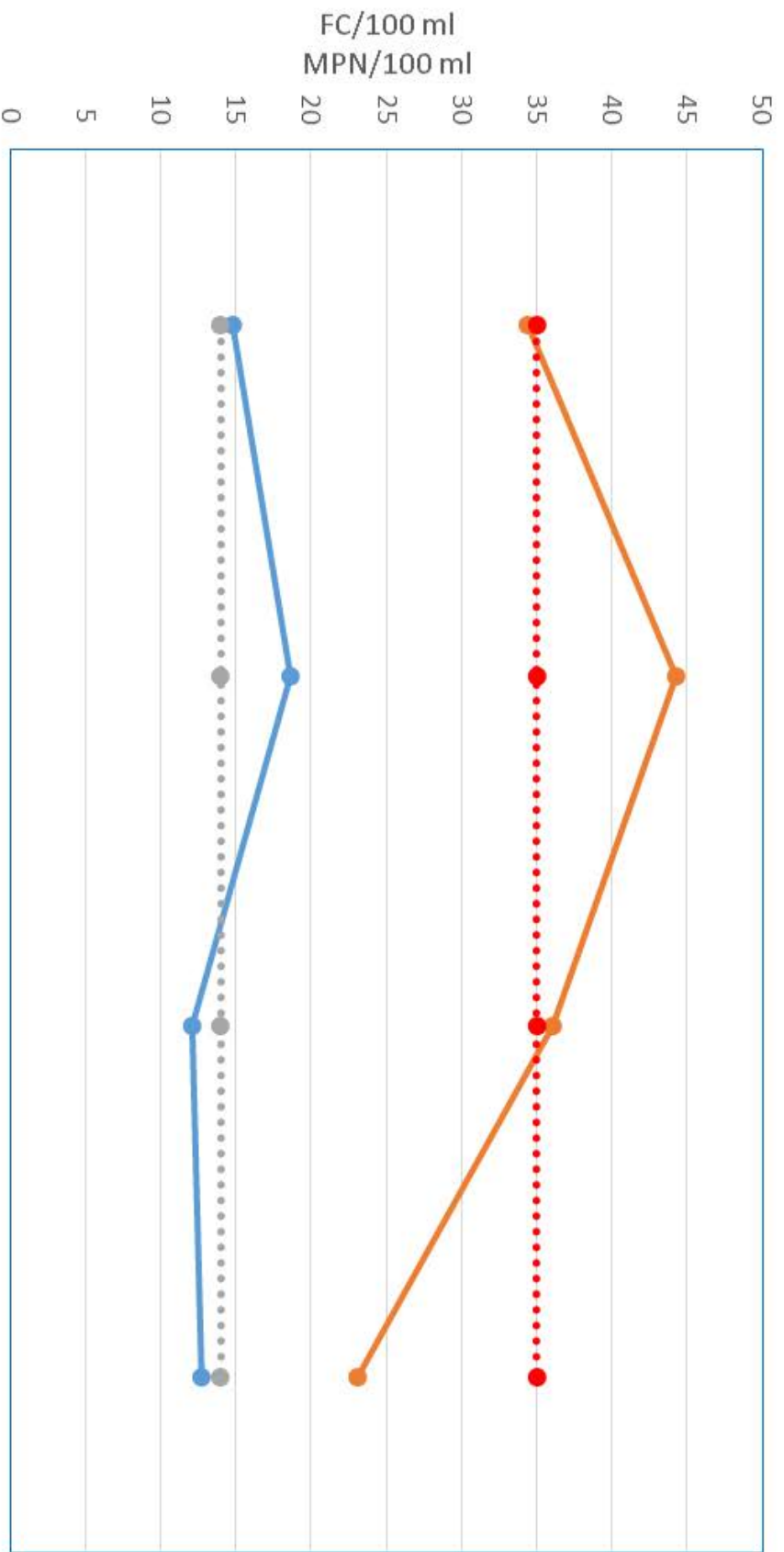

Time Period	Fecal Coliform	Enterococcus
Jul 18 to Aug 16	15	34
Jul 24 to Aug 22	19	44
Jul 26 - Aug 24	12	36
Jul 31 to Aug 29	13	23

2017 Bacteria Monitoring Results - Sunset

Logarithmic

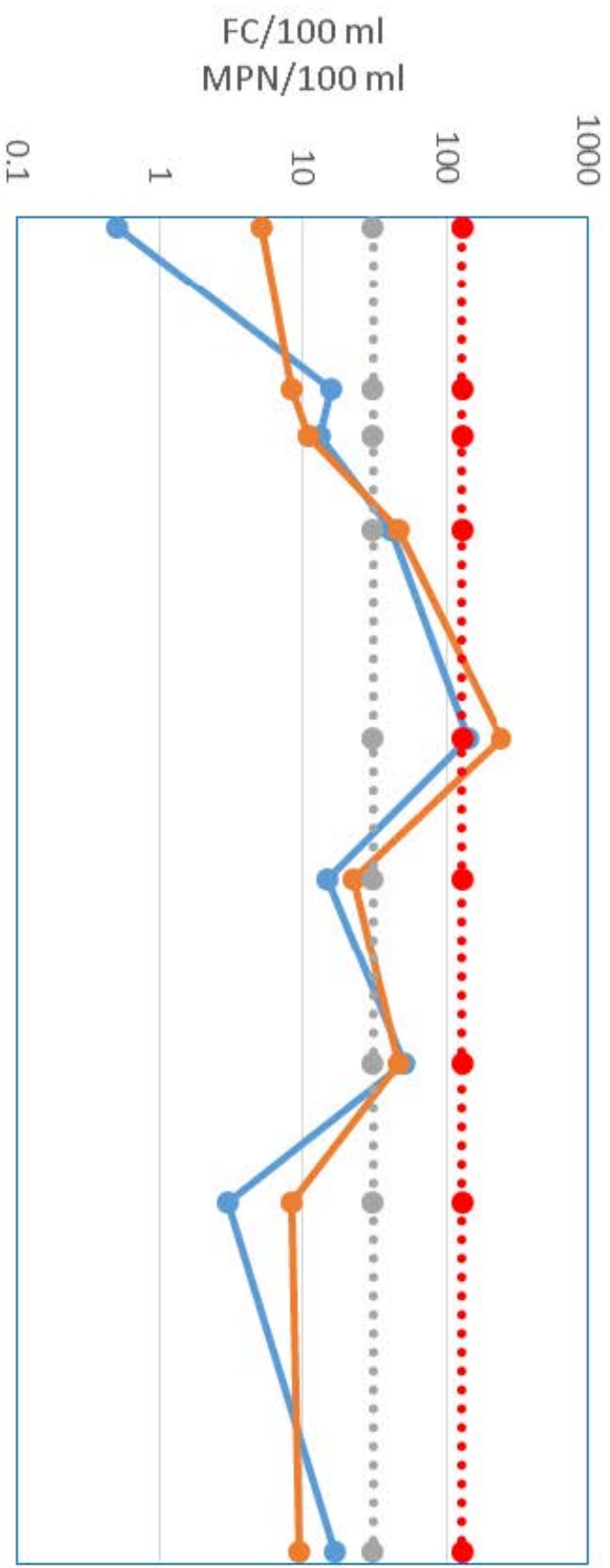

—●— Fecal Coliform —●— Enterococcus
·····●····· Fecal Coliform Criteria ·····●····· Enterococcus Criteria

	7/18	7/25	7/27	7/31	8/9	8/15	8/23	8/29	9/13
—●— Fecal Coliform	0.5	16	13	41	142	15	51	3	17
—●— Enterococcus	5.2	8.5	10.9	46.4	248.1	22.5	47.4	8.5	9.5

2017 Geomean Bacteria Monitoring Results - Sunset

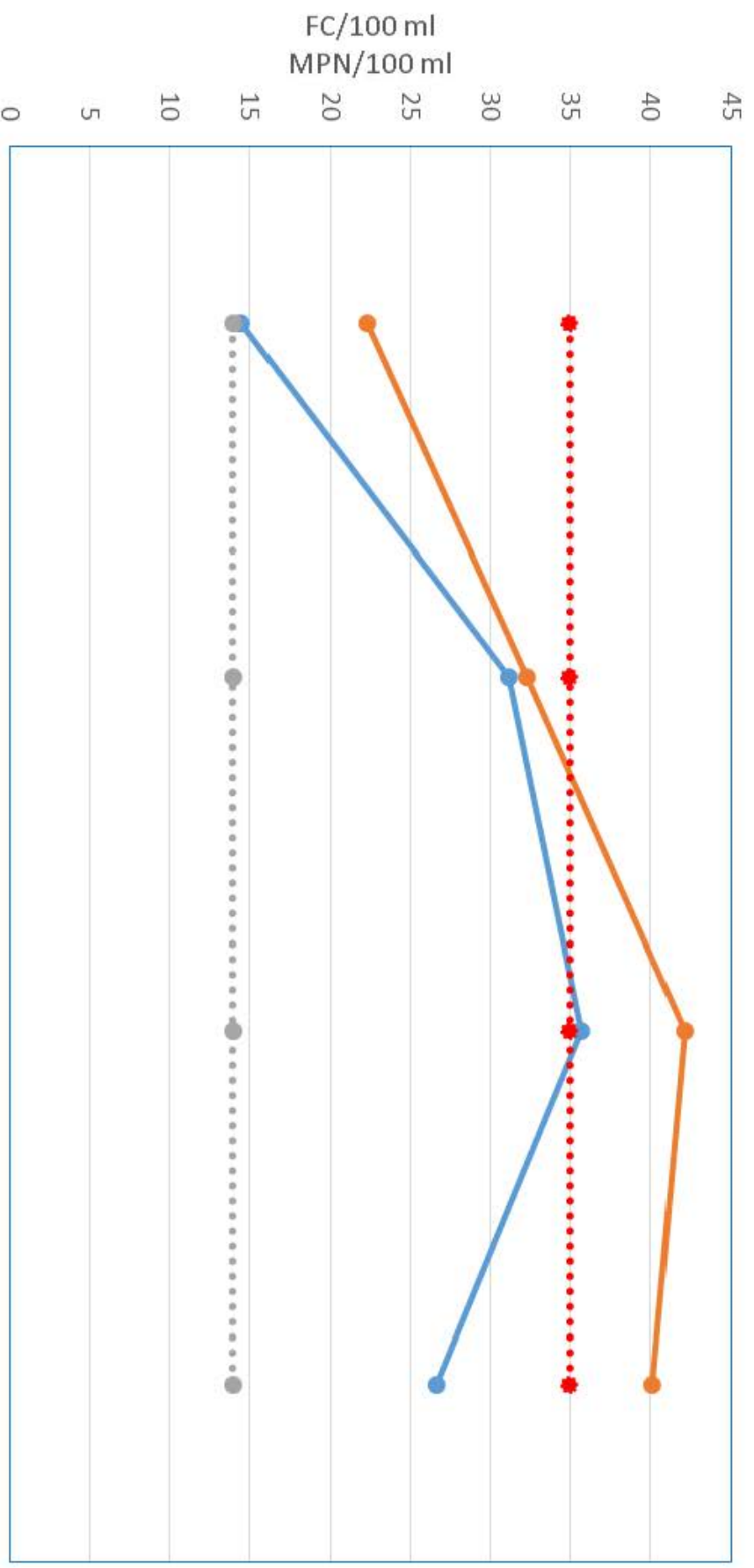

Legend	Jul 18 to Aug 16	Jul 24 to Aug 22	Jul 26 - Aug 24	Jul 31 to Aug 29
Fecal Coliform	14	31	36	27
Enterococcus	22	32	42	40

2017 Bacteria Monitoring Results - S Refuge Cove

logarithmic

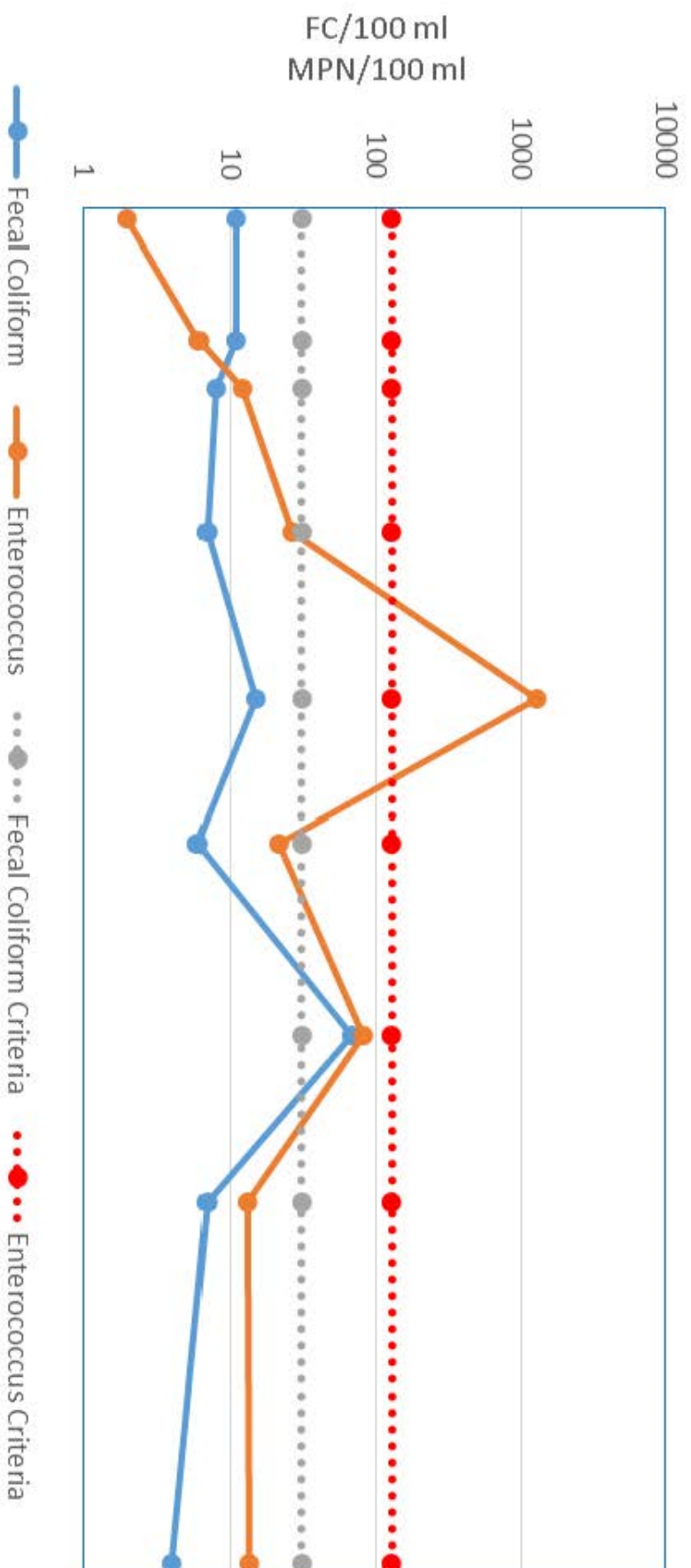

7/19	7/24	7/26	8/1	8/8	8/14	8/22	8/29	9/13
11	11	8	7	15	6	69	7	4
2	6.1	12.1	26.6	1299.7	21.3	81.6	13	13.5

2017 Geomean Bacteria Monitoring Results - S Refuge Cove

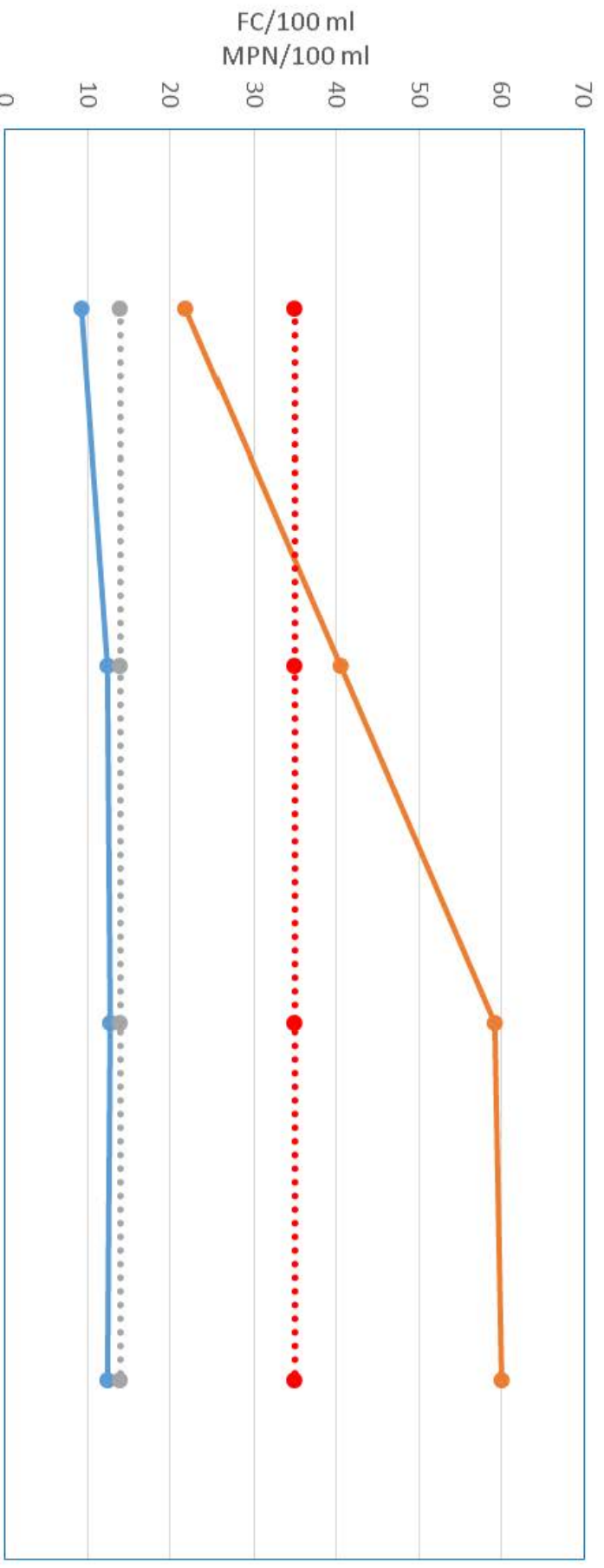

Monitoring Period	Fecal Coliform (FC/100 ml)	Enterococcus (MPN/100 ml)
Jul 18 to Aug 16	9	22
Jul 24 to Aug 22	13	41
Jul 26 - Aug 24	13	59
Jul 31 to Aug 29	12	60

2017 Bacteria Monitoring Results - Thomas Basin

Logarithmic

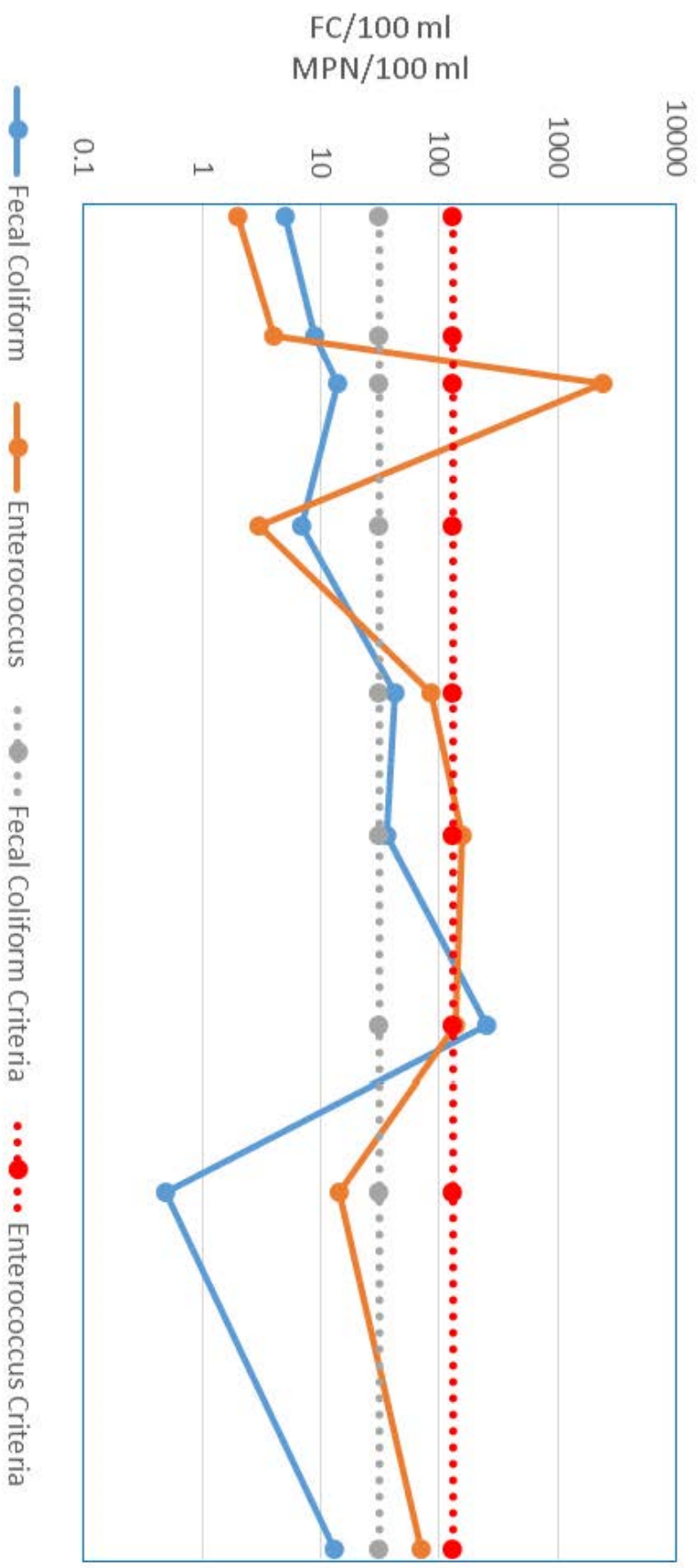

7/19	7/24	7/26	8/1	8/8	8/14	8/22	8/29	9/13
5	9	14	7	42	36	250	0.5	13
2	4.1	2419.6	3	86.2	156.5	137.4	14.5	70.3

2017 Geomean Bacteria Monitoring Results - Thomas Basin

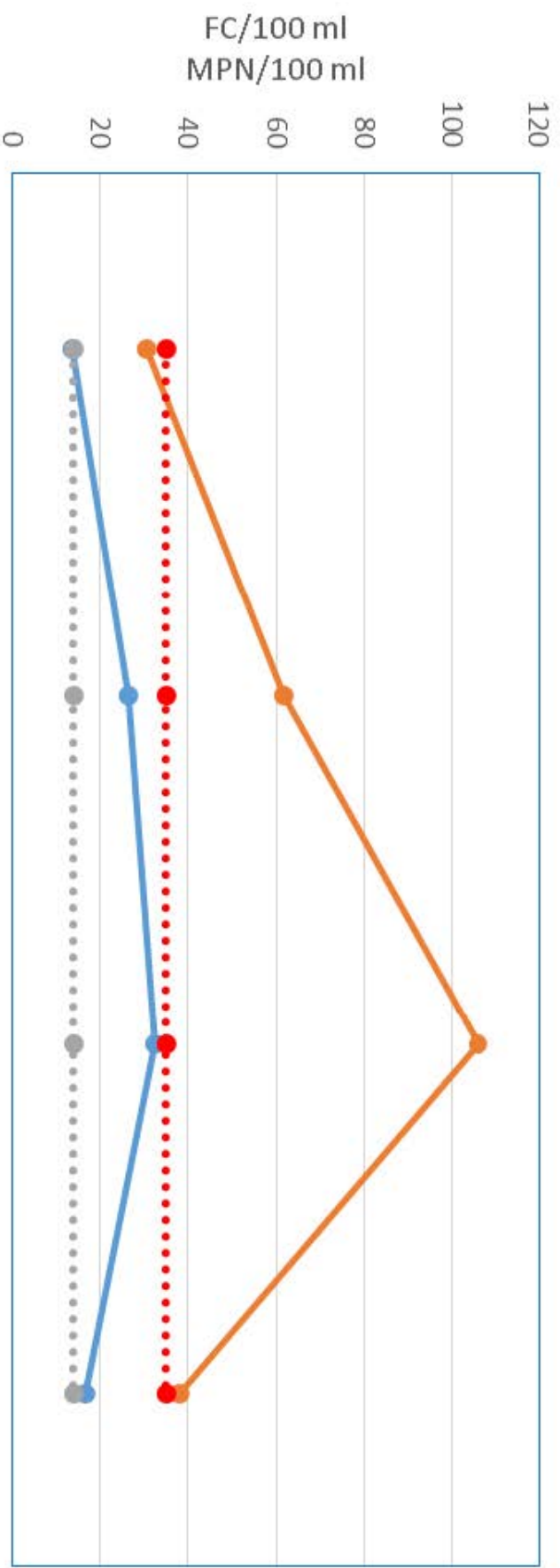

Time Period	Fecal Coliform	Enterococcus
Jul 18 to Aug 16	14	30
Jul 24 to Aug 22	26	62
Jul 26 - Aug 24	33	106
Jul 31 to Aug 29	17	38

2017 Bacteria Monitoring Results - Seaport

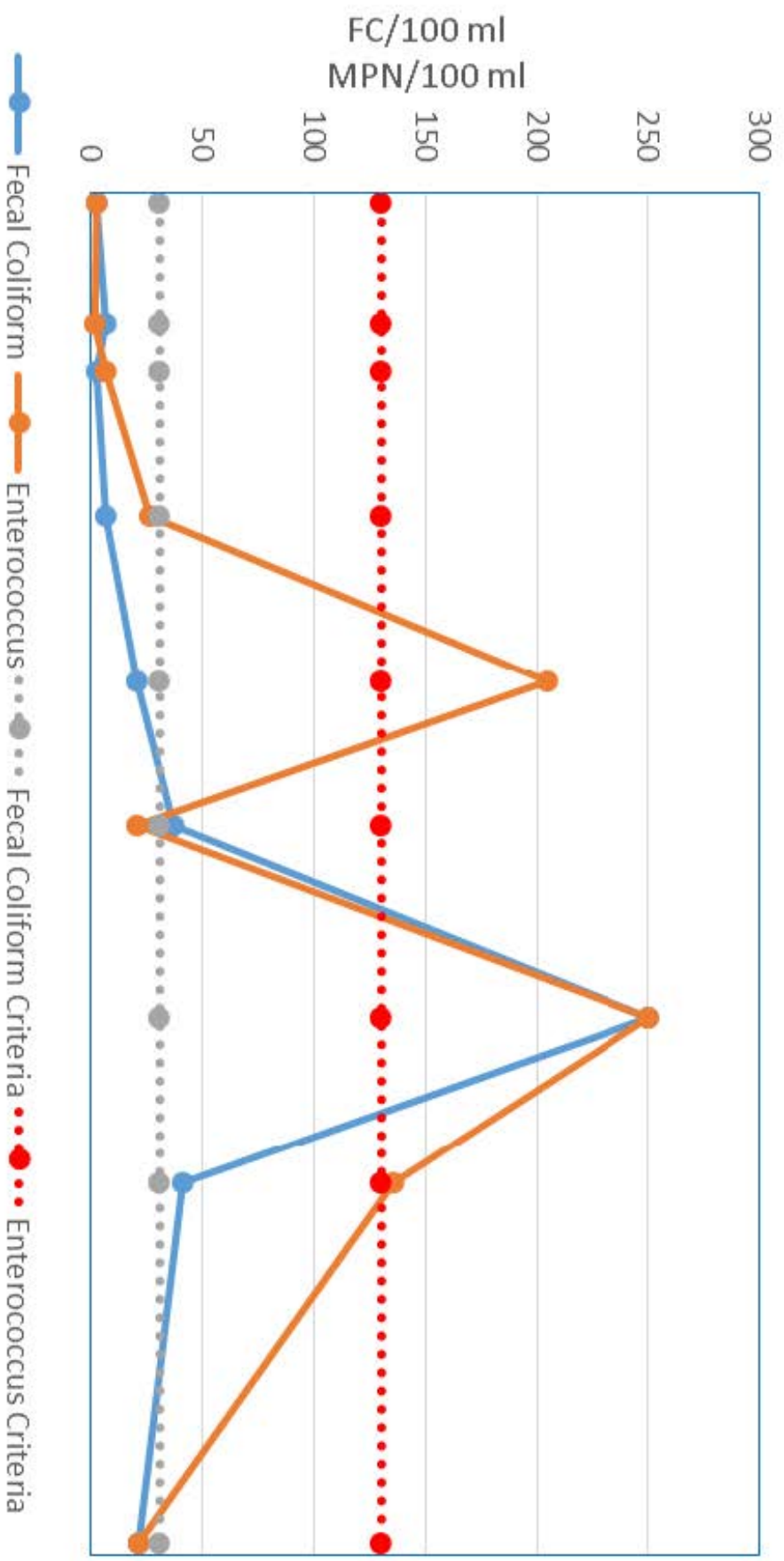

Date	Fecal Coliform	Enterococcus
19-Jul	3	3.1
24-Jul	7	2
26-Jul	3	7.3
1-Aug	7	26.6
8-Aug	21	204.6
14-Aug	37	21.1
22-Aug	250	250
29-Aug	41	135.4
13-Sep	22	21.3

2017 Geomean Bacteria Monitoring Results - Seaport

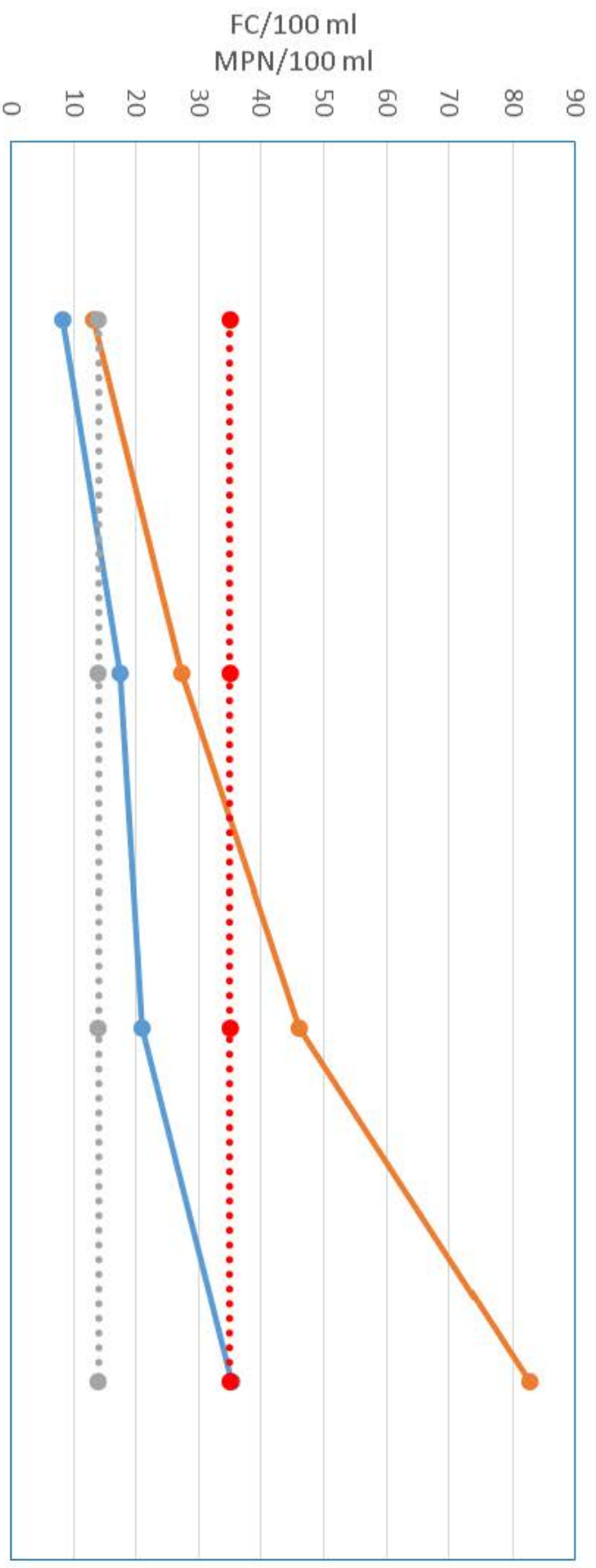

Monitoring Period	Fecal Coliform	Enterococcus
Jul 18 to Aug 16	8	13
Jul 24 to Aug 22	17	27
Jul 26 - Aug 24	21	46
Jul 31 to Aug 29	35	83

2017 Bacteria Monitoring Results - Rotary

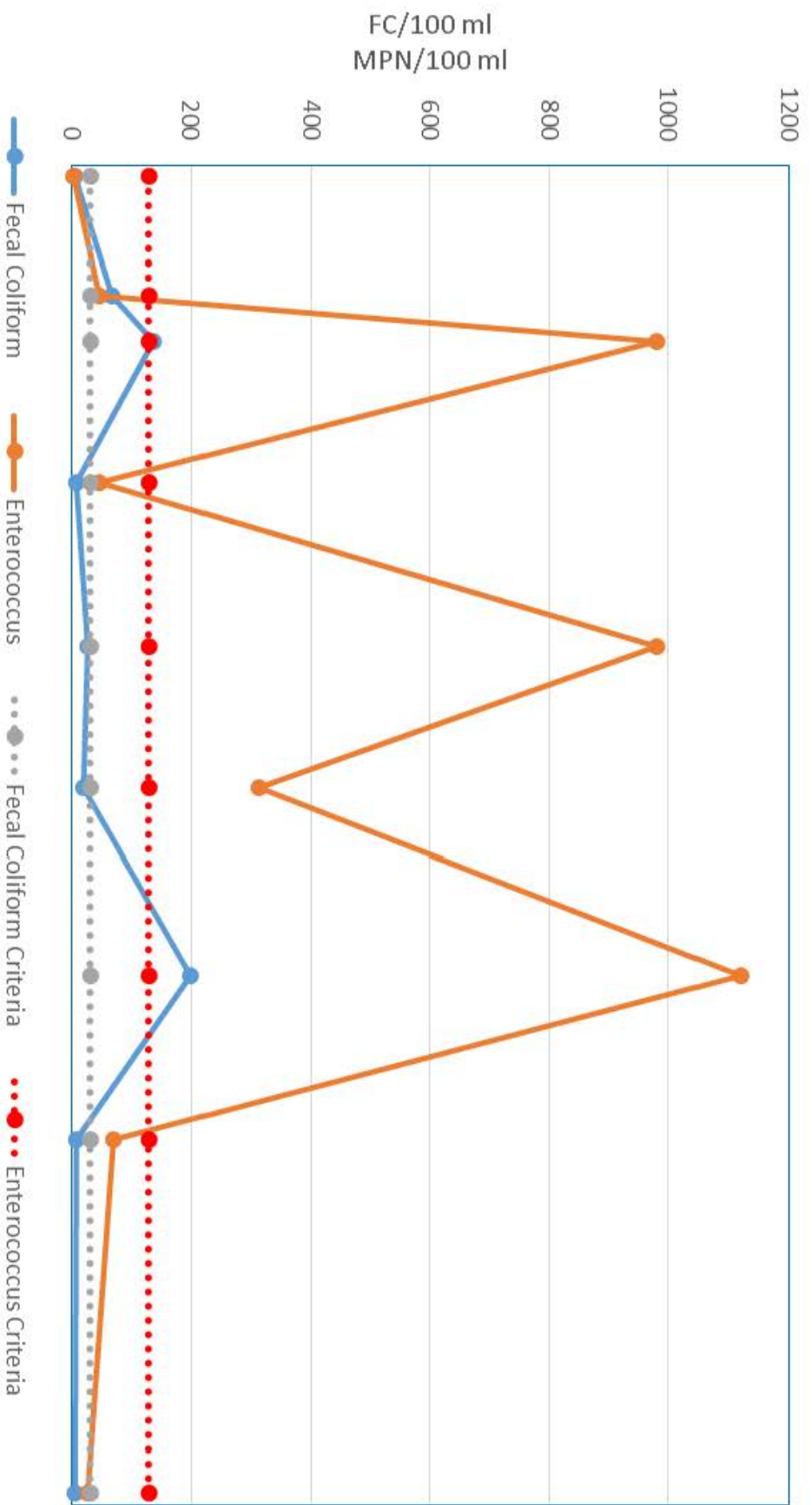

Date	Fecal Coliform	Enterococcus
19-Jul	6	3
24-Jul	68	45.7
26-Jul	137	980.4
1-Aug	9	47.4
8-Aug	27	980.4
14-Aug	21	313
22-Aug	200	1119.9
29-Aug	9	69.3
13-Sep	6	26.2

2017 Geomean Bacteria Monitoring Results - Rotary

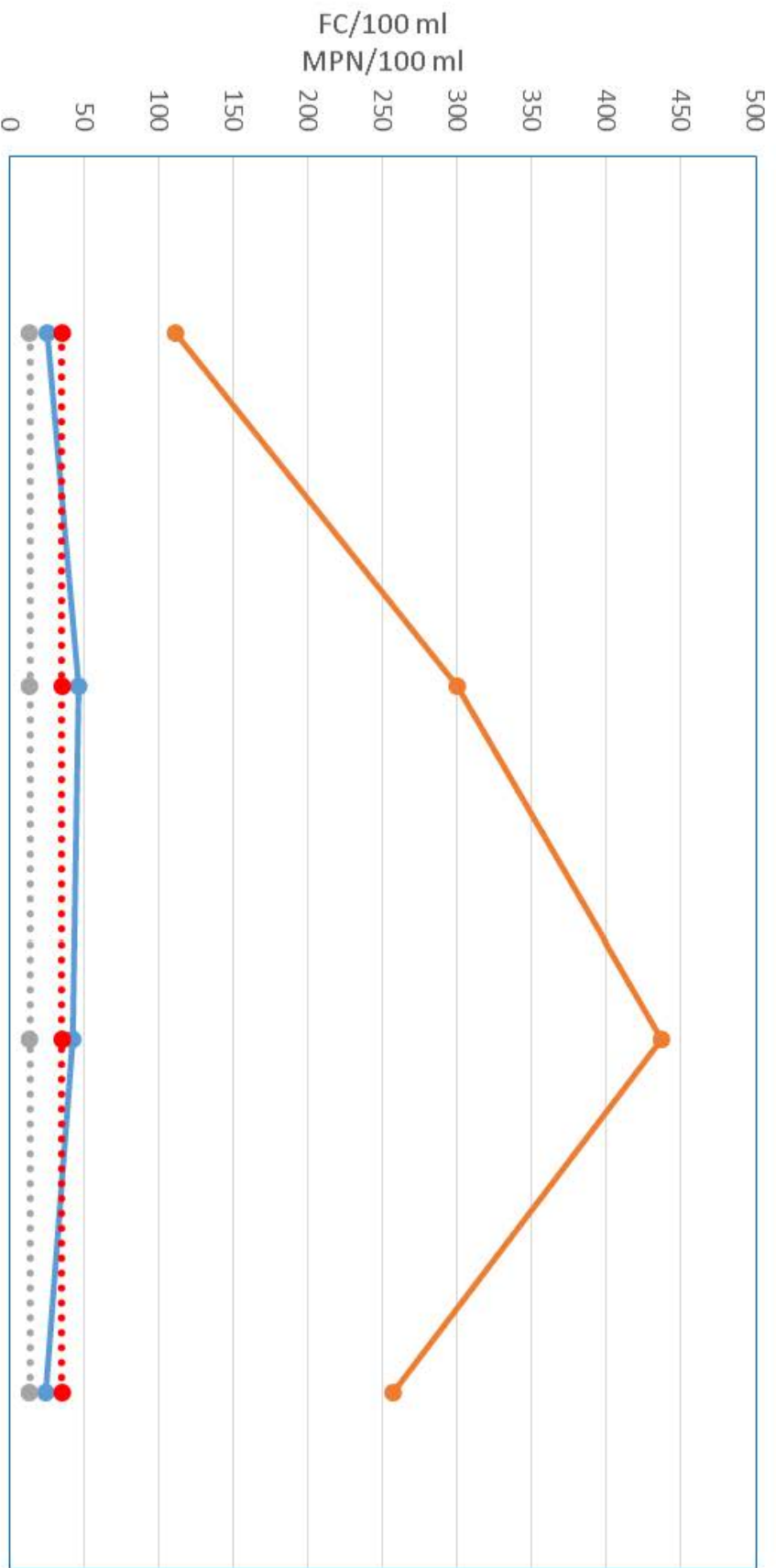

Monitoring Period	Fecal Coliform (FC/100 ml)	Enterococcus (MPN/100 ml)
Jul 18 to Aug 16	26	112
Jul 24 to Aug 22	46	300
Jul 26 - Aug 24	43	437
Jul 31 to Aug 29	25	257

This page intentionally left blank.

Appendix F – Press Releases

Larry Hartig
Commissioner

P.O. Box 111800
Juneau, AK 99811-1800
www.dec.alaska.gov



Candice Bressler
Public Information Officer
907.465.5009

candice.bressler@alaska.gov

Press Release

COMMISSIONER'S OFFICE

FOR IMMEDIATE RELEASE — August 11, 2017

CONTACT: Nancy Sonafrank, Division of Water, (907) 451-2726, nancy.sonafrank@alaska.gov

DEC Finds Elevated Bacteria Levels on Coastal Areas in Ketchikan

Enterococci bacteria may indicate a health risk

(KETCHIKAN, AK) — The Alaska Department of Environmental Conservation (DEC) recently collected water quality samples along coastal beach areas in Ketchikan, Alaska. These samples indicated elevated levels of enterococci bacteria in the marine water at the following locations:

- Beacon Hill (off of North Point Higgins Road)
- Knudson Cove Marina (north of Ketchikan)
- Refuge Cove Beach (south end of Refuge Cove Beach State Park)
- Rotary Beach also known as Bugges Beach (located approximately 3.4 miles south of town on South Tongass Highway)
- Seaport Beach (near Saxman)
- South Point Higgins Beach (12 miles north of Ketchikan)
- Sunset Beach (south end of Mud Bay)

Contact with water impacted by enterococci bacteria may cause stomach aches, diarrhea, or ear, eye, and skin infections. DEC recommends beach users take normal precautions to avoid exposure, such as avoiding swimming in the water, washing after contact with the water, and rinsing fish with clean water after they have been harvested from the area. As always, people should cook seafood to a minimum internal temperature of 145 degrees Fahrenheit to destroy pathogens.

Water quality samples collected on August 8 and 9 contained levels well above Alaska's enterococci bacteria limit. Until sample results meet water quality standards and DEC lifts this advisory, people should take precautionary measures when recreating. DEC plans to continue monitoring and sampling until results are within the criteria. The next sampling will occur next week.

The beach sampling program is being funded and implemented by DEC. It is part of a nationwide effort to decrease the incidence of water-borne illness at public beaches under the federal Beaches Environmental Assessment and Coastal Health (BEACH) Act.

For more information about the Alaska beach monitoring program, visit the Alaska BEACH Grant Program Website: <http://www.dec.state.ak.us/water/wqsar/wqs/beachprogram.htm>.

###



State of Alaska
Department of Environmental Conservation



Larry Hartig
Commissioner

Candice Bressler 907.465.5009
Public Information Officer candice.bressler@alaska.gov

FOR IMMEDIATE RELEASE — August 17, 2017

CONTACT: Nancy Sonafrank, Division of Water, (907) 451-2726, nancy.sonafrank@alaska.gov

DEC Reports Bacteria Levels on Coastal Areas in Ketchikan Have Decreased

(KETCHIKAN, AK) — The Alaska Department of Environmental Conservation (DEC) has confirmed enterococci bacteria levels have decreased, but are still above water quality criteria at two coastal areas in Ketchikan.

DEC recently collected water quality samples at nine coastal areas, including: South Refuge Cove Beach, Seaport Beach, Rotary Beach also known as Bugges Beach, Thomas Basin, Beacon Hill, Knudson Cove Marina, South Point Higgins Beach, Sunset Beach, and Shull Beach. Earlier sampling showed seven of these coastal areas as having bacterial levels above what is considered a safe level.

The following locations still exceed water quality criteria:

- Rotary Beach also known as Bugges Beach (located approximately 3.4 miles south of town on South Tongass Highway)
- Thomas Basin (at Creek Street Bridge)

All seven other locations meet water quality criteria. DEC plans to continue weekly sampling until results are within the criteria. Additional sampling at all nine coastal areas is planned for the week of August 21.

Contact with water impacted by enterococci bacteria may cause stomach aches, diarrhea, or ear, eye, and skin infections. Continued precautionary measures are advised. DEC recommends beach users avoid exposure, such as avoiding swimming in the water, washing after contact with the water, and rinsing fish with clean water after they have been harvested from the area. As always, people should cook seafood to a minimum internal temperature of 145 degrees Fahrenheit to destroy pathogens.

The beach sampling program is being funded and implemented by DEC. It is part of a nationwide effort to decrease the incidence of water-borne illness at public beaches under the federal Beaches Environmental Assessment and Coastal Health (BEACH) Act.

For more information about the Alaska beach monitoring program, visit the Alaska BEACH Grant Program Website: <http://www.dec.state.ak.us/water/wqsar/wqs/beachprogram.htm>.

###



State of Alaska
Department of Environmental Conservation



Larry Hartig
Commissioner

Candice Bressler 907.465.5009
Public Information Officer candice.bressler@alaska.gov

FOR IMMEDIATE RELEASE — August 25, 2017

CONTACT: Nancy Sonafrank, Division of Water, (907) 451-2726, nancy.sonafrank@alaska.gov

DEC Reports Elevated Bacteria Levels at Four Coastal Areas in Ketchikan

(KETCHIKAN, AK) — The Alaska Department of Environmental Conservation (DEC) has confirmed enterococci bacteria levels remain above criteria at four coastal areas in Ketchikan.

Since July 18, DEC has been collecting water quality samples at nine coastal areas, including: South Refuge Cove Beach, Seaport Beach, Rotary Park Beach also known as Bugges Beach, Thomas Basin, Beacon Hill, Knudson Cove, South Point Higgins Beach, Sunset Beach, and Shull Beach.

Samples collected at the following locations on August 22 and 23 exceed water quality criteria:

- Rotary Park Beach also known as Bugges Beach (located approximately 3.4 miles south of town on South Tongass Highway)
- Thomas Basin (at Creek Street Bridge)
- Seaport Beach (near Saxman)
- Knudson Cove (north of Ketchikan)

All five other tested locations meet water quality criteria. DEC plans to continue weekly sampling. Advisories for the affected beaches will remain in effect until bacteria levels for all beaches are within acceptable levels.

Contact with water impacted by fecal bacteria may cause stomach aches, diarrhea, or ear, eye, and skin infections. The beach sampling program uses enterococci as an indicator for fecal bacteria in marine waters. Continued precautionary measures are advised. DEC recommends beach users avoid exposure, such as avoiding swimming in the water, washing after contact with the water, and rinsing fish with clean water after they have been harvested from the area. As always, people should cook seafood to a minimum internal temperature of 145 degrees Fahrenheit to destroy pathogens.

Enterococci bacteria can come from any warm blooded animal, including birds, seals, and dogs, as well as humans. Potential sources of this bacteria in Ketchikan may include wildlife and pet

feces, human waste from private or municipal treatment systems, sewer line leakage, and/or boats in harbor areas. Additional DNA marker testing is being conducted to help determine the bacteria source(s). Results are anticipated in mid-September.

The beach sampling program is being implemented by DEC. It is part of a nationwide effort to decrease the incidence of water-borne illness at public beaches under the federal Beaches Environmental Assessment and Coastal Health (BEACH) Act, funded by an EPA BEACH grant.

For more information about the Alaska beach monitoring program, visit the Alaska BEACH Grant Program Website: <http://dec.state.ak.us/water/wqsar/wqs/beachprogram.htm>.

###

State of Alaska
Department of Environmental Conservation



Larry Hartig
Commissioner

Candice Barber 907.465.5009
Public Information Officer candice.barber@alaska.gov

FOR IMMEDIATE RELEASE — September 18, 2017

CONTACT: Nancy Sonafrank, Division of Water, (907) 451-2726, nancy.sonafrank@alaska.gov

DEC Reports No Elevated Bacteria Levels at Coastal Areas in Ketchikan

(KETCHIKAN, AK) — The Alaska Department of Environmental Conservation (DEC) has confirmed enterococci bacteria levels have tested below water quality criteria for all nine coastal areas in Ketchikan.

From July 18 to September 13, DEC collected water quality samples at nine coastal areas in Ketchikan including: South Refuge Cove Beach, Seaport Beach, Rotary Park Beach also known as Bugges Beach, Thomas Basin, Beacon Hill, Knudson Cove, South Point Higgins Beach, Sunset Beach, and Shull Beach. The latest tests on September 13 show all locations meeting the water quality standards for enterococci. Therefore, DEC is withdrawing the recreational beach advisory issued in August. DEC will suspend bacteria monitoring in the Ketchikan coastal areas until the 2018 summer recreation season.

Enterococci bacteria can come from any warm blooded animal, including birds, seals, and dogs, as well as humans. Potential sources of this bacteria in Ketchikan may include wildlife and pet feces, human waste from private and municipal treatment systems, sewer line leakage, and/or boats in harbor areas. Additional DNA marker testing was conducted and is currently being evaluated to help determine whether the bacteria source(s) are human, animals, or birds. The DNA testing for all nine locations indicated bacteria were present from human sources, although animal and bird sources were also identified at some locations. A project report is anticipated in November and will be posted on the DEC Alaska BEACH webpage at <http://dec.alaska.gov/water/wqsar/wqs/beachprogram.htm>.

The beach sampling program is being implemented by DEC. It is part of a nationwide effort to decrease the incidence of water-borne illness at public beaches under the federal Beaches Environmental Assessment and Coastal Health (BEACH) Act, funded by an EPA BEACH grant. Since 2002, the Alaska's BEACH Program has been monitoring recreational beaches throughout the state, including other communities in southeast Alaska: Douglas Island, Haines, Juneau, Petersburg, and Wrangell. Sample results have not shown persistent elevated levels of bacteria in these communities.

For more information about the Alaska beach monitoring program, visit the Alaska BEACH Grant Program Website: <http://dec.state.ak.us/water/wqsar/wqs/beachprogram.htm>.

###